

siegmund

Dach für Laserschweißzelle · Roof for laser welding cell

A: 2400x2400 / B: 3600x3600 / C: 4800x3600

Montageanleitung · Assembly instructions

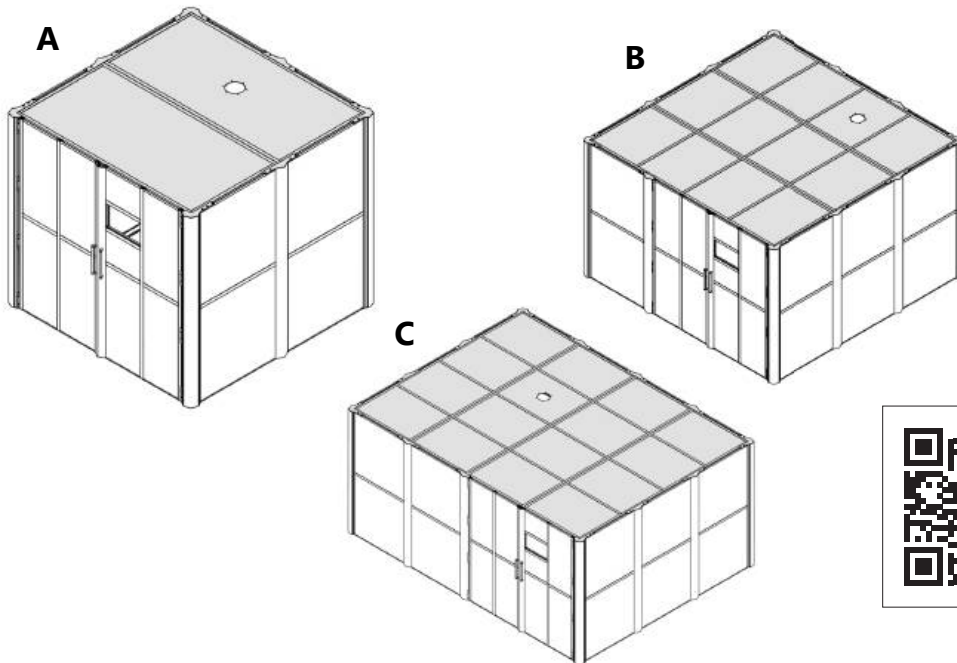

Mit Schraubenschlüssel festziehen · Tighten by wrench · Затягнете с гаечен ключ · Utáhněte pomocí klíče · Stram med nøgle · Pingutata vōtmeġa · Apertado con llave · Kiristä jakoavaimella · Serrer avec une clé · Σφίξιμο με κλειδί · Zategnuti ključem · Kulccsal feszítse meg · Serrare con chiave · Priveržkite veržliarakčiu · Aandraaien met een sleutel · Stram til med fastnøkkel · Przykręć kluczem · Aperto com chave · Strângeți cu o cheie · Zategnuti ključem · Затянуть ключом · Spänn åt med skiftnyckel · Priviti s ključem · Utiahnite klúčom · Anahtarla sıkmak



















Handfest - Bitte nicht festziehen · Hand-screwed - please do not tighten · Ръчно завинтване - моля, не затягайте с помощен инструмент · Ručně zašroubováno - prosím nedotahujte · Håndskruet - stram venligst ikke · Käsitsi kinnitatav - ärge kinnitage jõuga · Enroscado a mano - no apretar · Käsikireys - ei saa kiristää työkalulla · Serré à la main - Ne pas serrer · Βιδώστε με το χέρι - παρακαλούμε μην σφίγγετε · Ručno zategnuti - ne prejako · Kézi rögzítés - ne húzza meg erősen · Avvitare a mano - non serrare forte · Rankinis prisukamas - prašome neužveržkite · Aandraaien met de hand - niet te vast aandraaien · Hånd skrudd, ikke stram til · Przykręć ręcznie - proszę nie dokręcać · Aperto manual - por favor não force o aperto · Înșurubat manual - vă rugăm să nu strângeți · Ručno zavrnuti - molimo vas da ne pretežete · Завинчивать вручную - не затягивать · Handskruvad - spänn inte åt · Ročno priviti - prosim ne zategujte · Ručné naskrutkovanie - prosím, neúfahujte silou · El vidalı - lütfen sıkmayın





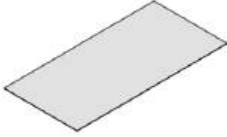
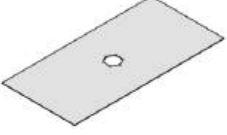
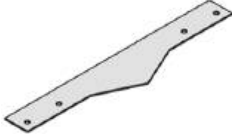
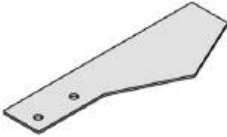
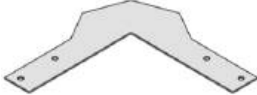
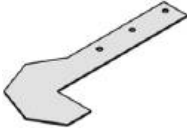
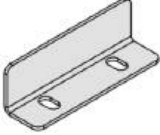
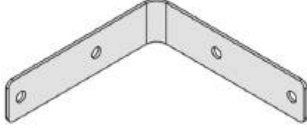

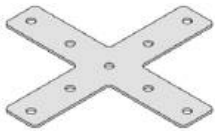
Bernd Siegmund GmbH

Landsberger Straße 180 | 86507 Oberottmarshausen | Germany (Bavaria) | Phone +49 8203 9607-0 | Fax +49 8203 9607-33
info@siegmund.com | www.siegmund.com

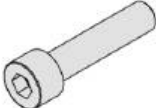
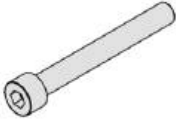
All texts, pictures and design elements are copyrighted by the Bernd Siegmund GmbH. No part of this flyer may be edited analogously or digital or in another mode, may be multiplied or published out of the flyer without written approval of the legal owner. Offences are prosecuted.

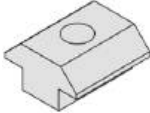
ART.	OVERVIEW	NAME	QTY	ERP
T1		C-Profil / C-profile 1030	C: 9	00005247
T2		C-Profil / C-profile 1118	A: 4 B: 15 C: 20	00006429
T3		C-Profil / C-profile 1118 mit Bohrungen/with holes	A: 4 B: 10 C: 12	00006427
T4		C-Profil / C-profile 1140	B: 1	61001501
T5		C-Profil / C-profile 1160	B: 2 C: 4	00006510
T6		C-Profil / C-profile 1220	B: 3 C: 4	00005258
T7		C-Profil / C-profile 2320	B: 1 C: 1	00006426
T8		C-Profil / C-profile 2320 mit Bohrungen/with holes	A: 1	00006194
T9		C-Profil / C-profile 2398 mit Bohrungen/with holes	A: 4	00006428
T10		C-Profil / C-profile 2480	A: 1	00005257
T11		C-Profil / C-profile 3597	C: 1	-
T12		C-Profil / C-profile 3598 mit Bohrungen/with holes	B: 6 C: 8	61001504
T13		C-Profil / C-profile 3679	B: 2 C: 2	00006516

ART.	OVERVIEW	NAME	QTY	ERP
T14		Platte / Plate	A: 1 B: 11 C: 15	A: 00006431 B,C: 00006612
T15		Platte für Absaugung / Plate for ventilation	A: 1 B: 1 C: 1	A: 00006432 B,C: 00006613
T16		Abdeckblech für E-Profil / Cover plate for E-profile	A: 3 B: 6 C: 8	00006440
T17		Abdeckblech für E-Profil kurz/ Cover plate for E-profile short	B: 1 C: 1	00006530
T18		Abdeckblech für A-Profil / Cover plate for A-profile	A: 2 B: 3 C: 3	00006438
T19		Abdeckblech für A-Profil kurz/ Cover plate for A-profile short	A: 2 B: 1 C: 1	00006439
T20		Sichtschutzblech / visibility protection sheet 110 - 90°	A: 3 B: 3 C: 3	00006435
T21		Winkelblech / angled sheet metal 90°	A: 6 B: 23 C: 33	00006436
T22		Verbindungsblech U-Form/ connecting plate U-shape	A: 3 B: 12 C: 12	00006437
T23		Verbindungsblech X-Form/ connecting plate X	B: 4 C: 6	00006512
T24		Winkelblech / angled sheet metal 45°	C: 18	00005338

ART.	OVERVIEW	NAME	QTY	ERP
N1		ISO 7380 – M8x16	A: 71 B: 235 C: 373	00003962
N2		ISO 4762 – M8x35	A: 12 B: 22 C: 26	00003795
N3		ISO 7500E – M8x65	A: 8 B: 28 C: 37	00003822
N4		Hammermutter / Hammer nut 10 M8	A: 71 B: 235 C: 373	00005357
N5		Nutenstein / Slot stone 10 M8	A: 12 B: 22 C: 26	00003789
N6		Gewindeformverbinder	A: 2 B: 25 C: 35	00003998
N7		Keilprofil		00006041

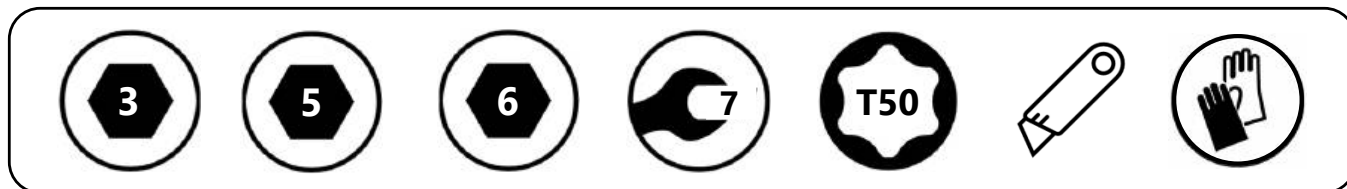
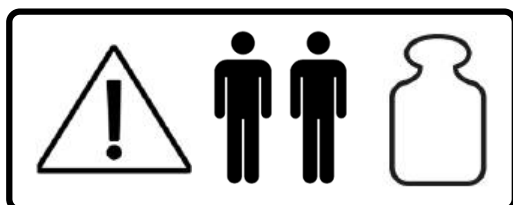

Dach / Roof

A. 2400x2400

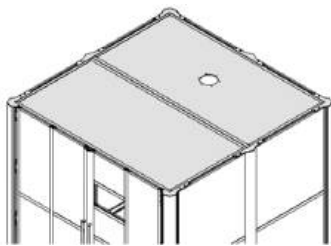

B.1 (A)

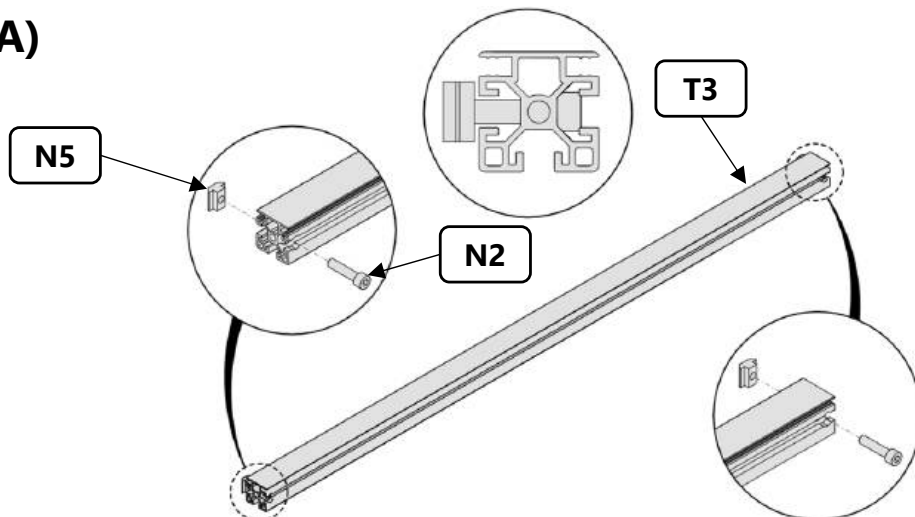

x4



B.2 (A)

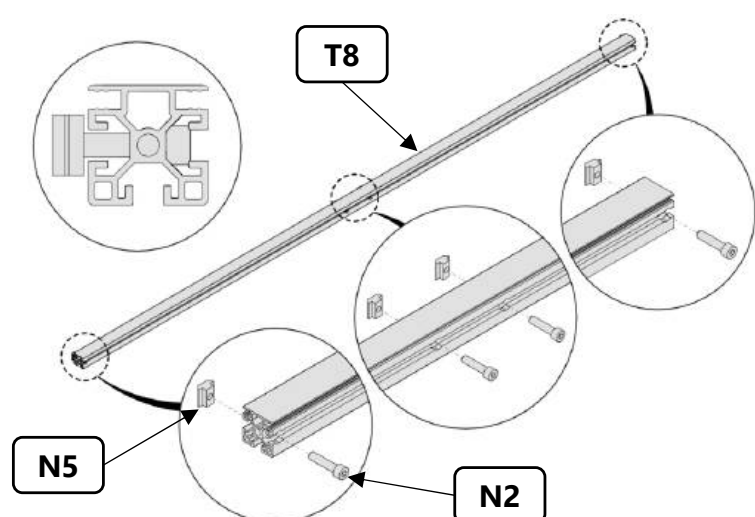

x1



B.3 (A)

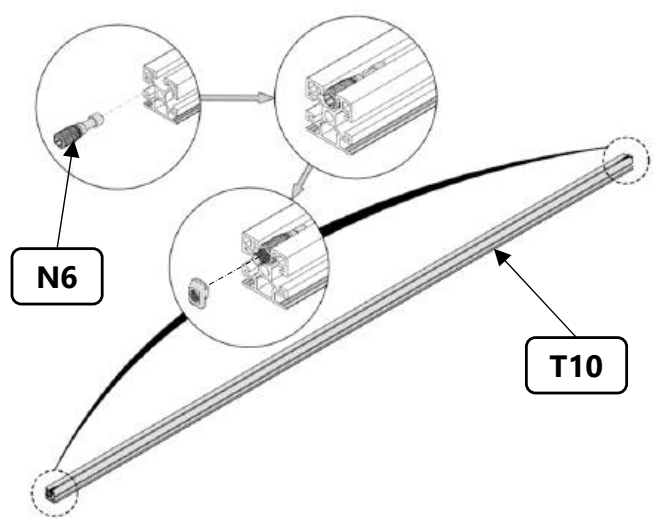

x1



B.4-1 (A)

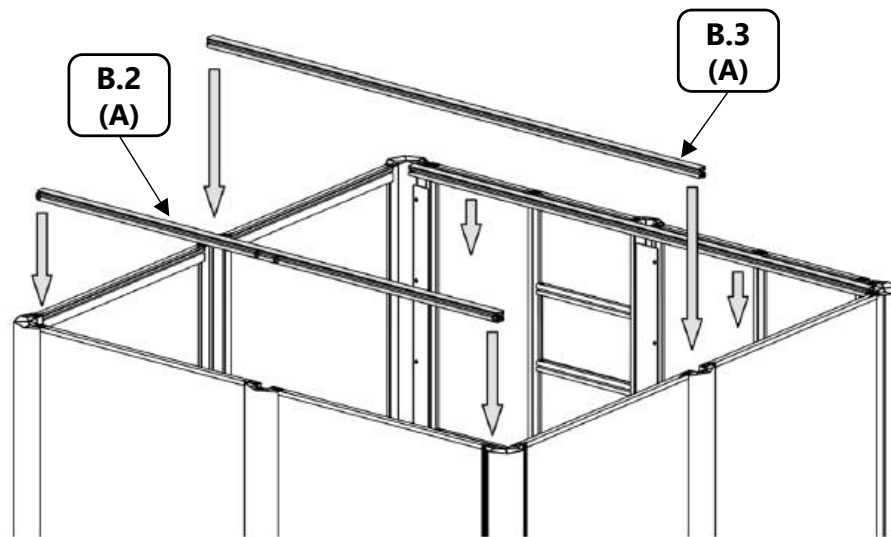

B.4-2 (A)

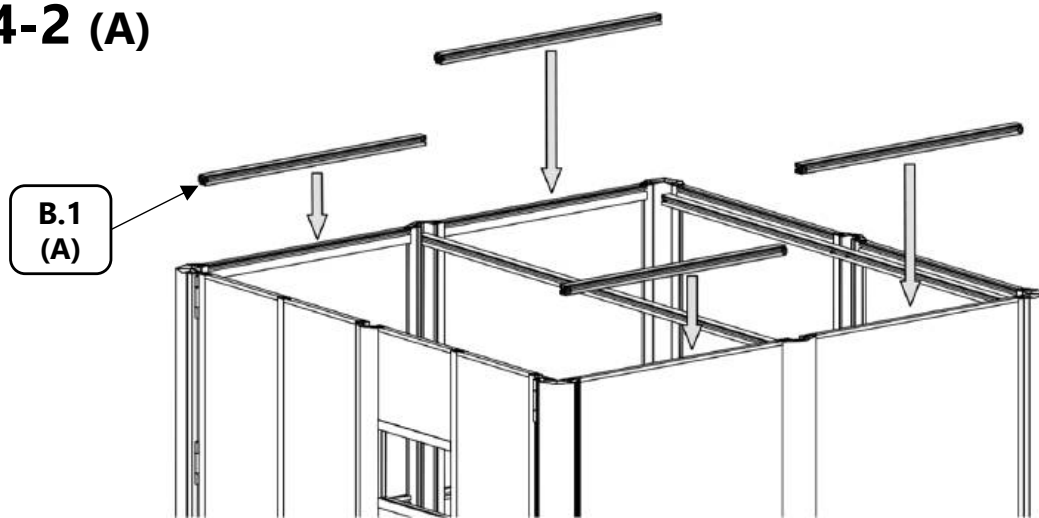

B.4-3 (A)

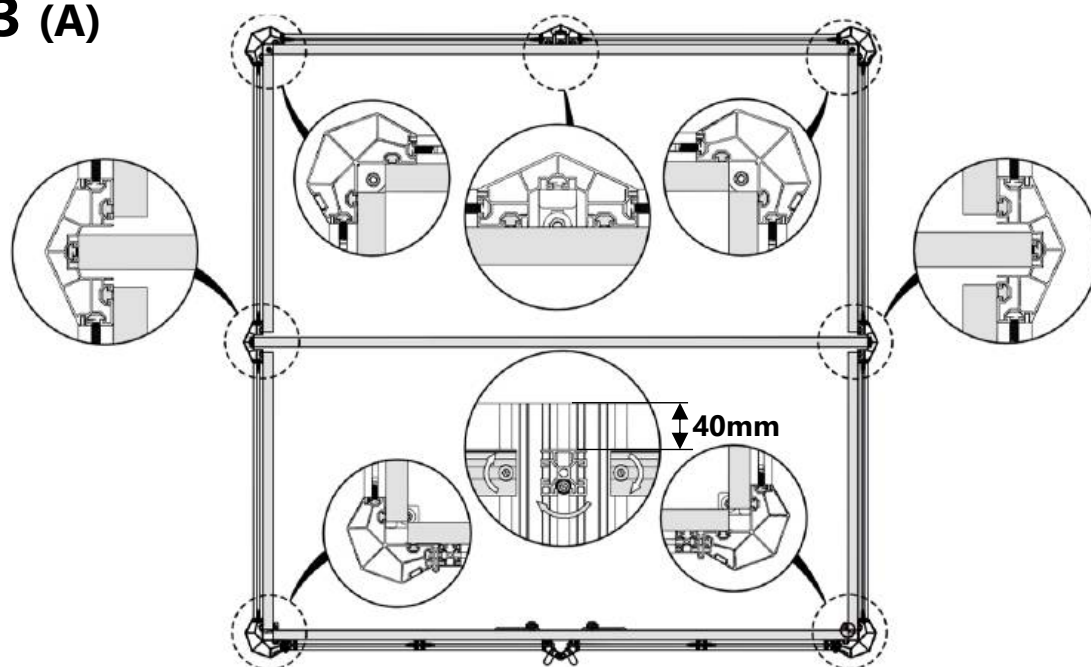

B.5 (A)

Siehe Montageanleitung
Laserschweißzelle!

See assembly-instructions
for Laser welding cell!

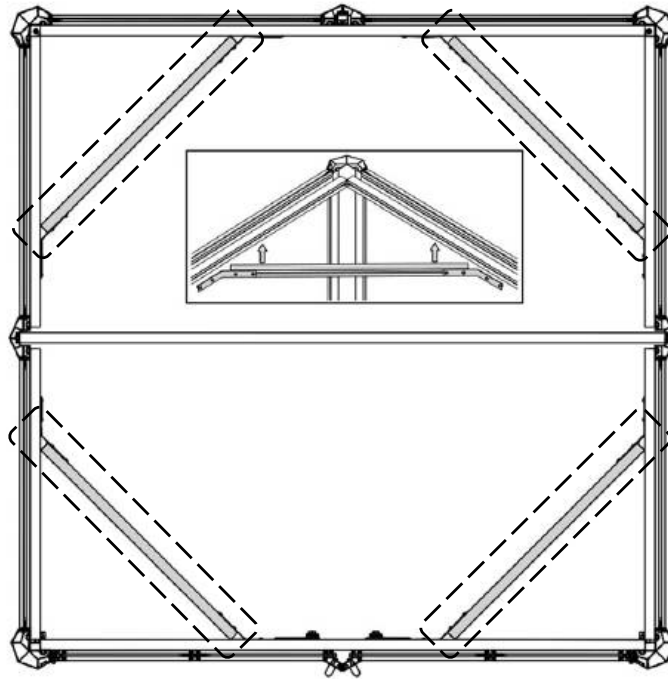

B.6 (A)

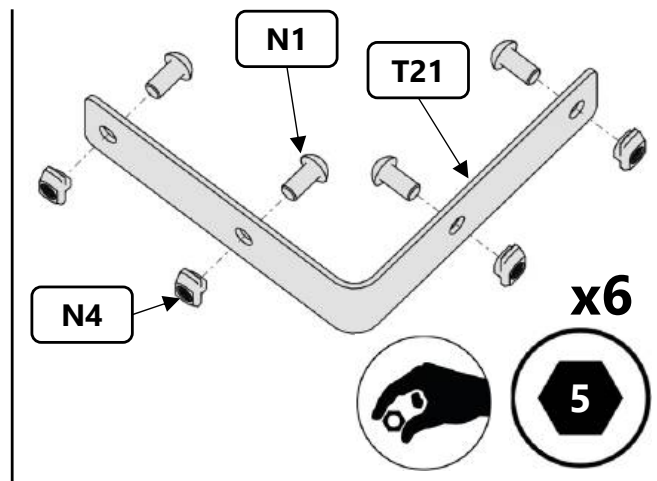
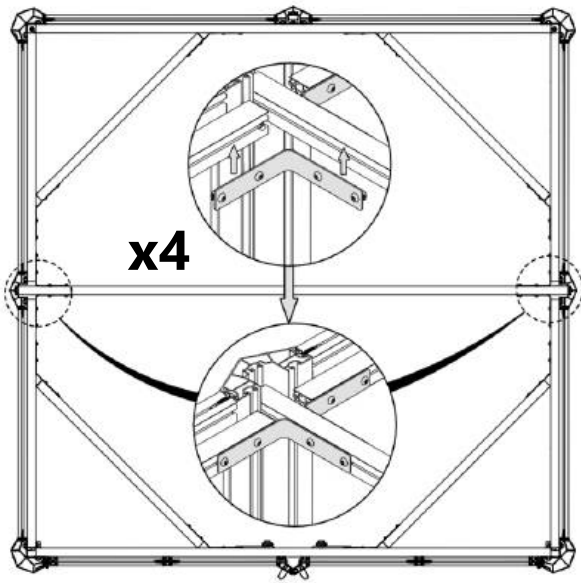

B.7 (A)

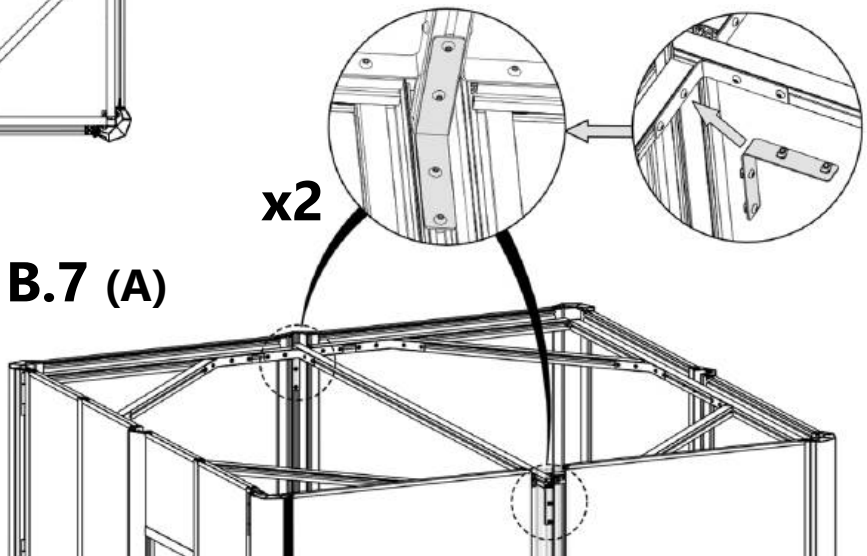

B.8 (A)

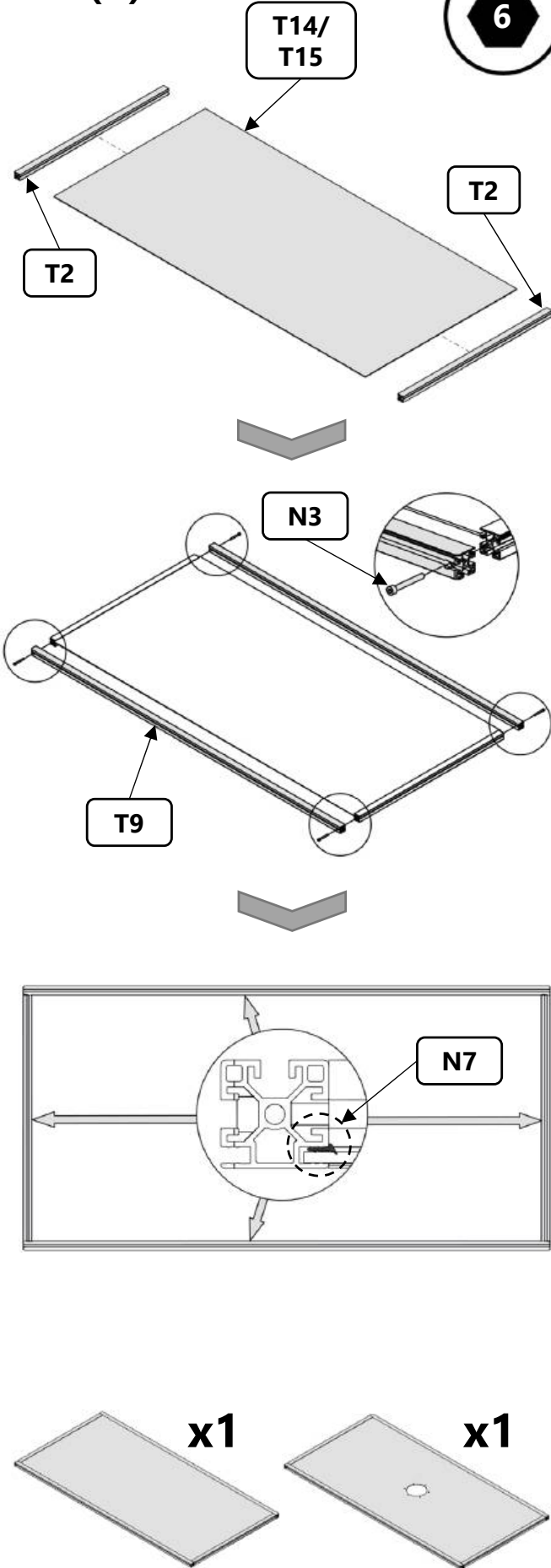

B.9 (A)

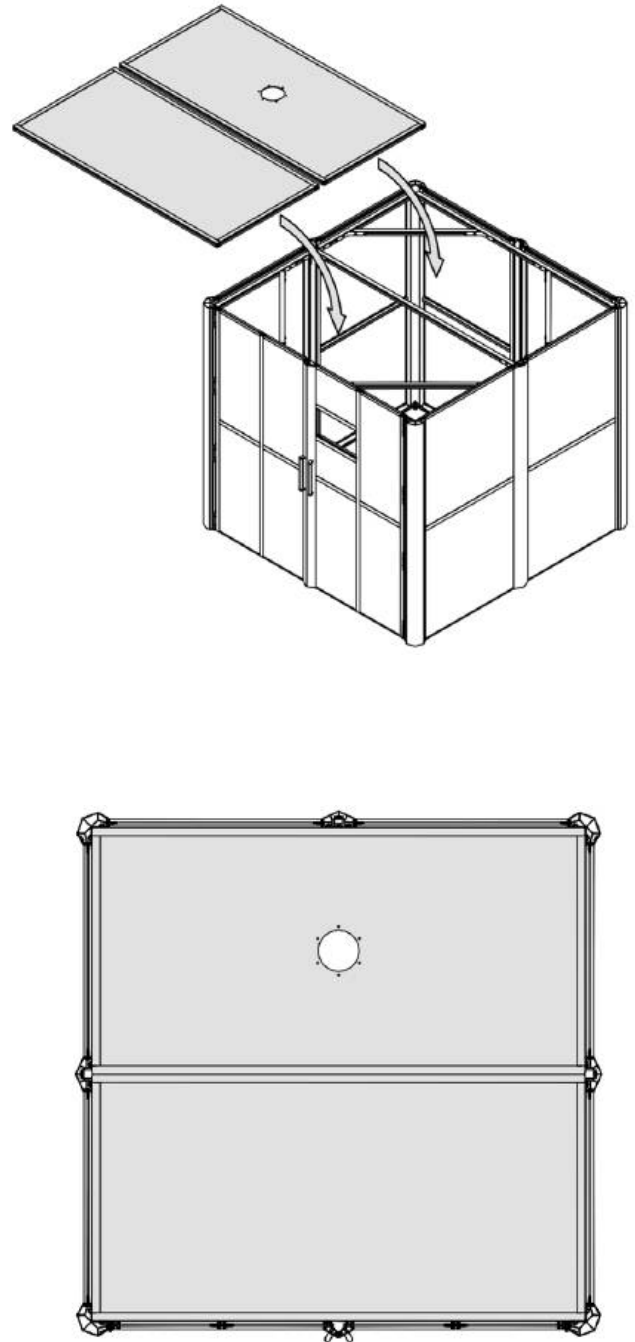

B.10 (A)

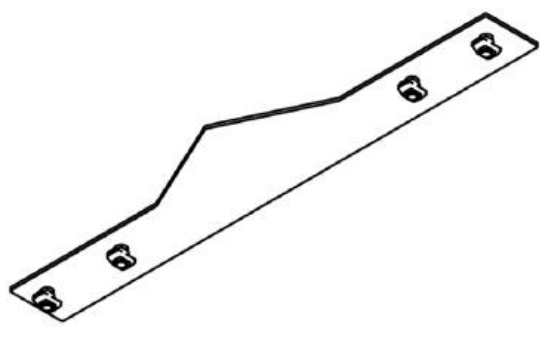
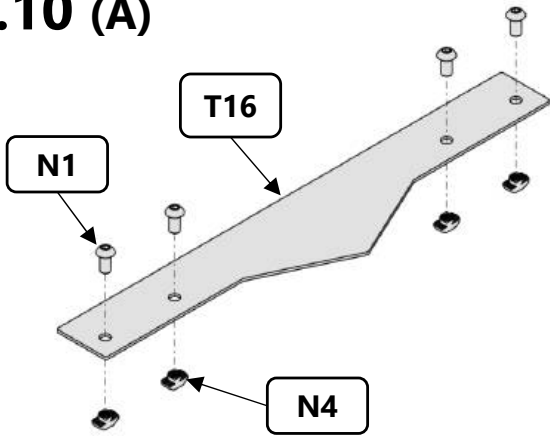

x3



B.11 (A)

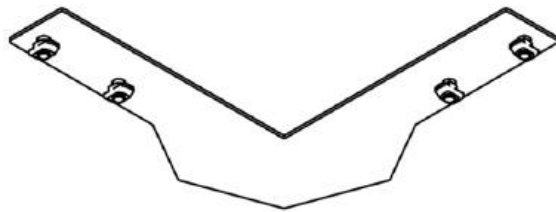
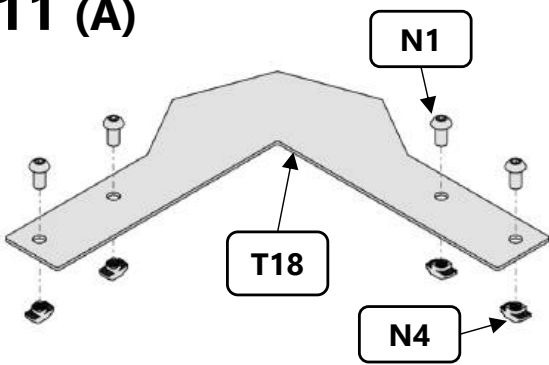

x2



B.12 (A)

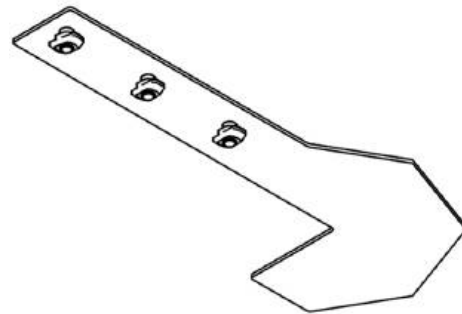
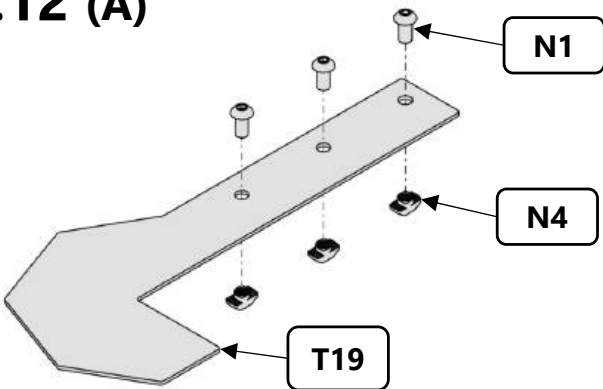

x1



B.13 (A)

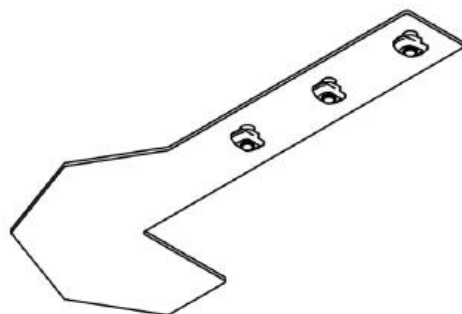
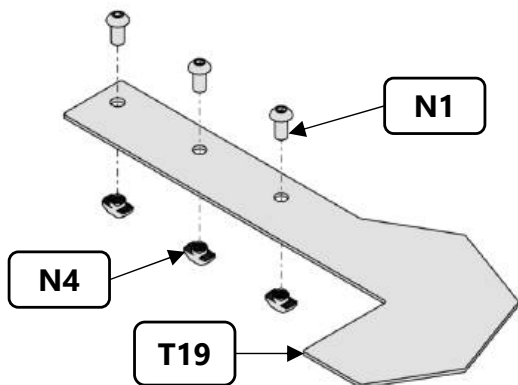

x1



B.14 (A)

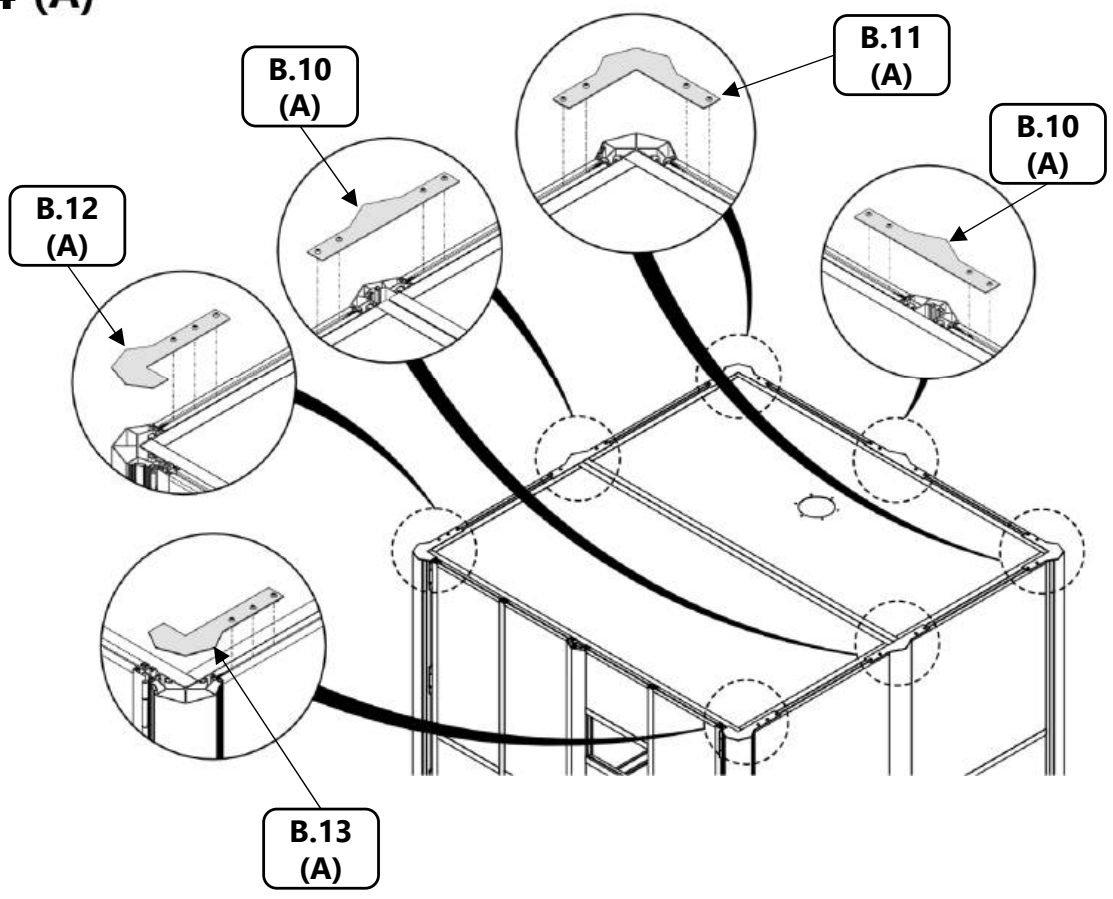

B.15 (A)

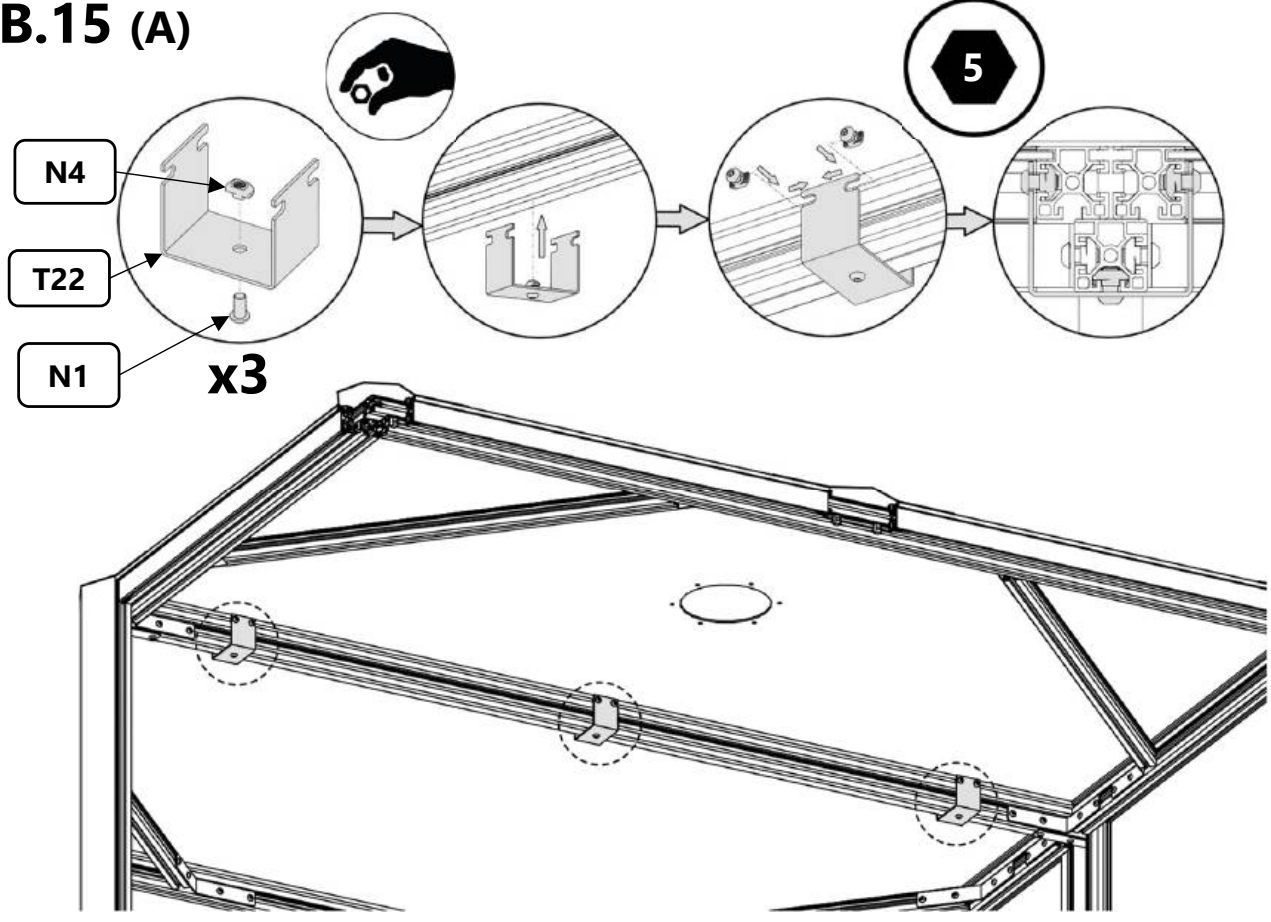

B.16 (A)

5

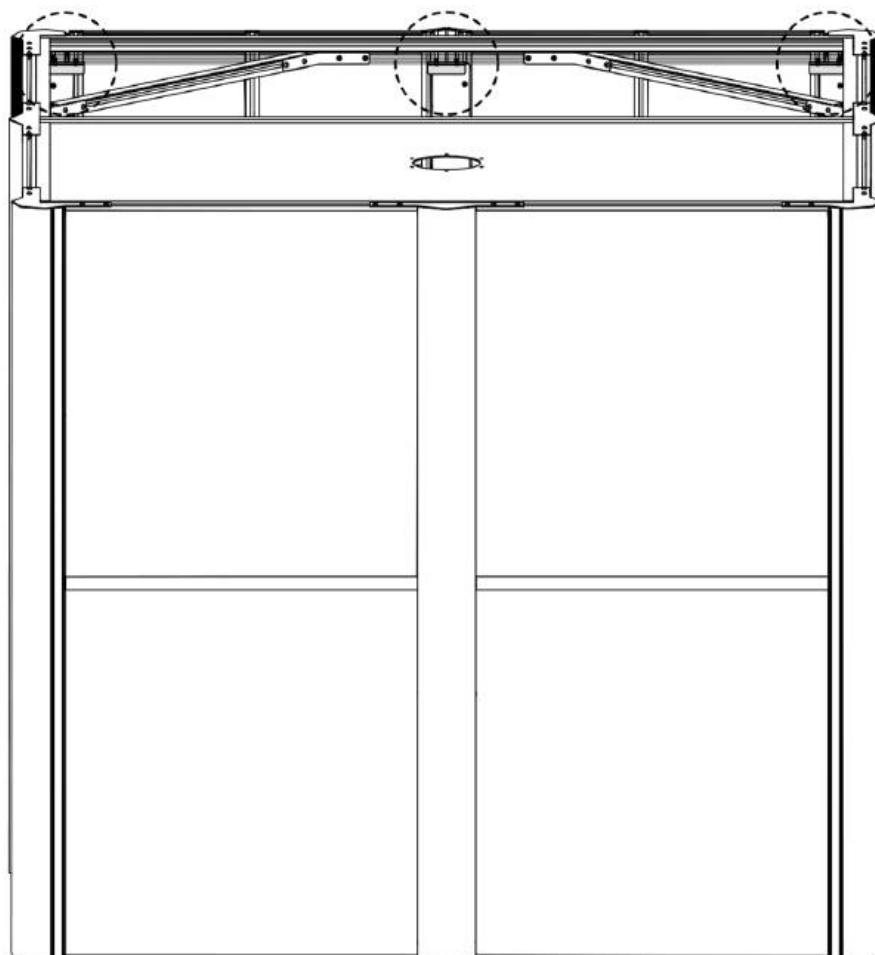
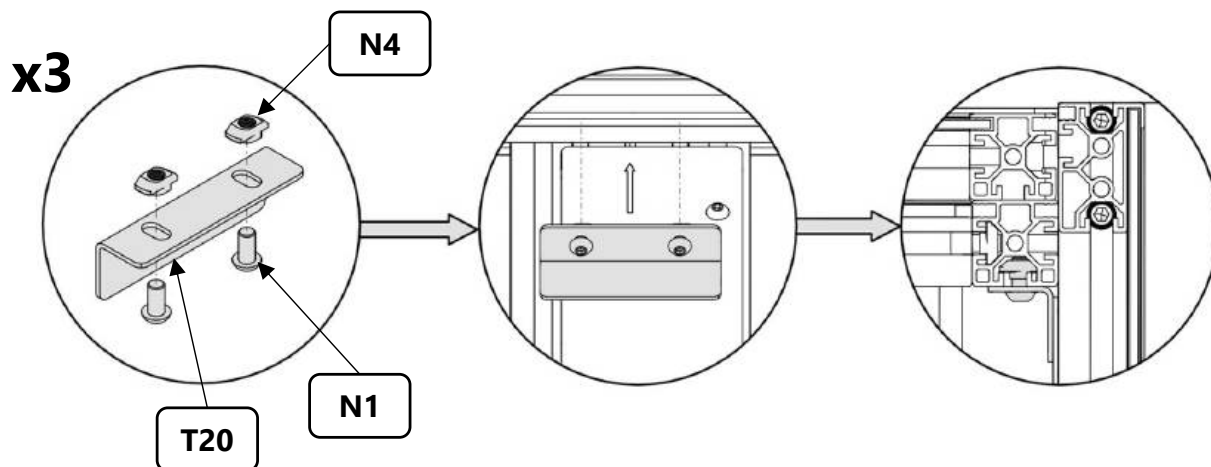

Dach / Roof

B. 3600x3600

C. 4800x3600

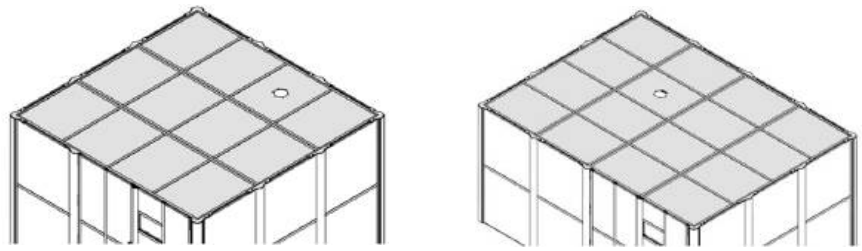

B.1 (B,C)

B: x10

C: x12

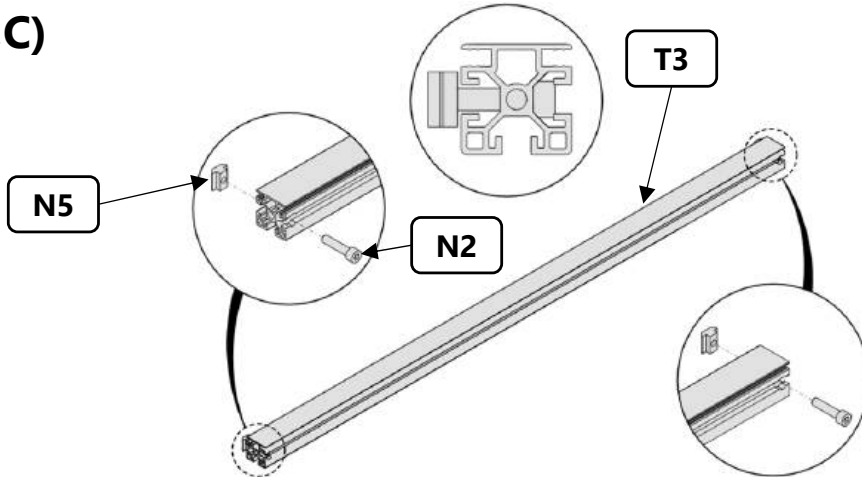

B.2 (B,C)

B: x1

C: x1

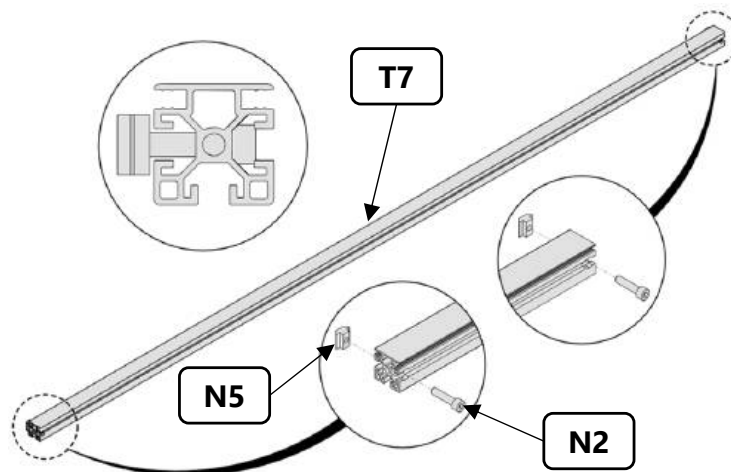

B.3 (B,C)

B: x2

C: x2

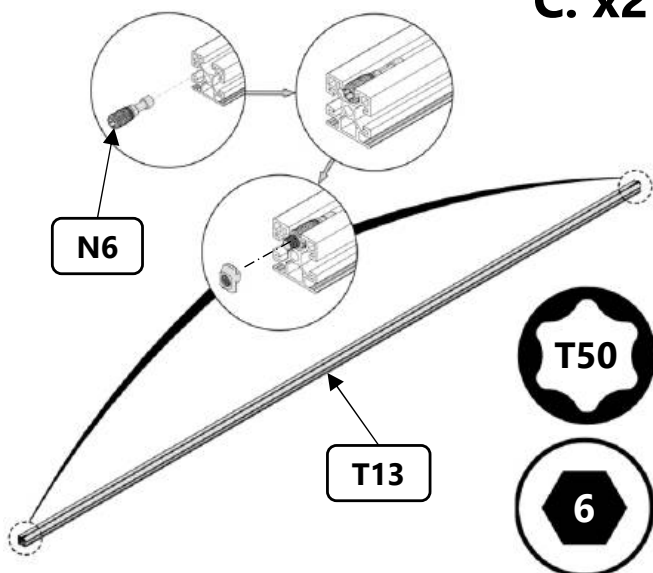

B.4 (C)

C: x1

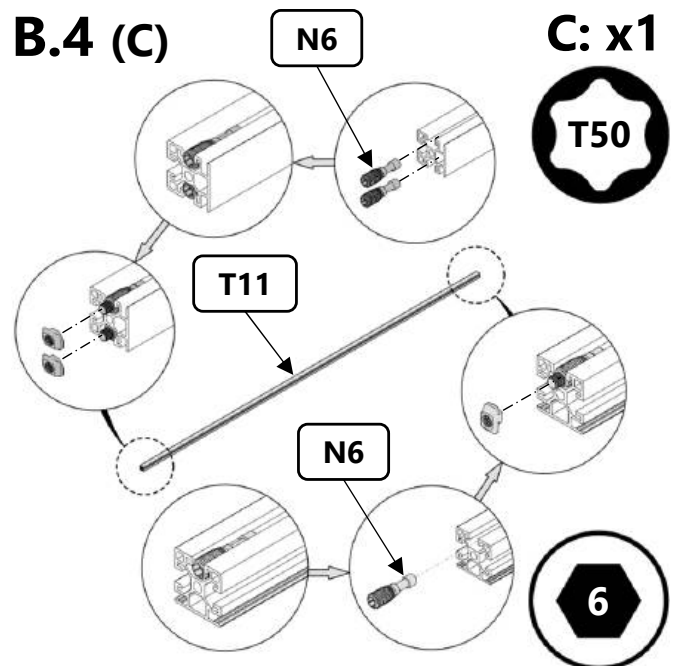

B.5 (B) nur/only 4800x3600 B: x1

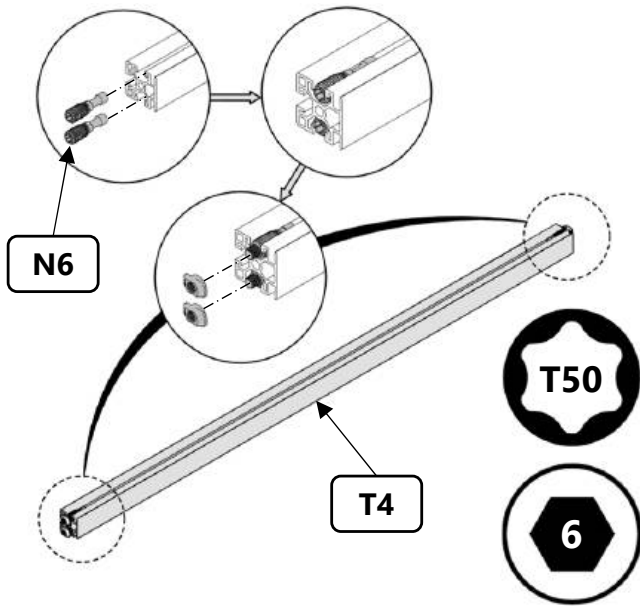

B.6 (B,C)

**B: x2
C: x4**

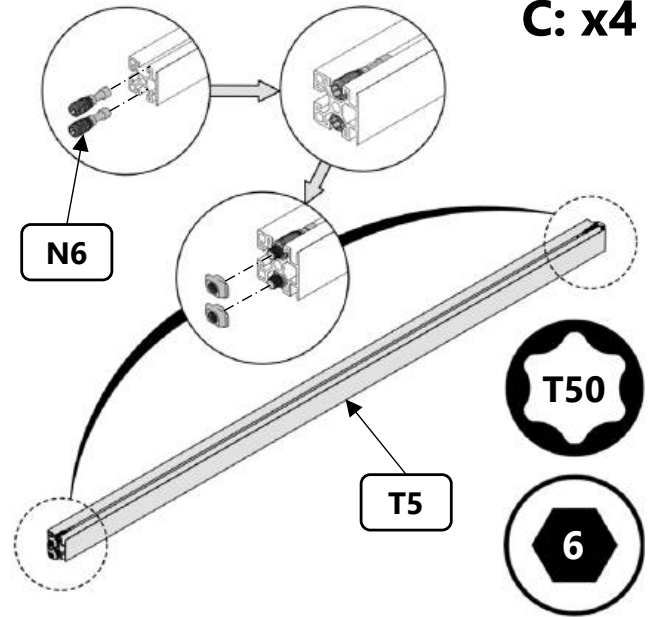

B.7 (B,C)

**B: x3
C: x4**

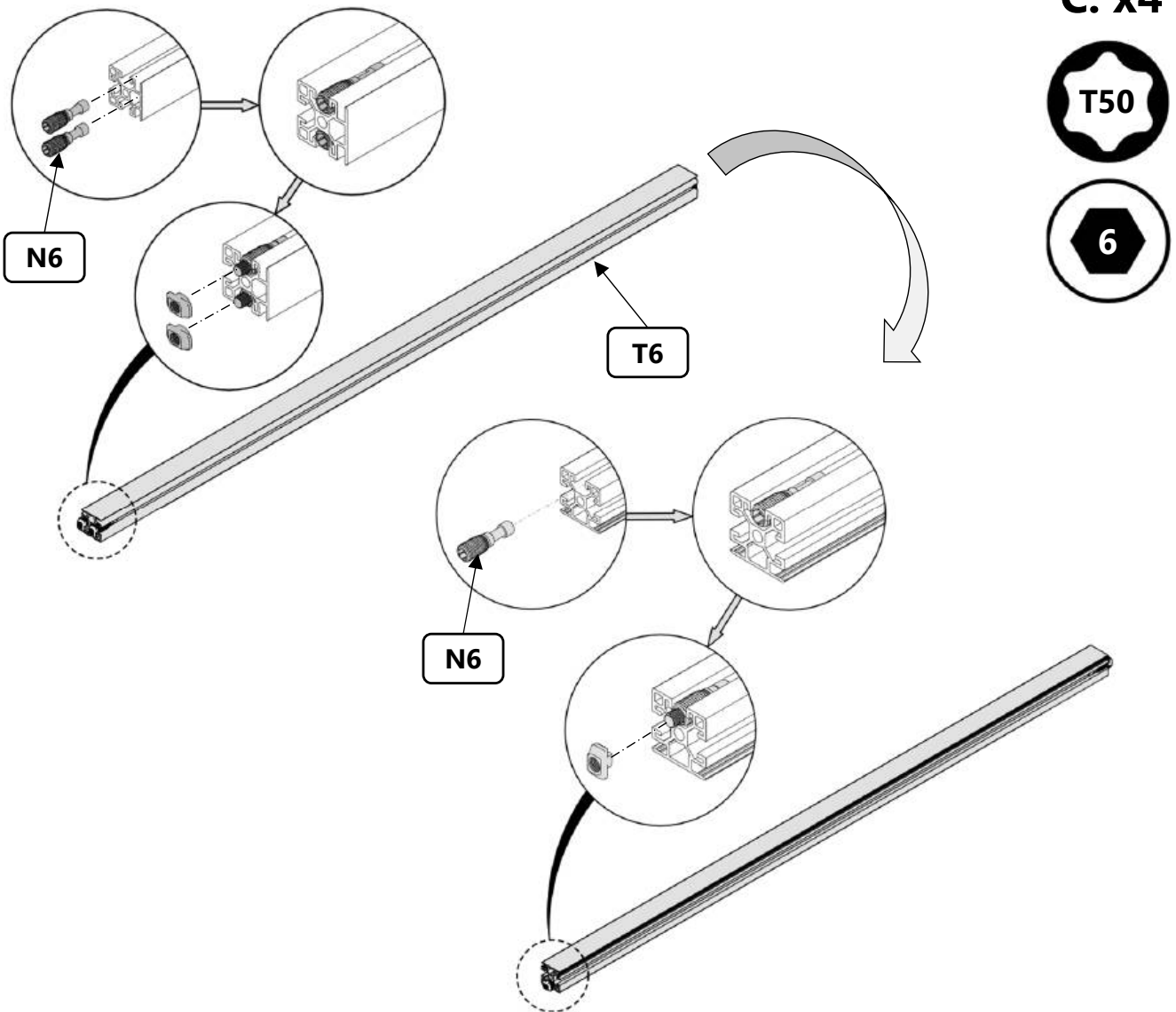

B.8-1 (B,C)

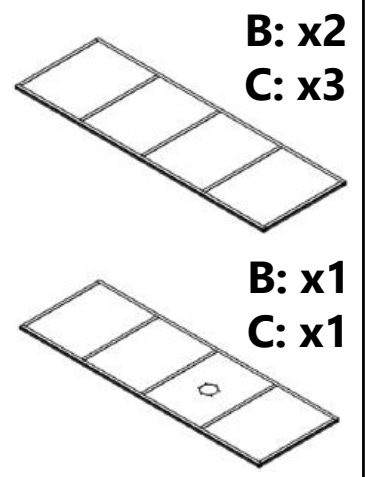
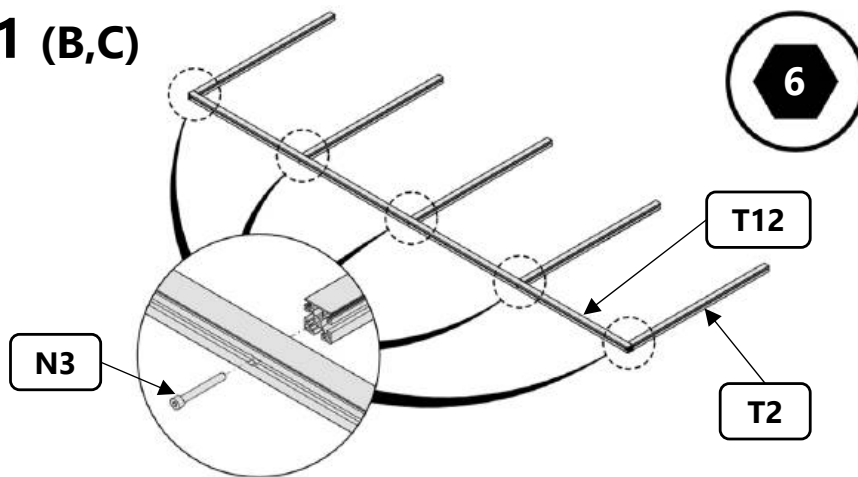

B.8-2 (B,C)

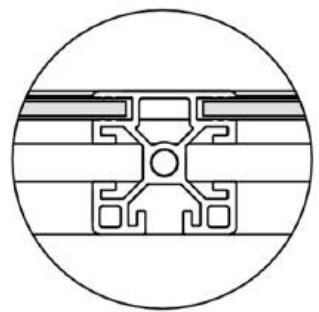
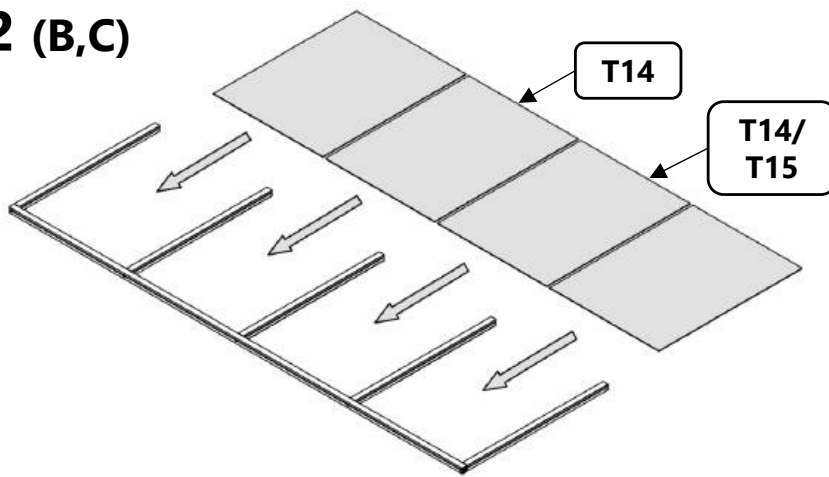

B.8-3 (B,C)

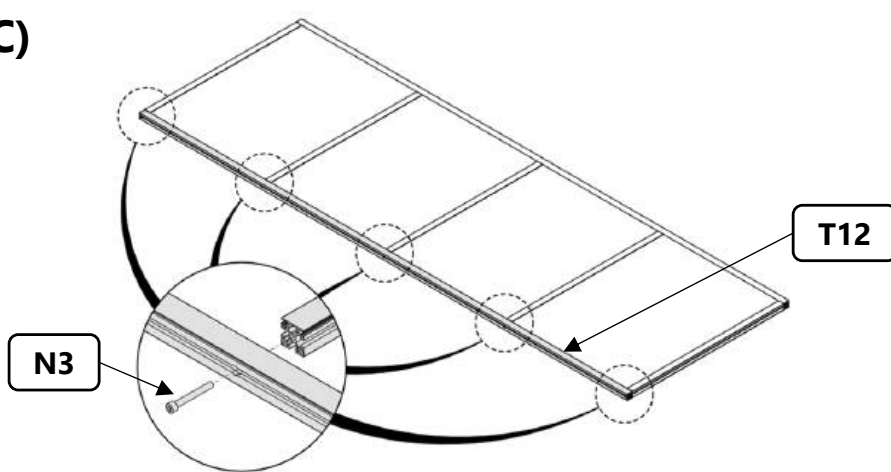

B.8-4 (B,C)

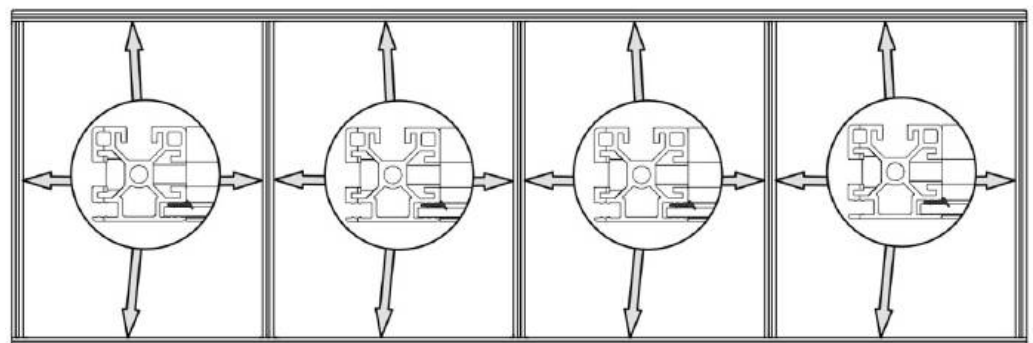
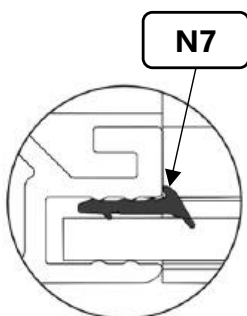

B.9-1 (B,C)

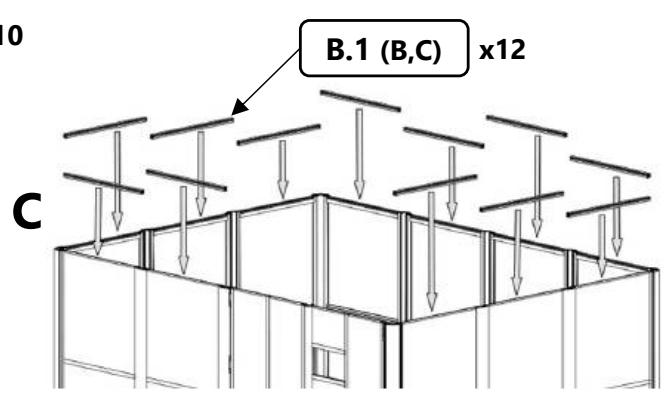
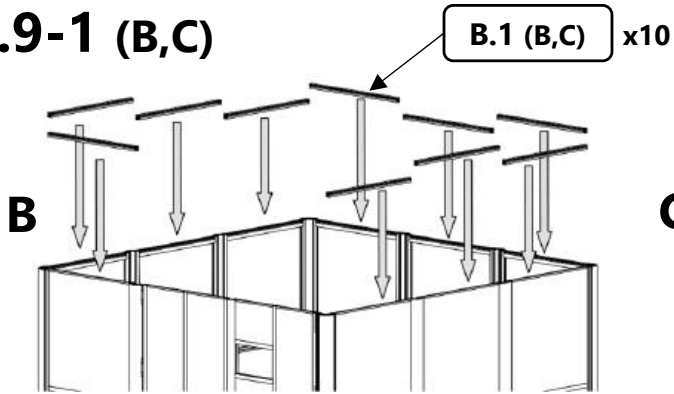

B.9-2 (B,C)

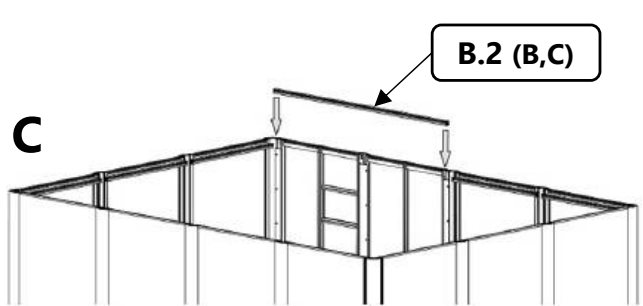
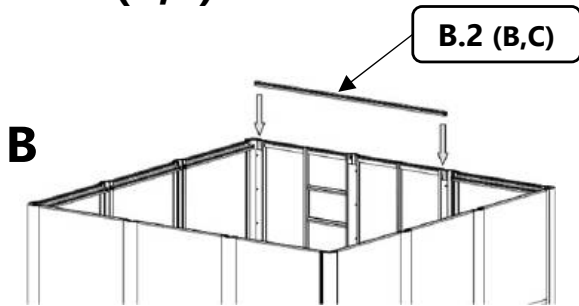

B.9-3 (B,C)

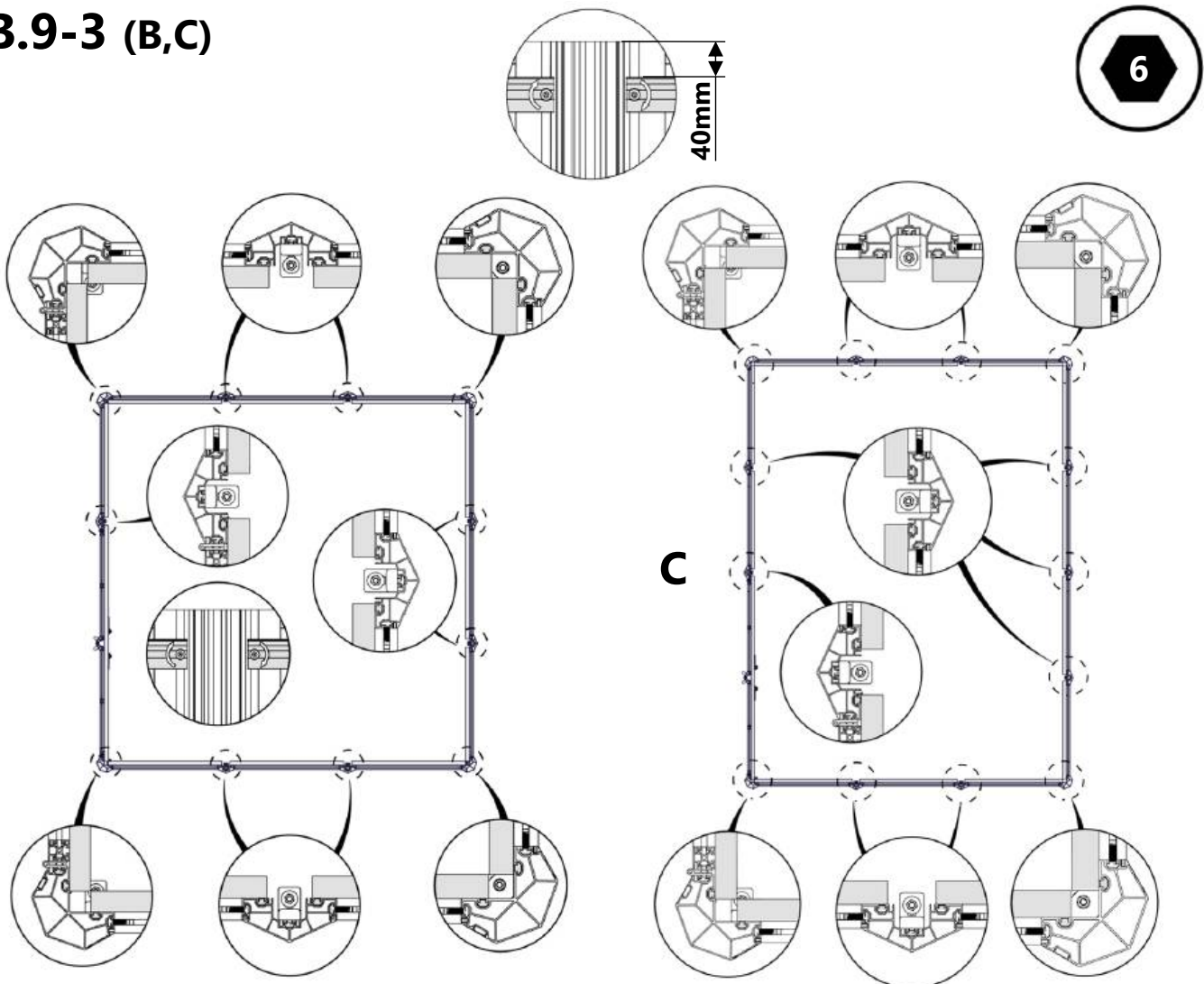

B.10-1 (B,C)

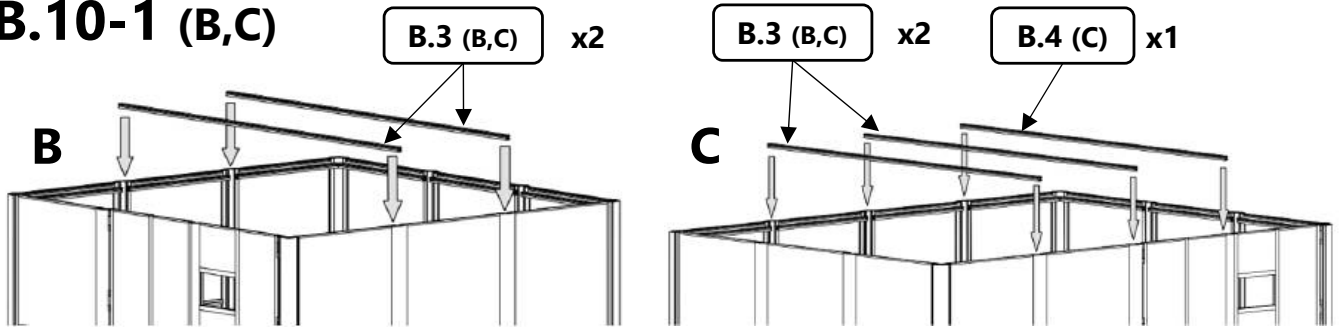

B.10-2 (B,C)

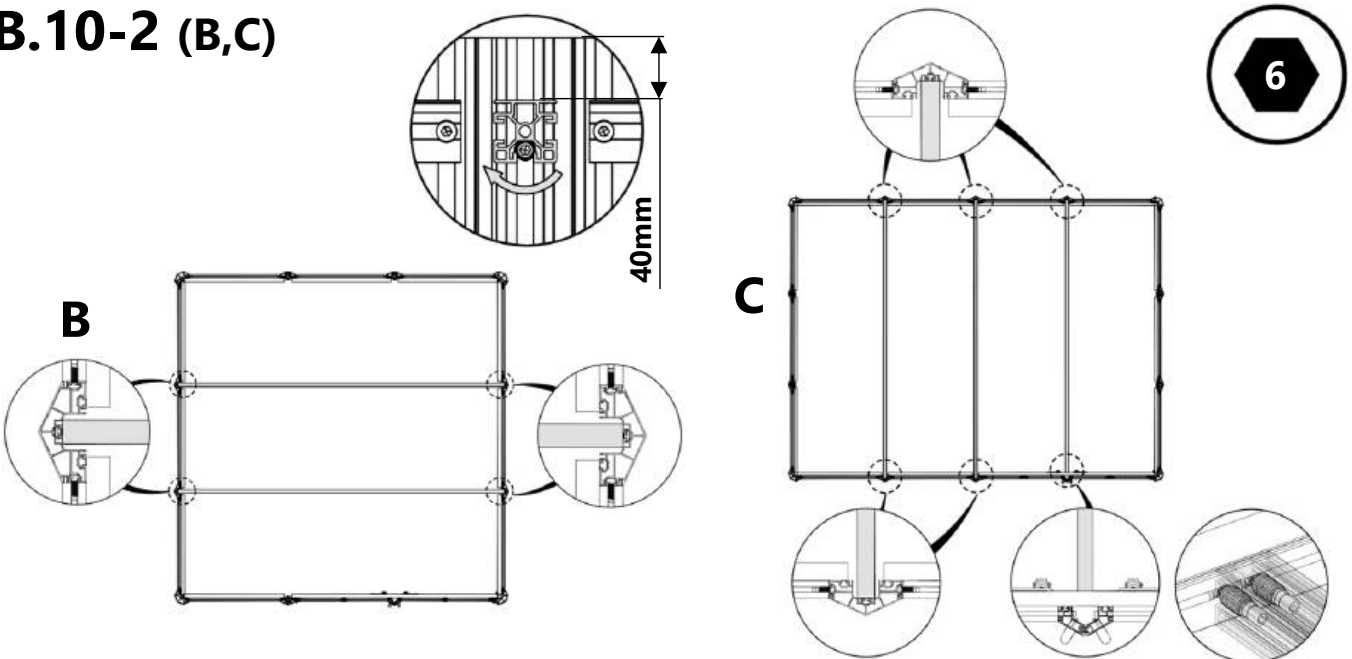

B.11 (B,C)

Siehe Montageanleitung
Laserschweißzelle!

See assembly-instructions
for Laser welding cell!

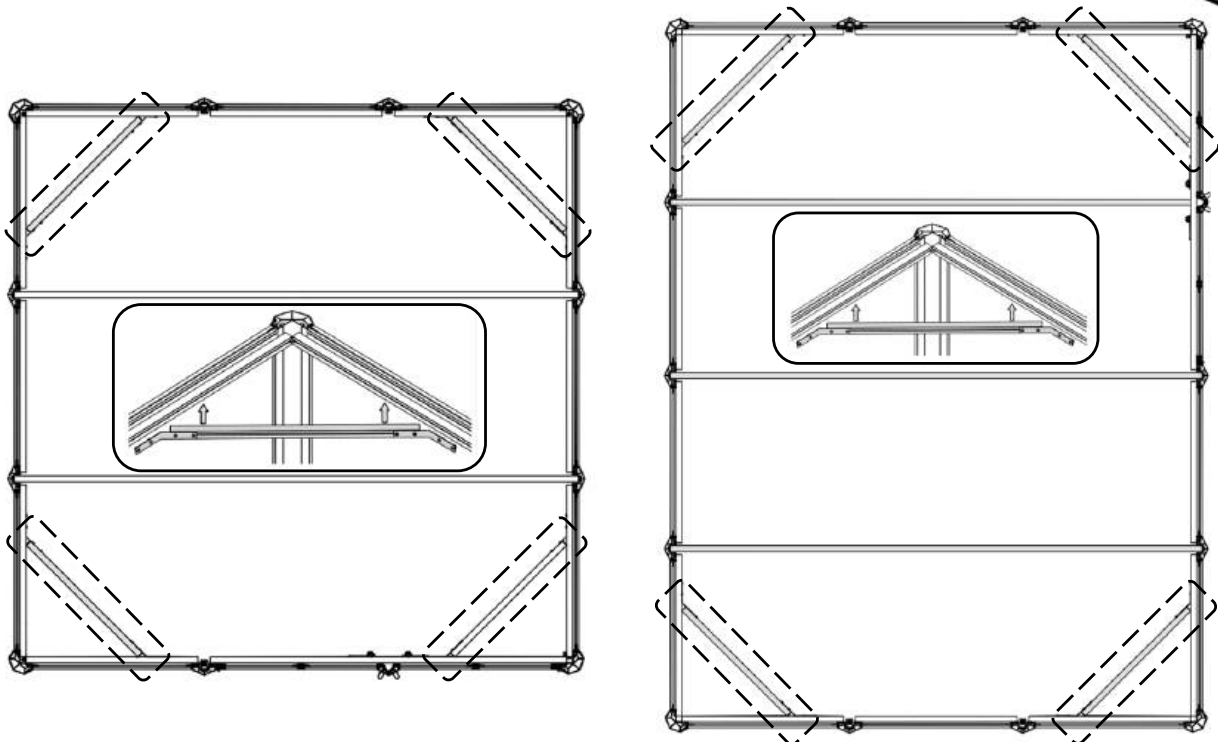

B.12 (B,C)

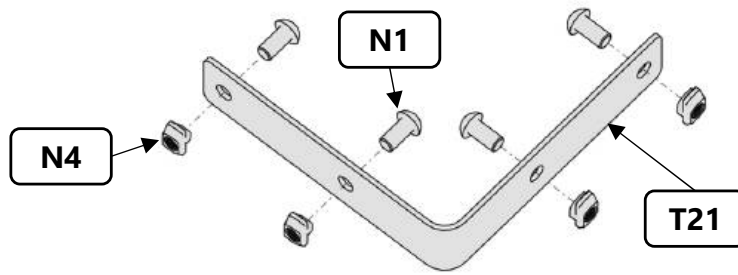

B: x23
C: x33



B.13-1 (B,C)

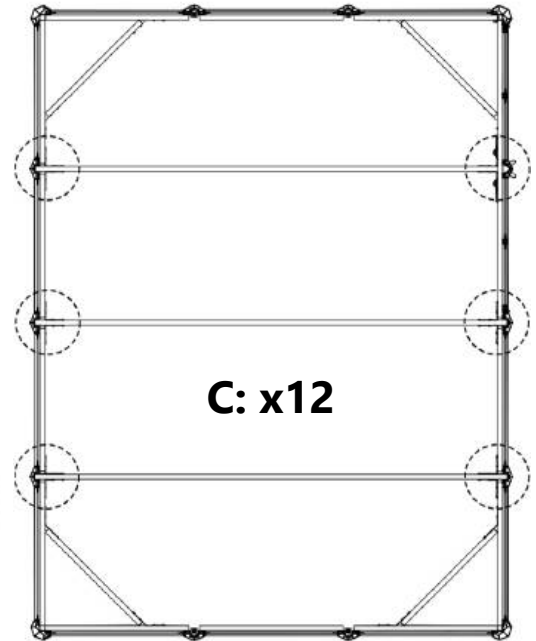
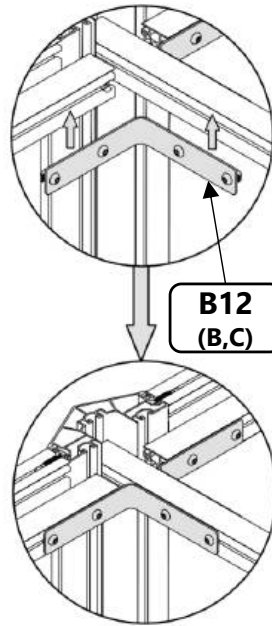
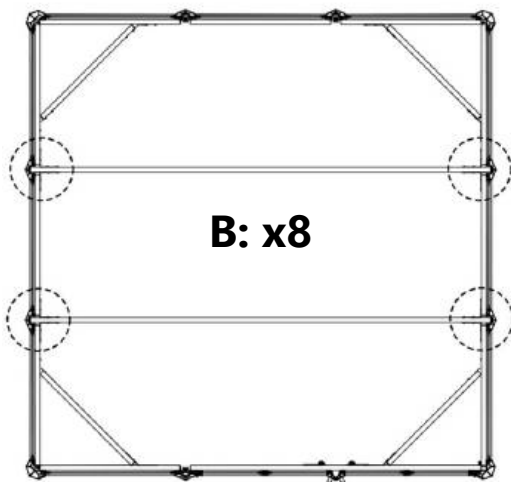

B.13-2 (B,C)

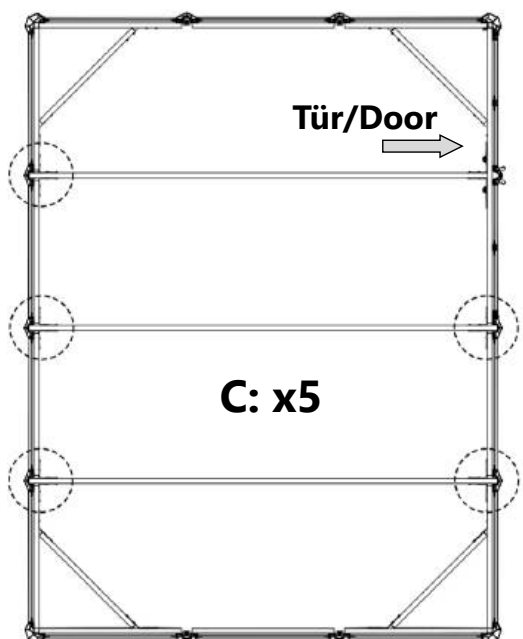
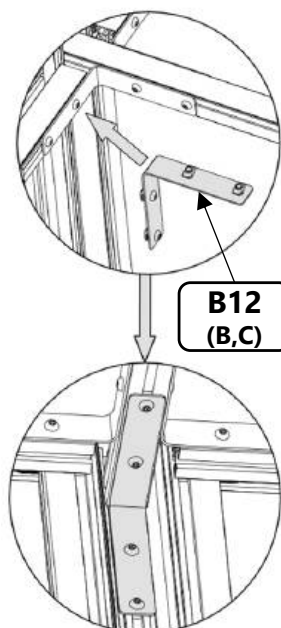
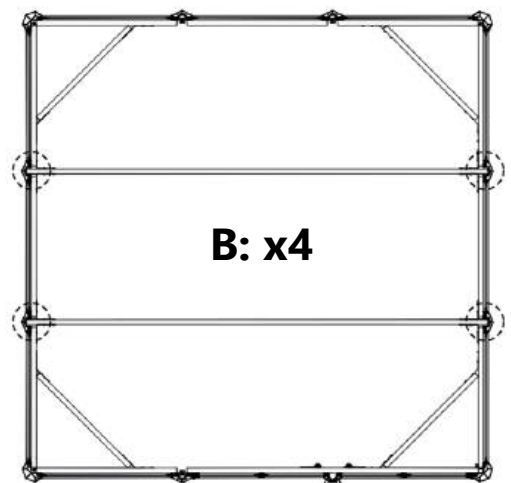

B.14 (B,C)

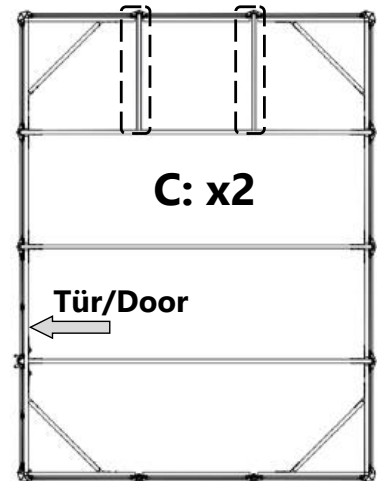
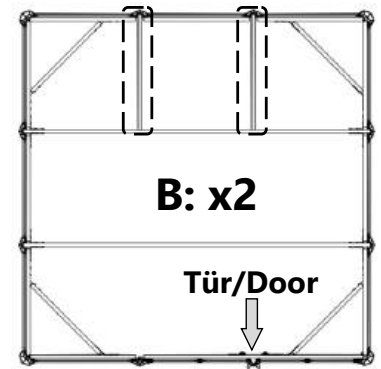
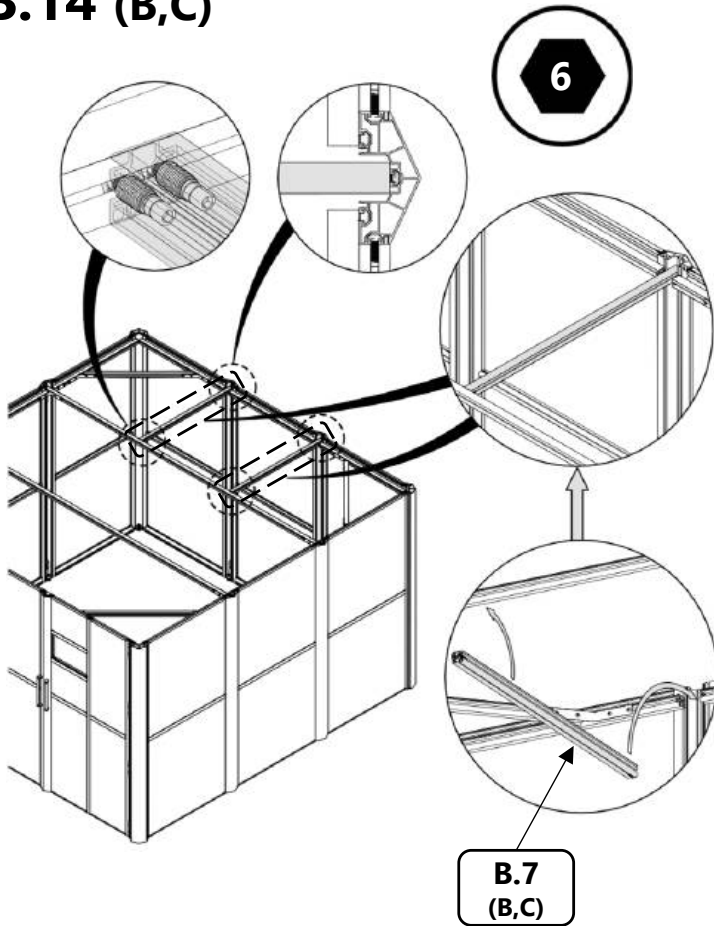

B.15 (B,C)

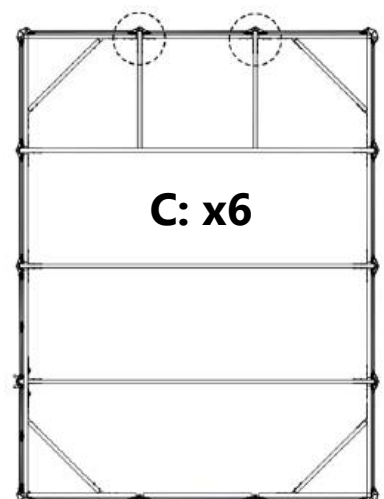
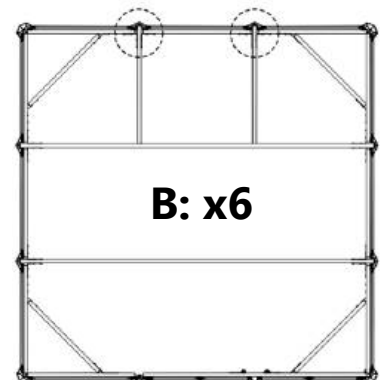
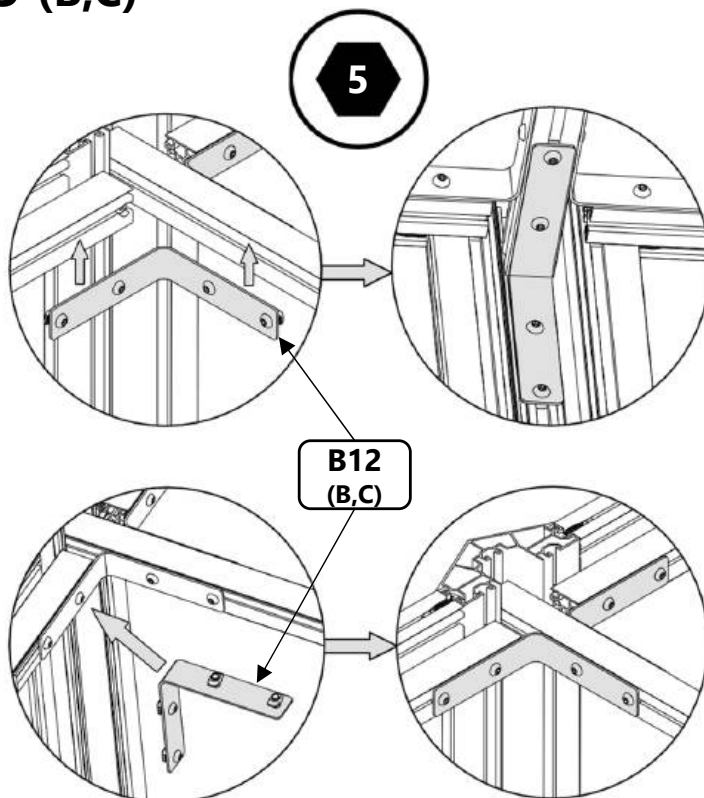

B.16 (B,C)

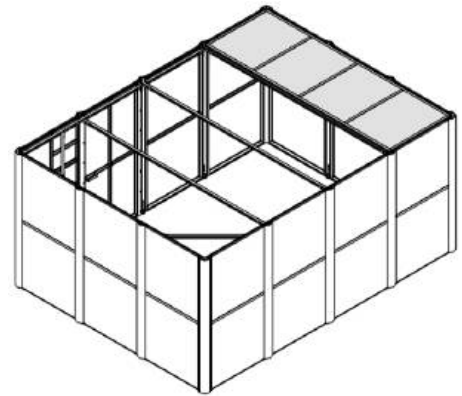
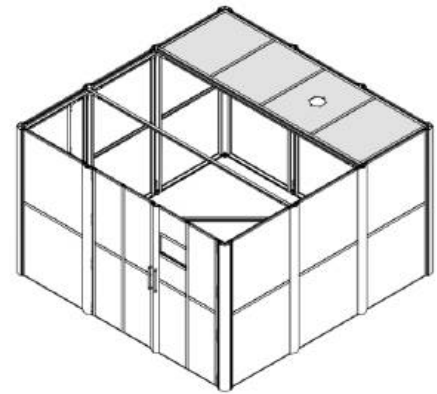
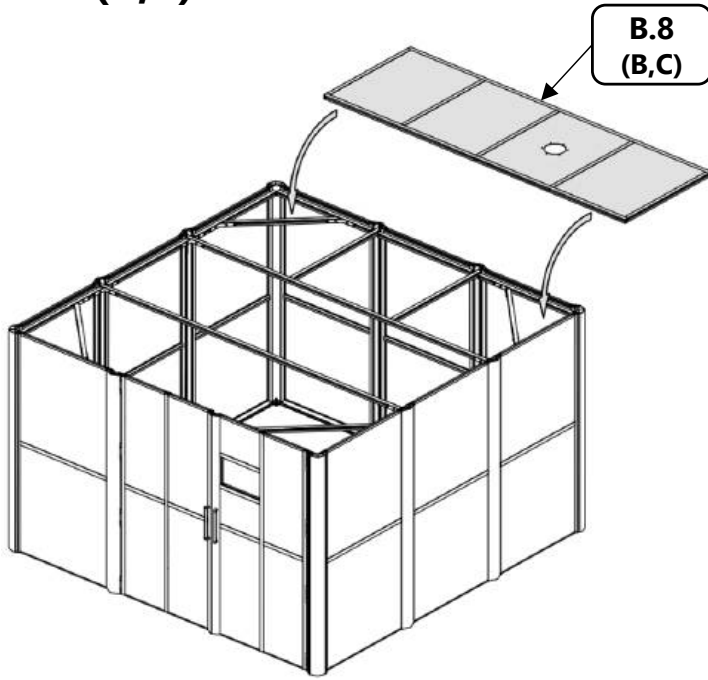

B.17 (B,C)

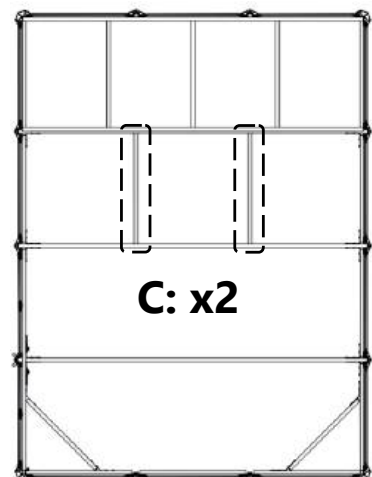
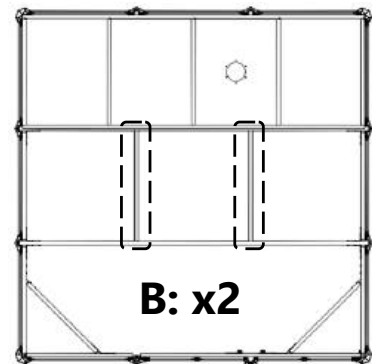
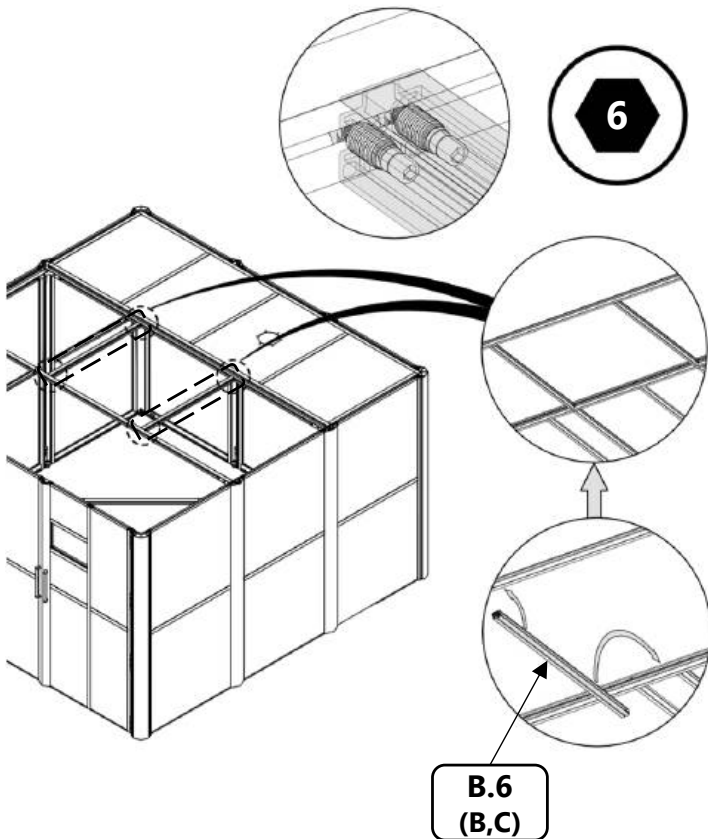

B.18 (B,C)

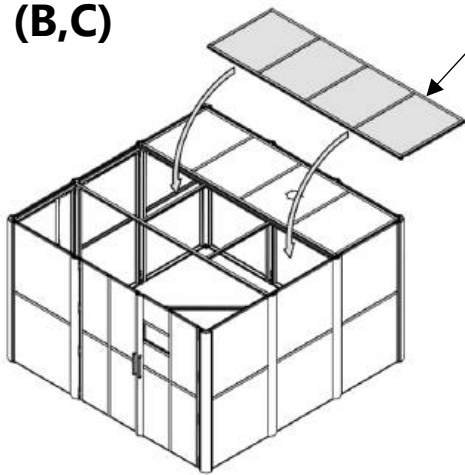

B.8
(B,C)

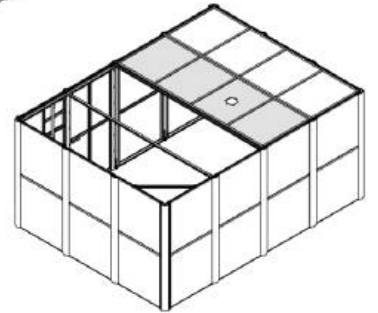
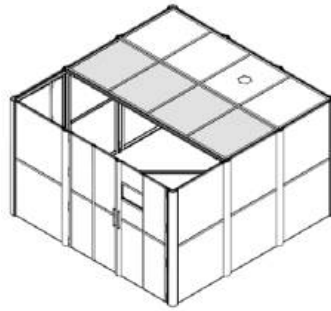

B.19 (C)

nur/only 4800x3600

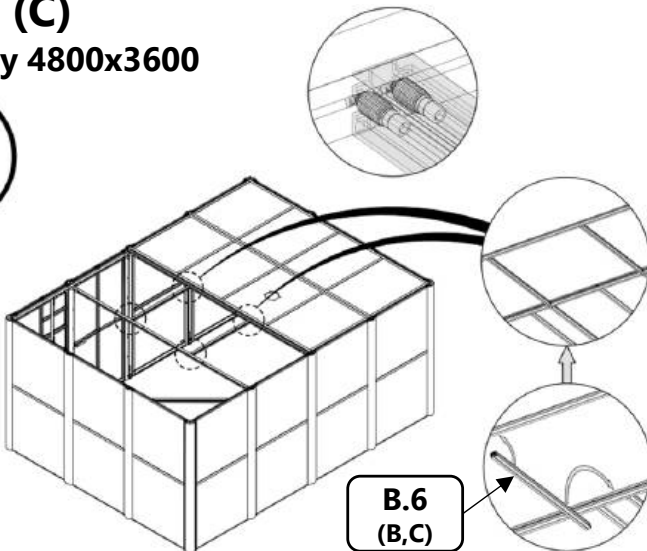

B.6
(B,C)

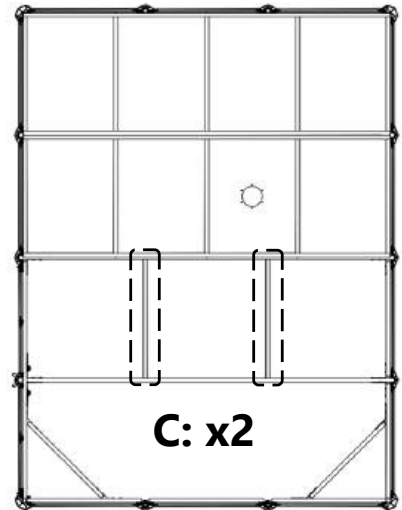

B.20 (C) nur/only 4800x3600

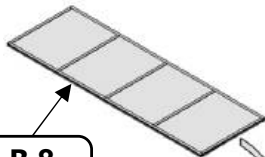

B.8
(B,C)

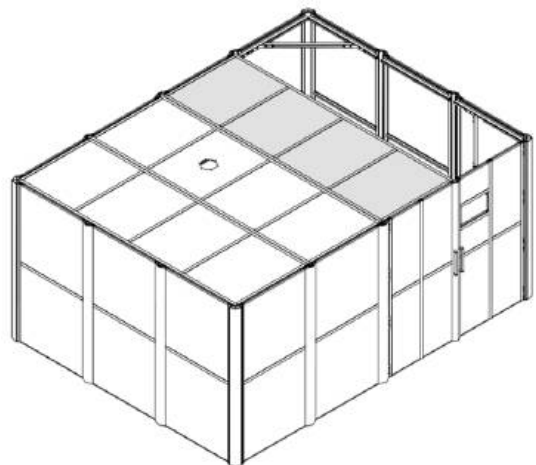
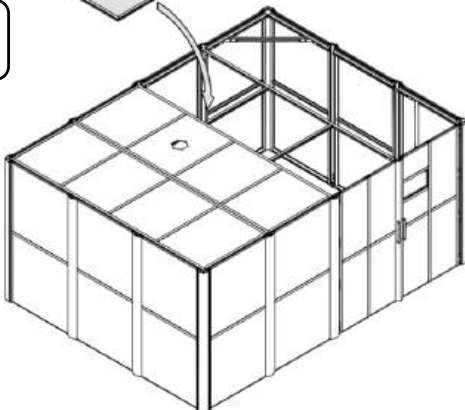

B.21 (B) nur/only 3600x3600

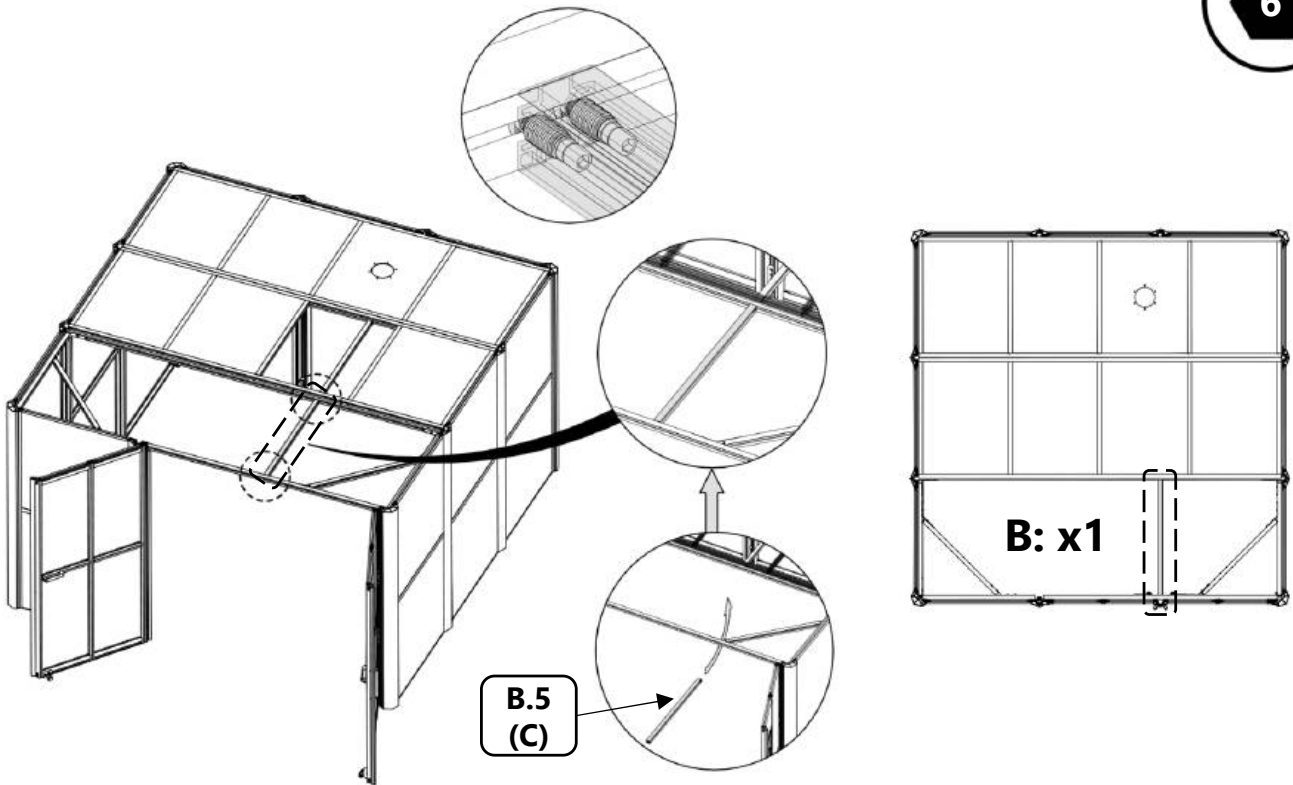

B.22 (B,C)

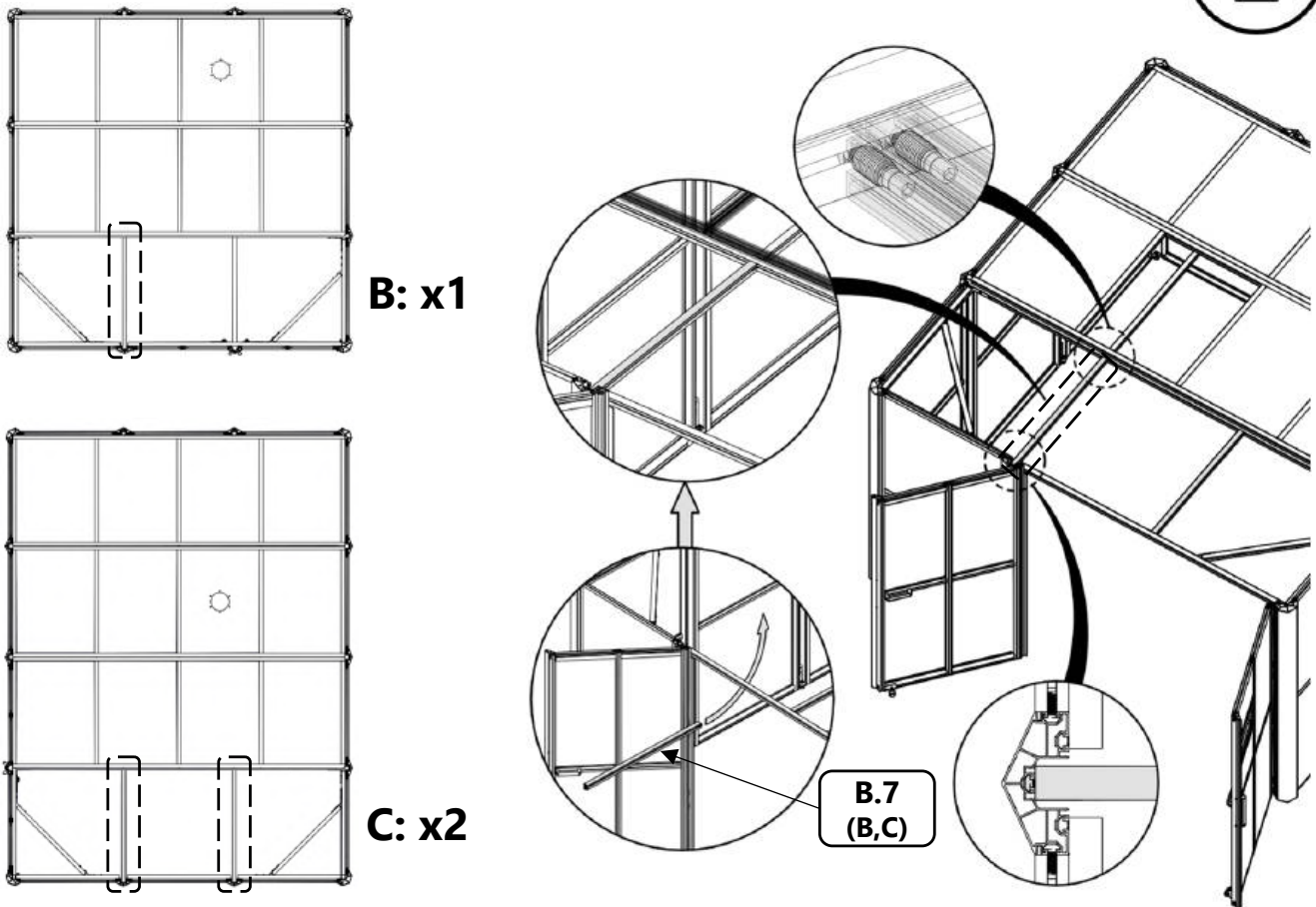

B.23 (B)

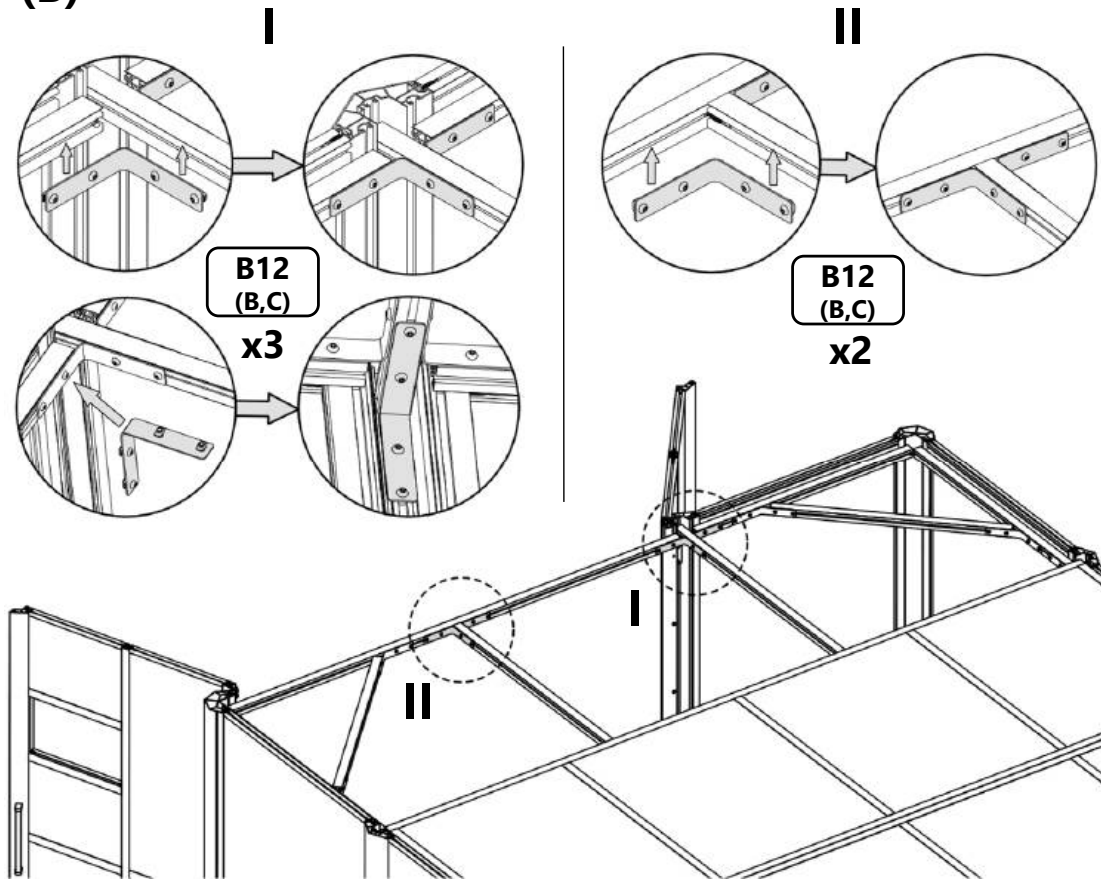

B.23 (C)

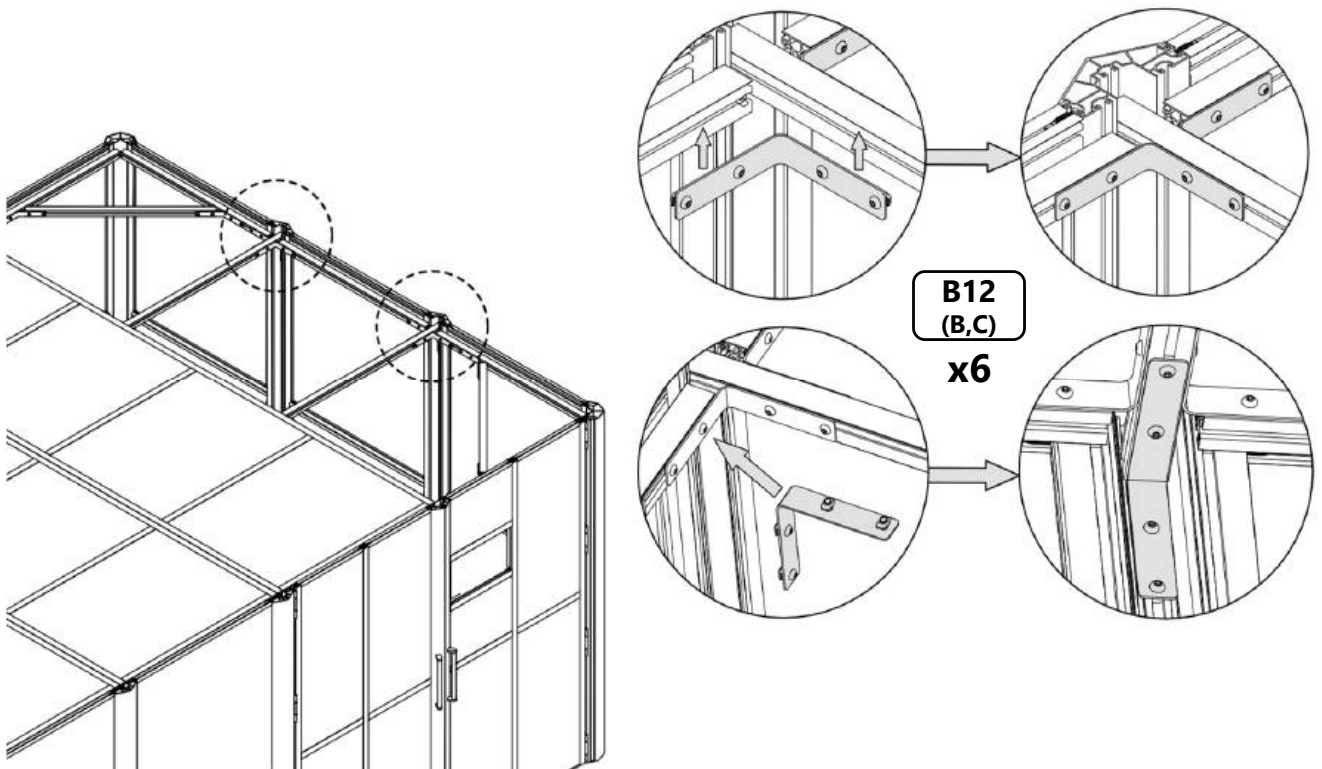

B.24 (B,C)

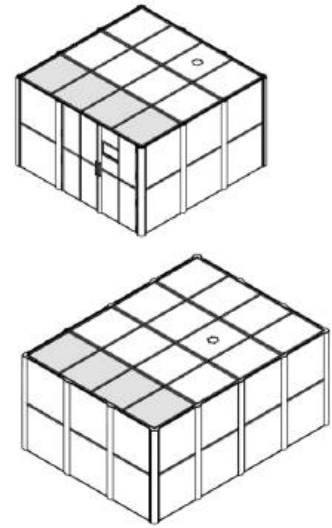
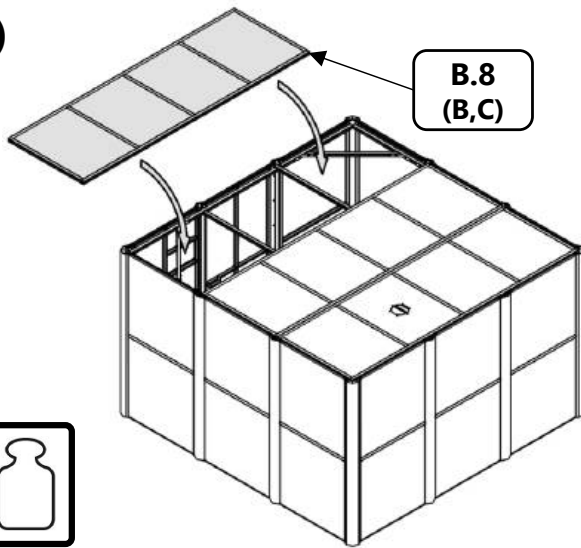

B.25 (B,C)

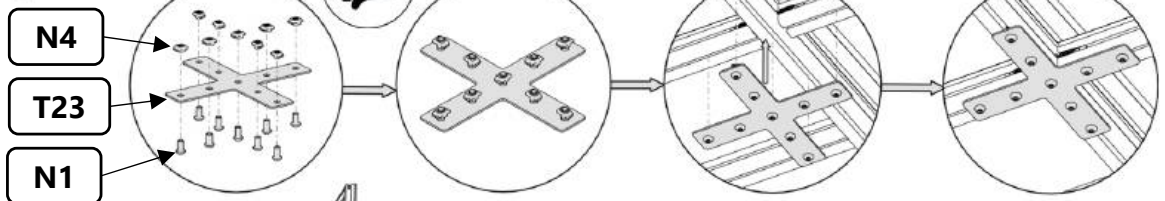

B: x4

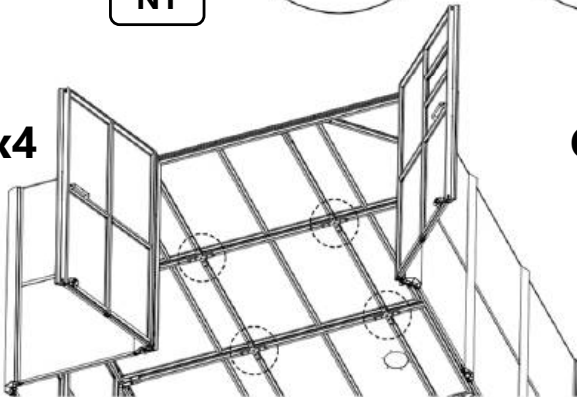

C: x6

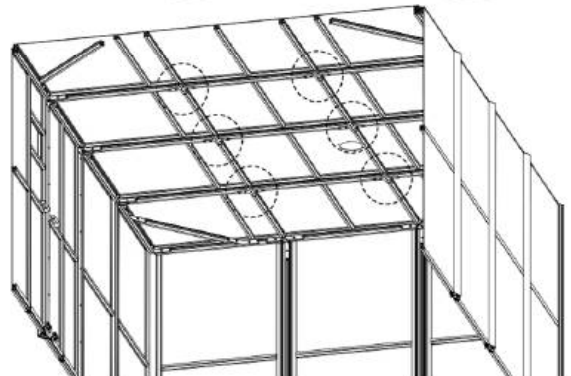

B.26 (B,C)

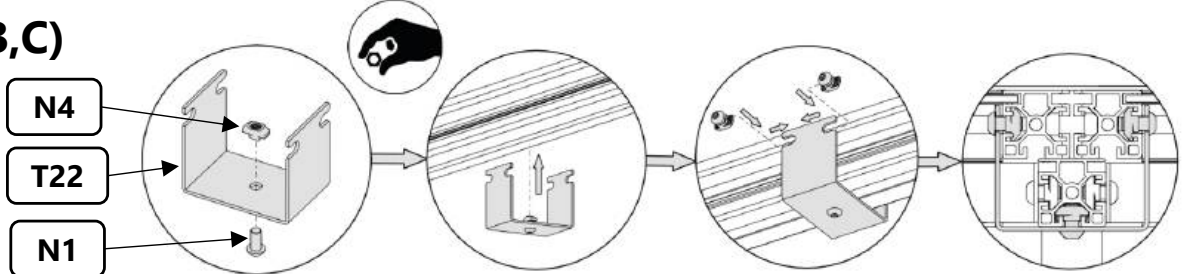

B: x12

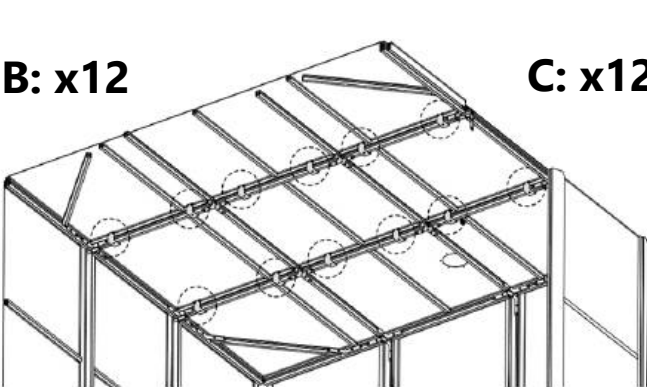

C: x12

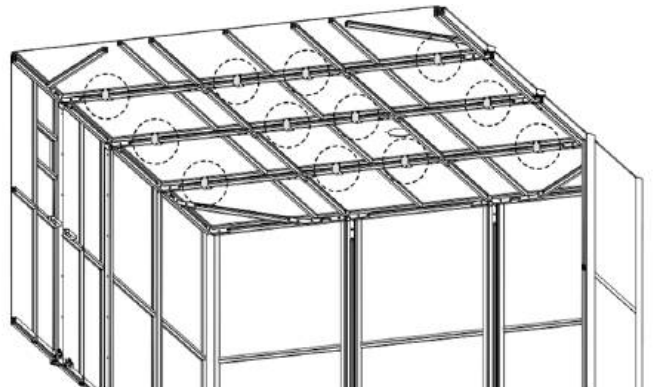

B.27 (B,C)

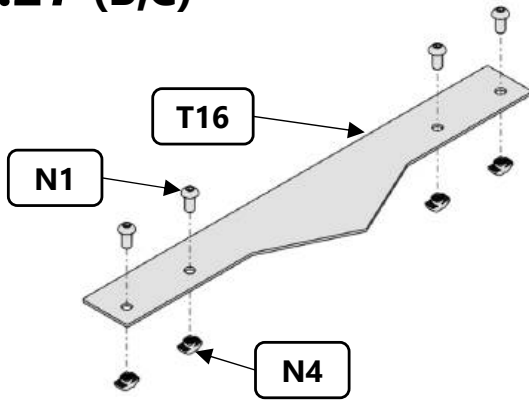

B: x6

C: x8



B.28 (B,C)

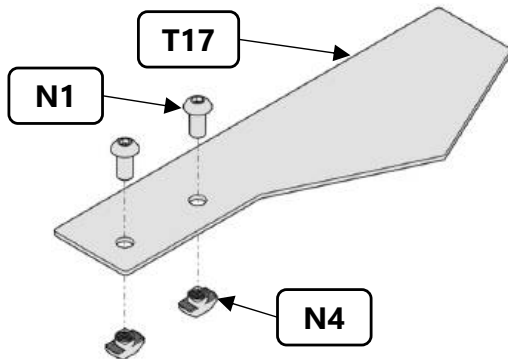

B: x1

C: x1



B.29 (B,C)

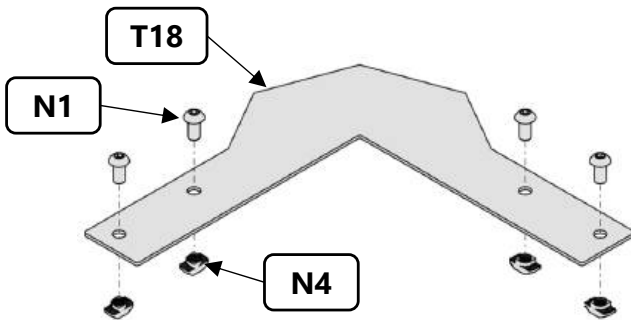

B: x3

C: x3



B.30 (B,C)

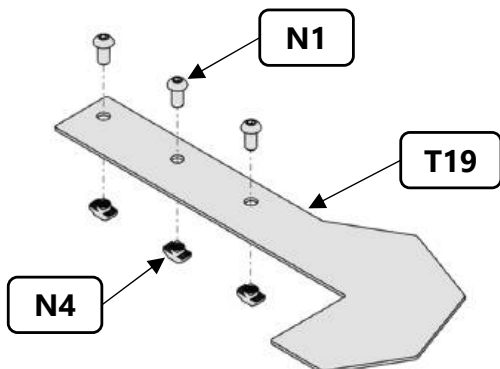

B: x1

C: x1



B.31 (B)

5

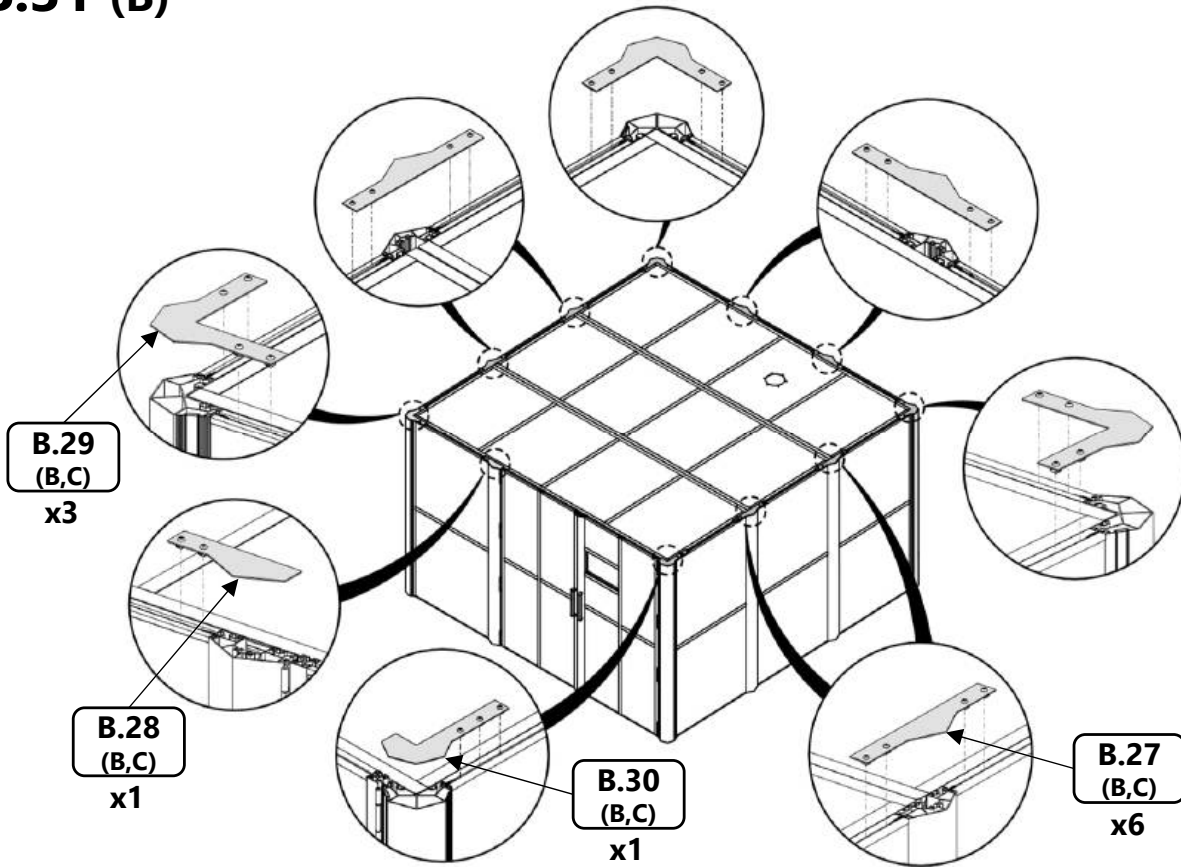

B.31 (C)

5

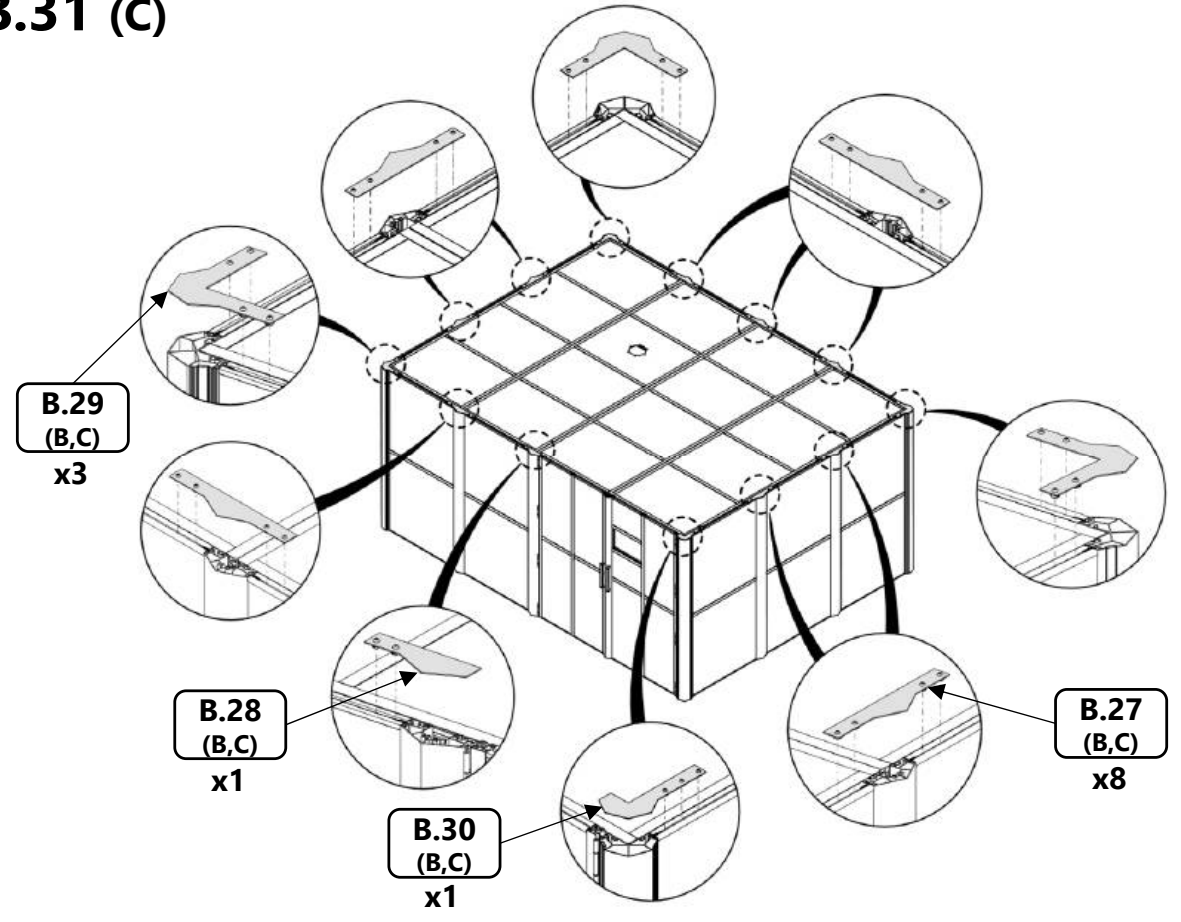

B.32 (B,C)

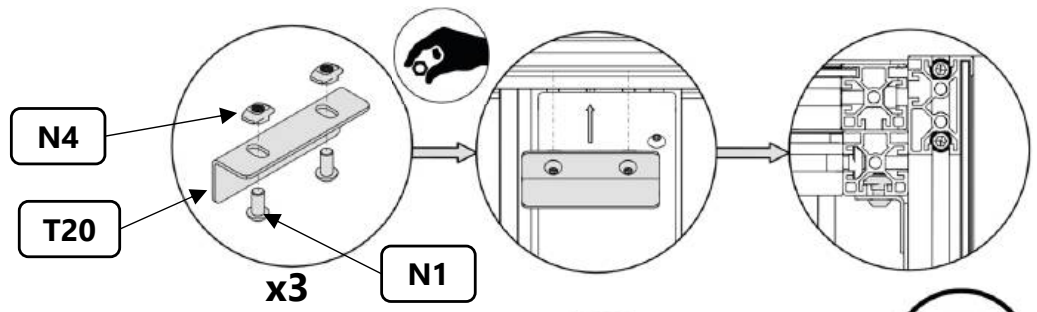

B

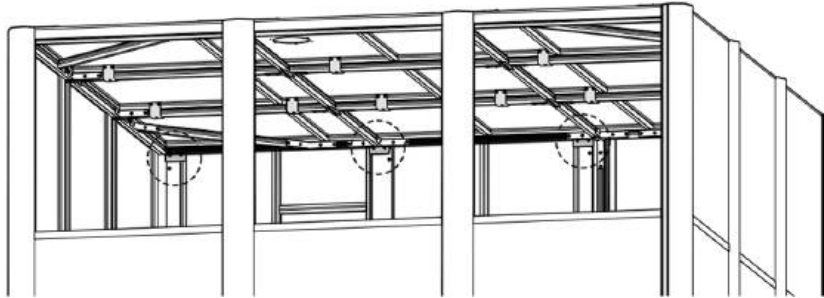

C

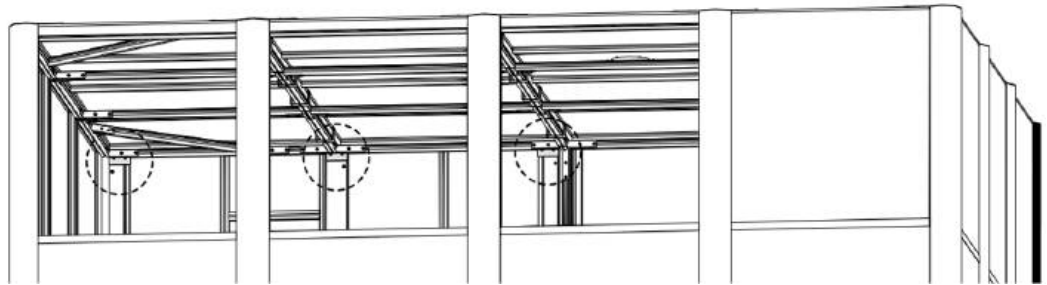

B.33 (C)

nur/only 4800x3600

C: x18

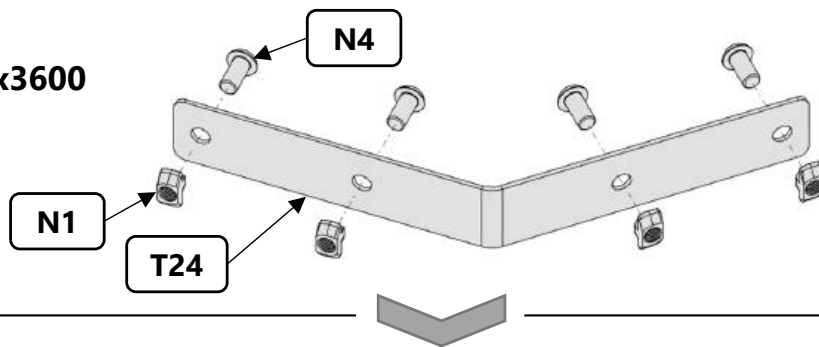

C: x9

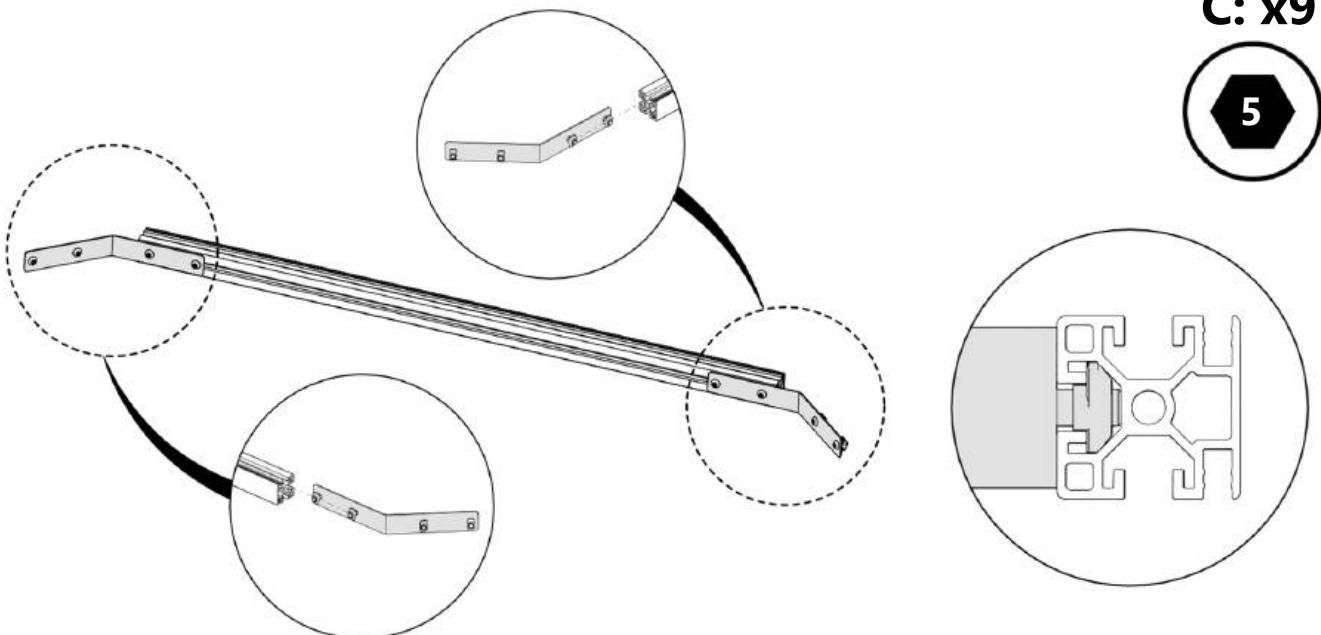

B.34 (C)

nur/only 4800x3600



B.33
(C)
x9

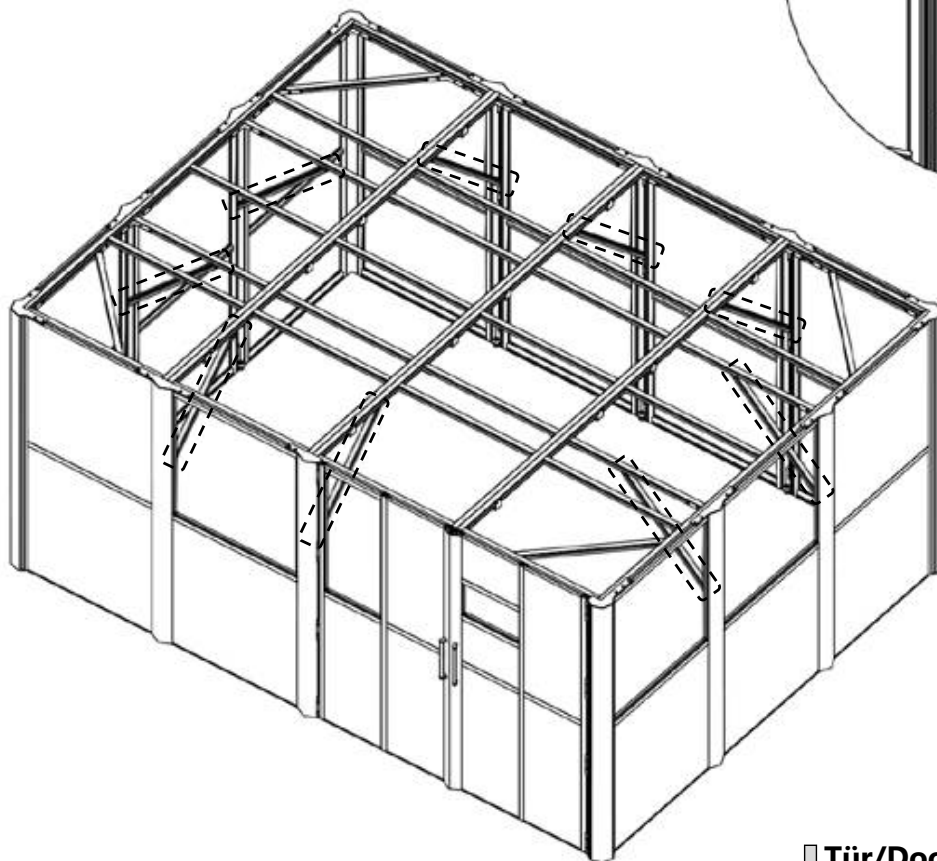
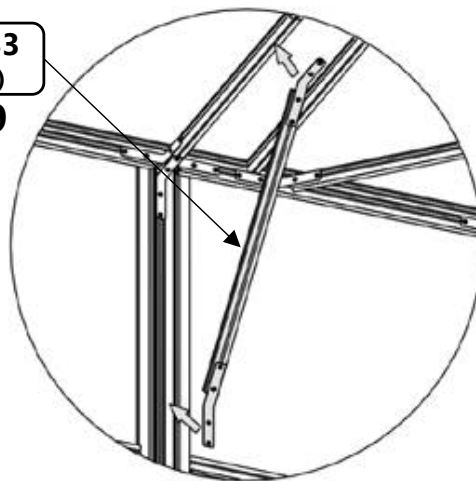

Tür/Door

