

siegmund

Laserschweißzelle · Laser welding cell

**A: 2400x2400x2250 - B: 3600x3600x2250 -
C: 4800x3600x2250**

Montageanleitung · Assembly instructions

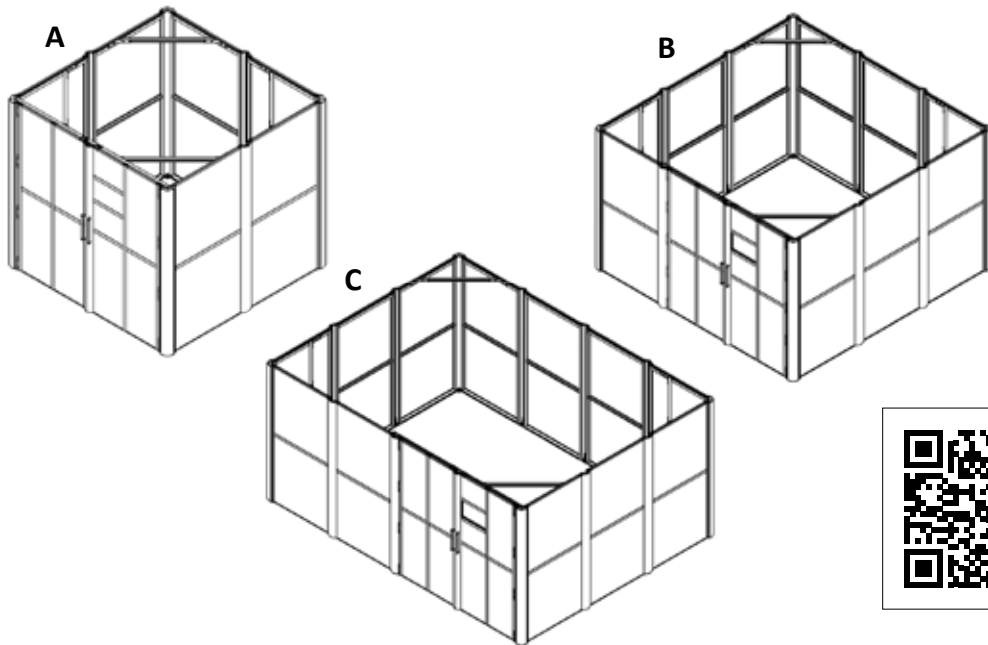

Mit Schraub Schlüssel festziehen · Tighten by wrench · Затягнете с гаечен ключ · Utáhněte pomocí klíče · Stram med nøgle · Pingutata vōtmeġa · Apertado con llave · Kiristä jakoavaimella · Serrer avec une clé · Σφίξιμο με κλειδί · Zategnuti ključem · Kulccsal feszítse meg · Serrare con chiave · Priveržkite veržliarakčiū · Aandraaien met een sleutel · Stram til med fastnøkkel · Przykręć kluczem · Aperto com chave · Strângeți cu o cheie · Zategnuti ključem · Затянуть ключом · Spänn åt med skiftnyckel · Priviti s ključem · Utiahnite klúčom · Anahtarla sıkmak













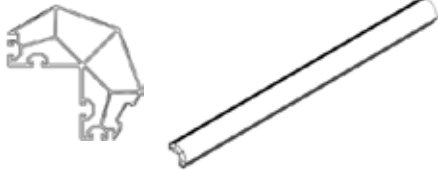



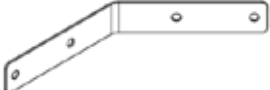

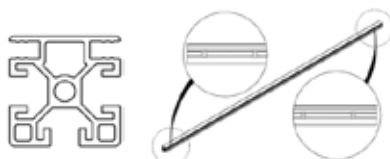



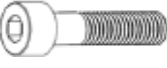

Handfest - Bitte nicht festziehen · Hand-screwed - please do not tighten · Ръчно завинтване - моля, не затягайте с помощен инструмент · Ručně zašroubováno - prosím nedotahujte · Håndskruet - stram venligst ikke · Käsitsi kinnitatav ärge kinnitage jõuga · Enroscado a mano - no apretar · Käsikireys - ei saa kiristää työkalulla · Serré à la main - Ne pas serrer · Βιδώστε με το χέρι - παρακαλούμε μην σφίγγετε · Ručno zategnuti - ne prejako · Kézi rögzítés - ne húzza meg erősen · Avvitare a mano - non serrare forte · Rankinis prisukamas - prašome neužveržkite · Aandraaien met de hand - niet te vast aandraaien · Hånd skrudd, ikke stram til · Przykręć ręcznie - proszę nie dokręcać · Aperto manual - por favor não force o aperto · Înşurubat manual - vă rugăm să nu strângeți · Ručno zavrnuti - molimo vas da ne pretežete · Завинчивать вручную - не затягивать · Handskruvad - spänn inte åt · Ročno priviti - prosim ne zategujte · Ručné naskrutkovanie - prosím, neúfahujte silou · El vidalı - lütfen sıkmayın

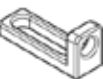
Bernd Siegmund GmbH

Landsberger Straße 180 | 86507 Oberottmarshausen | Germany (Bavaria) | Phone 0049 (0) 82 03 / 96 07 - 0 | Fax 0049 (0) 82 03 / 96 07 - 33
info@siegmund.com | www.siegmund.com

All texts, pictures and design elements are copyrighted by the Bernd Siegmund GmbH. No part of this flyer may be edited analogously or digital or in another mode, may be multiplied or published out of the flyer without written approval of the legal owner. Offences are prosecuted.

ART. NR.	OVERVIEW	NAME	QTY	ERP (anodized black)
T1		B-Profil 1030 / B-profile 1030	A: 12 B: 20 C: 24	00003836 (00004544)
T2		C-Profil / C-profile 1030	A: 10 B: 14 C: 16	00005247 (00005331)
T3		A-Profil / A-profile 2250	4	00004069 (00005322)
T4		E-Profil / E-profile 2250	A: 3 B: 7 C: 9	00005274 (00005321)
T5		Platte / Plate 1112x1050x4	A: 12 B: 20 C: 24	00005784
T6		Sichtschutzblech / visual protection sheet 2205	2	00005335
T7		Haltblech für Verstellereinheit / Holding plate for adjustment foot	A: 2 B: 3 C: 3	00005391
T8		Winkelblech 45° / Angled sheet metal 45°	8	00005338
T9		Clipsprofil LED / Clip profile for LED	4	00004090
T10		C-Profil mit Bohrungen / C-shape profile with holes A: 2390mm B,C: 2480mm	1	A: 00005560 (00005561) B,C: 00005365 (00005366)

ART. NR.	OVERVIEW	NAME	QTY	ERP
N1		Gewindeformverbinder / Thread forming connector	A: 72 B: 100 C: 120	00003998
N2		Schraube / screw ISO 7380 M8x16	50	00003962
N3		Hammermutter Nut / hammer nut 10 M8	A: 60 B: 68 C: 72	00005357
N4		Zylinderschraube / Socket head screw ISO 4762 M8x35	A: 2 B: 3 C: 3	00003795
N5		Nutenstein / T-Slot Nut M8	A: 2 B: 3 C: 3	00003789
N6		Anschlag- und Spannwinkel Stop and clamping angle 90L	A: 5 B: 8 C: 10	16002646
N7		Montageschraube / Mounting bolt	A: 10 B: 16 C: 20	00002992
N8		Scheibe / Washer ISO 7089 - 10	A: 14 B: 22 C: 26	00002953
N9		Mutter / Hex nut ISO 4032 - M10	A: 14 B: 22 C: 26	00003346
N10		HVS-M10x50 - FT36x10	A: 7 B: 11 C: 13	00003345
N11		Dichtungsprofil / Sealing profile		00004117
N12		Keilprofil / Wedge profile		00006041

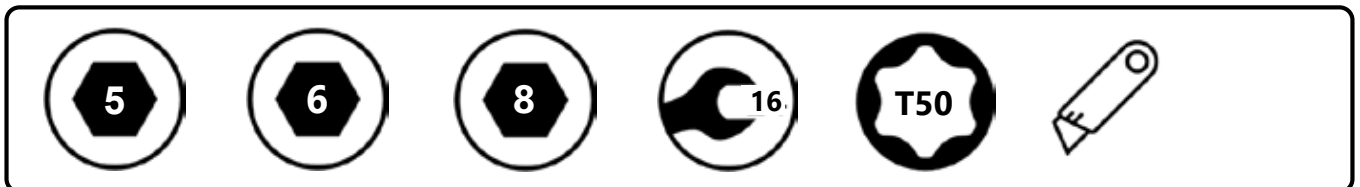

Option:

Vormontage /
pre-assembly

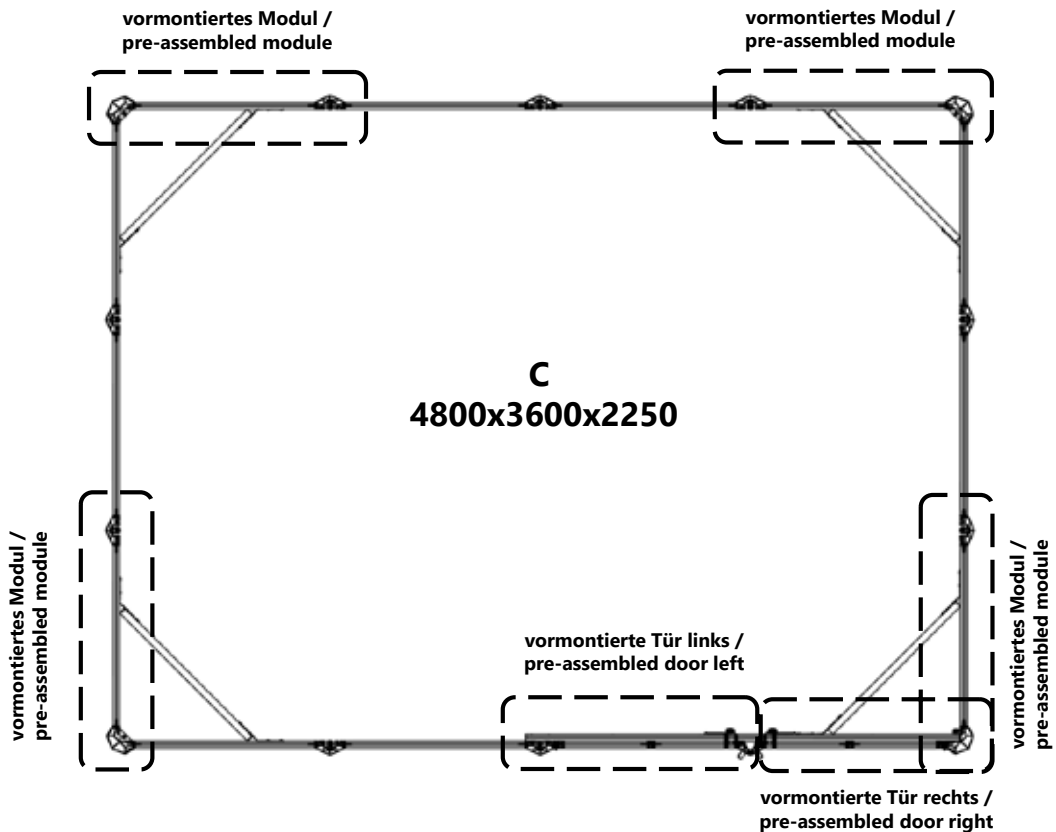
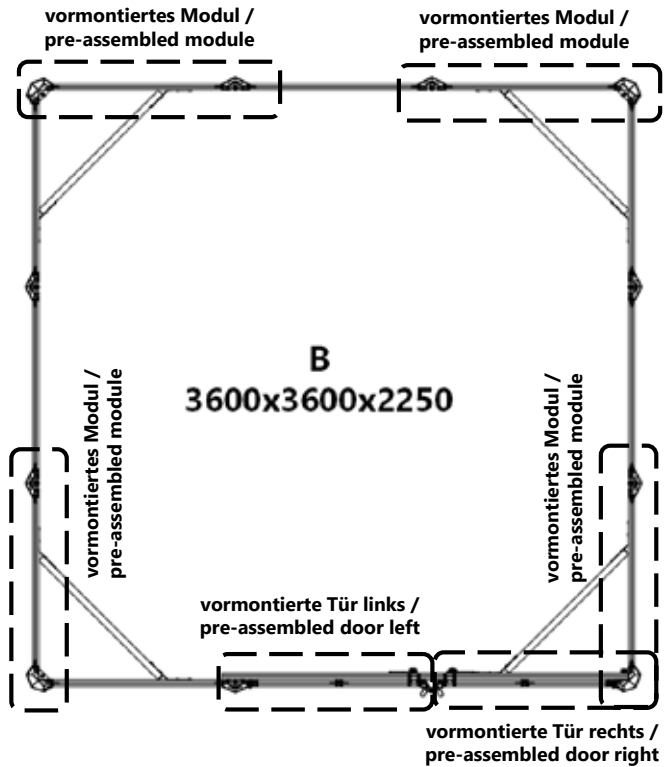
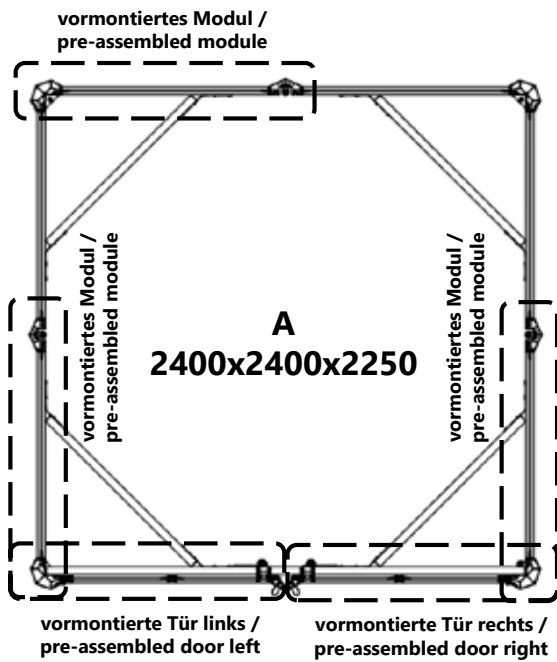

T1



x12/x20/x24

N1



x36/x60/x72



B.1-1

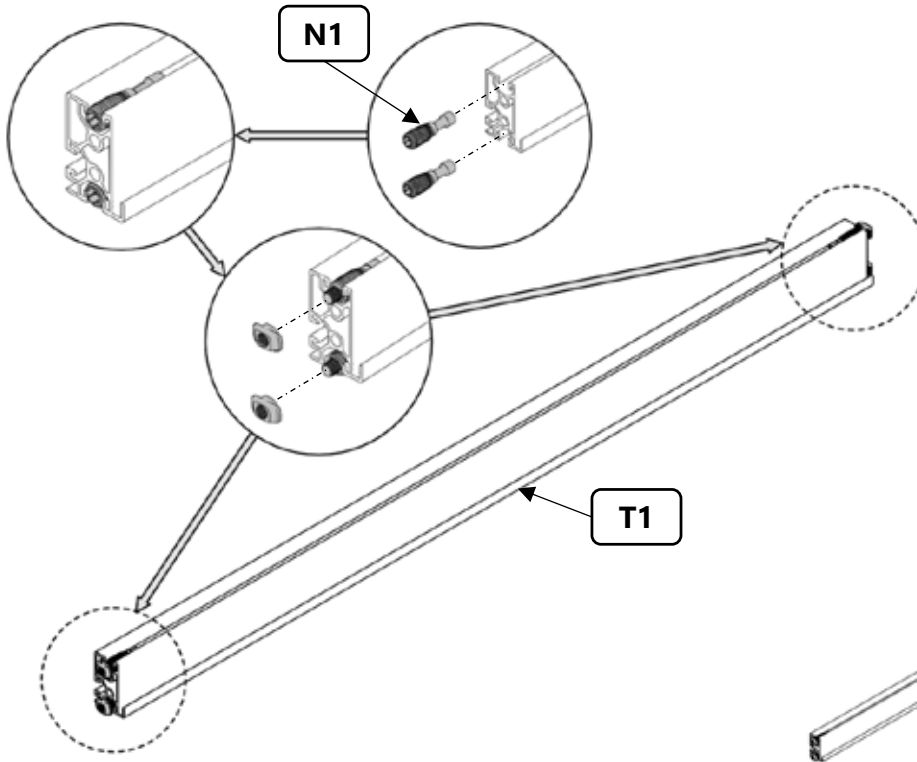

A: x6
B: x10
C: x12

B.1-2

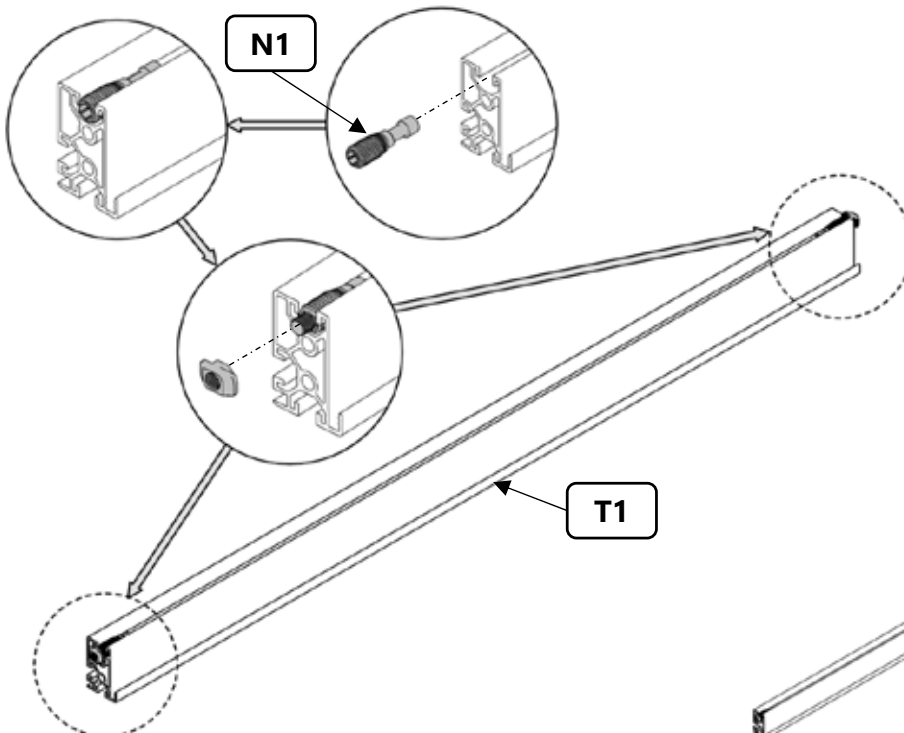

A: x6
B: x10
C: x12

T2



x6/x10/x12

N1



x24/x40/x48



B.2

A: x6
B: x10
C: x12

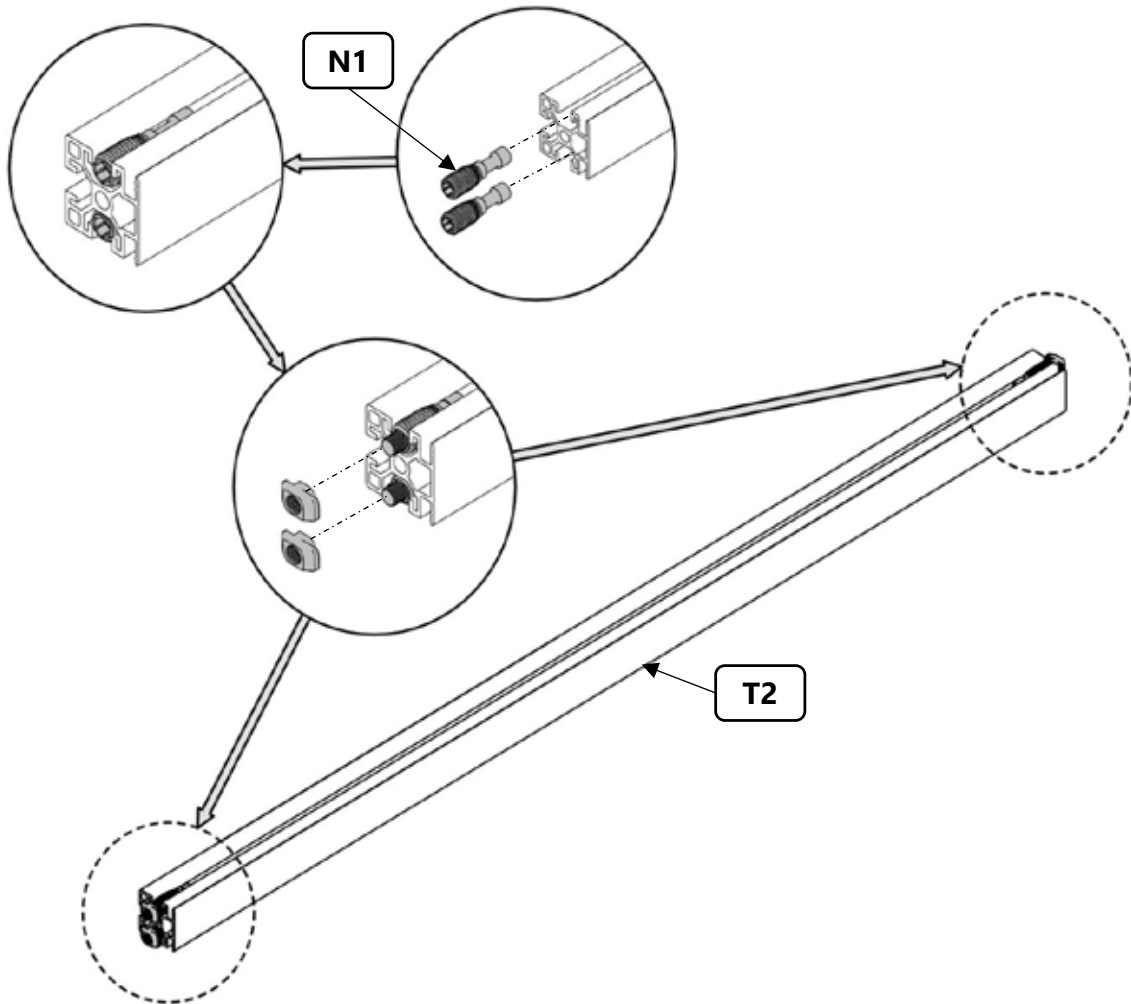
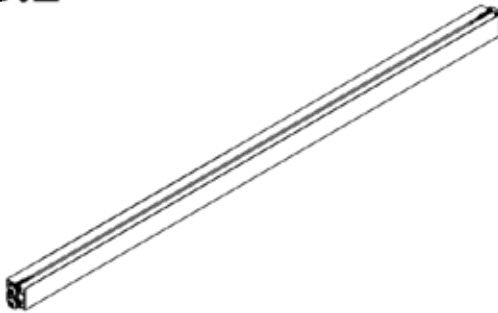

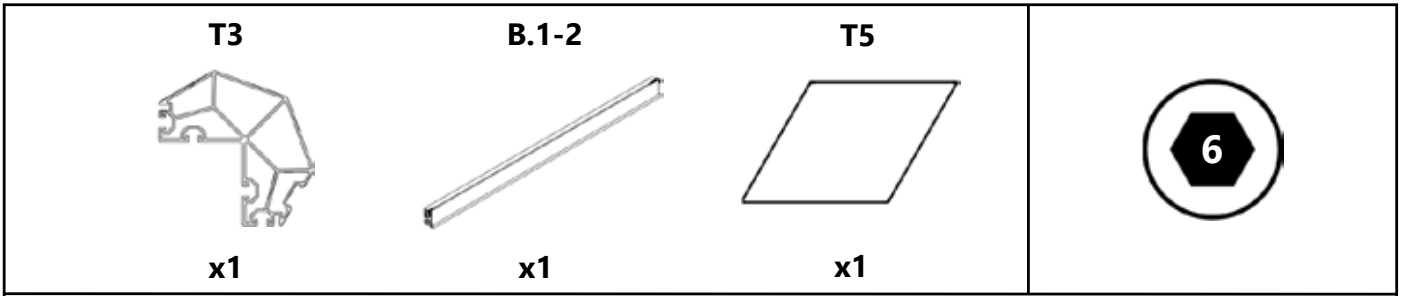

B.3

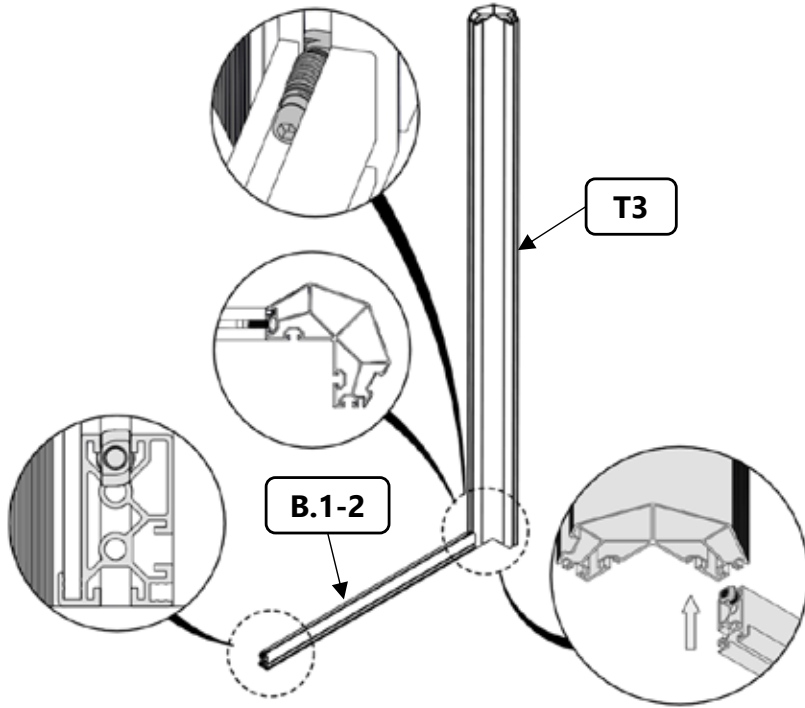

B.4

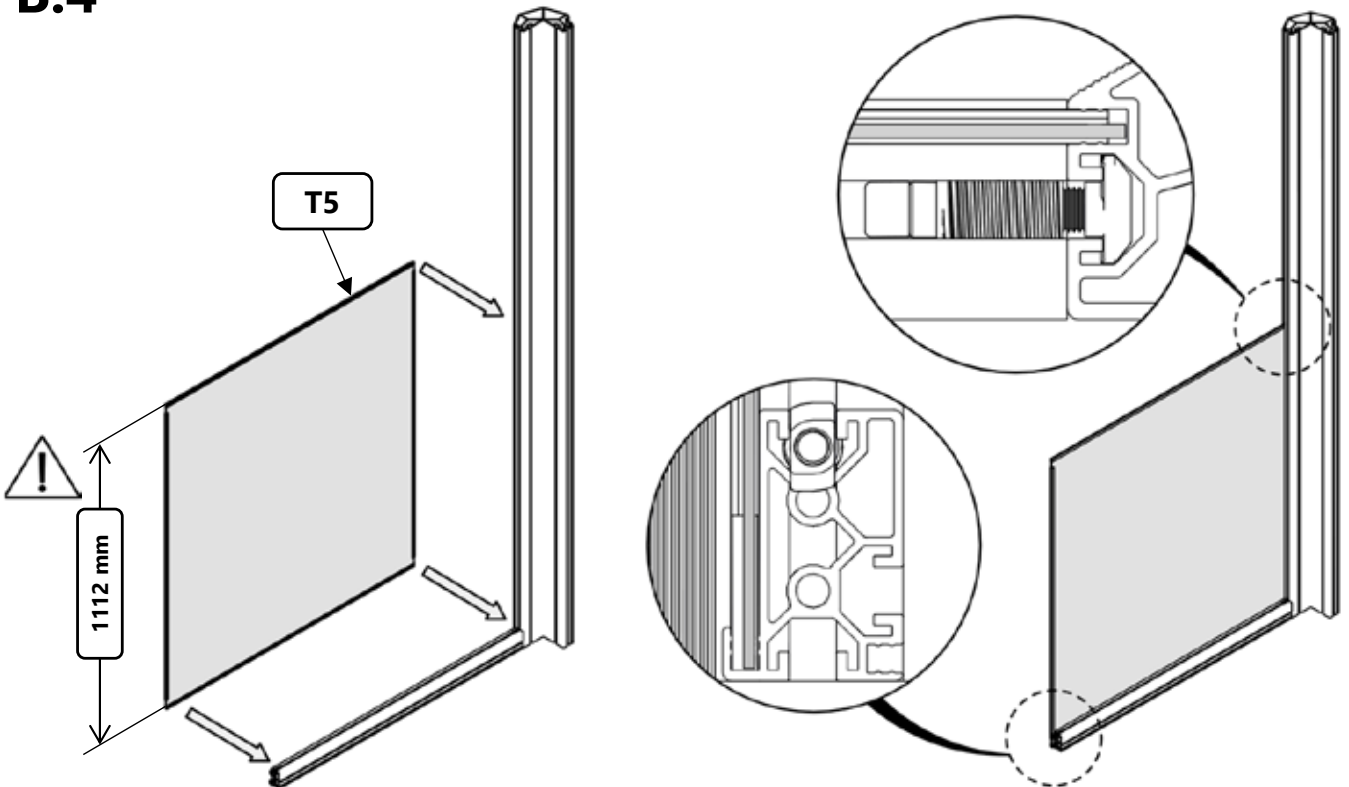

B.5

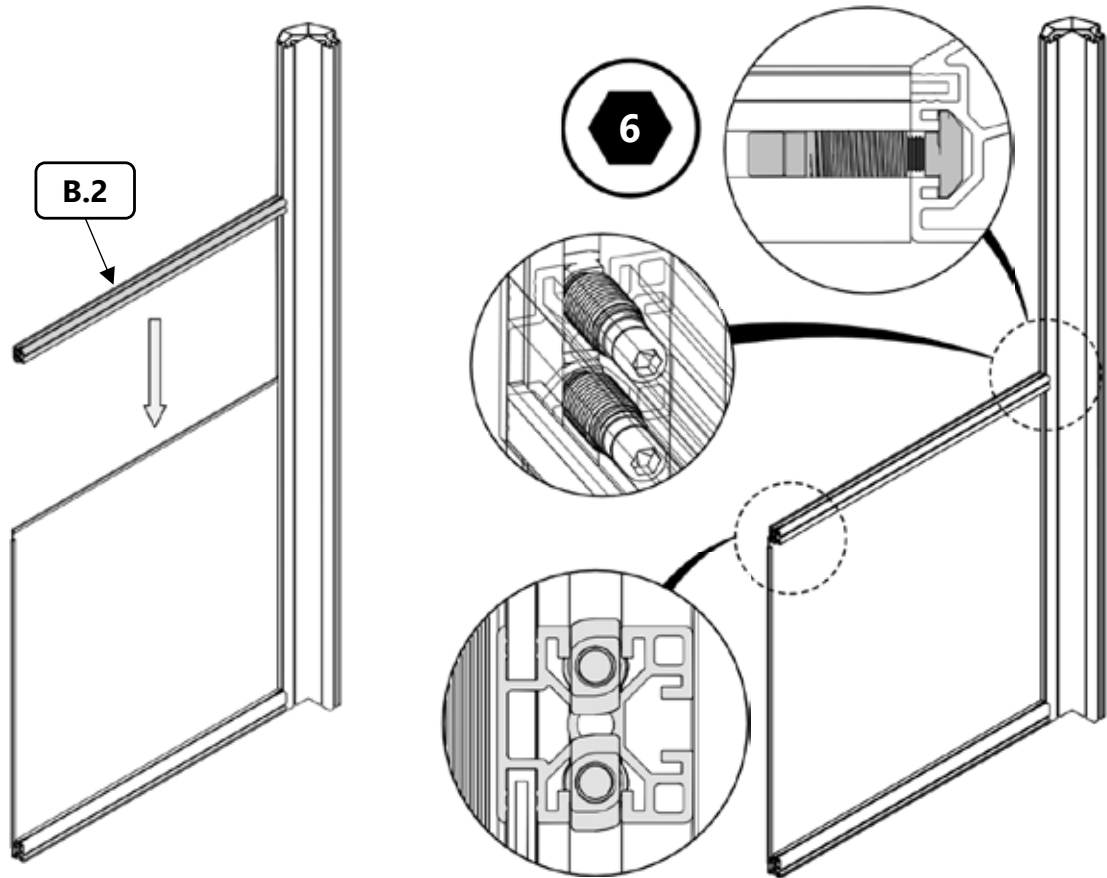

B.6

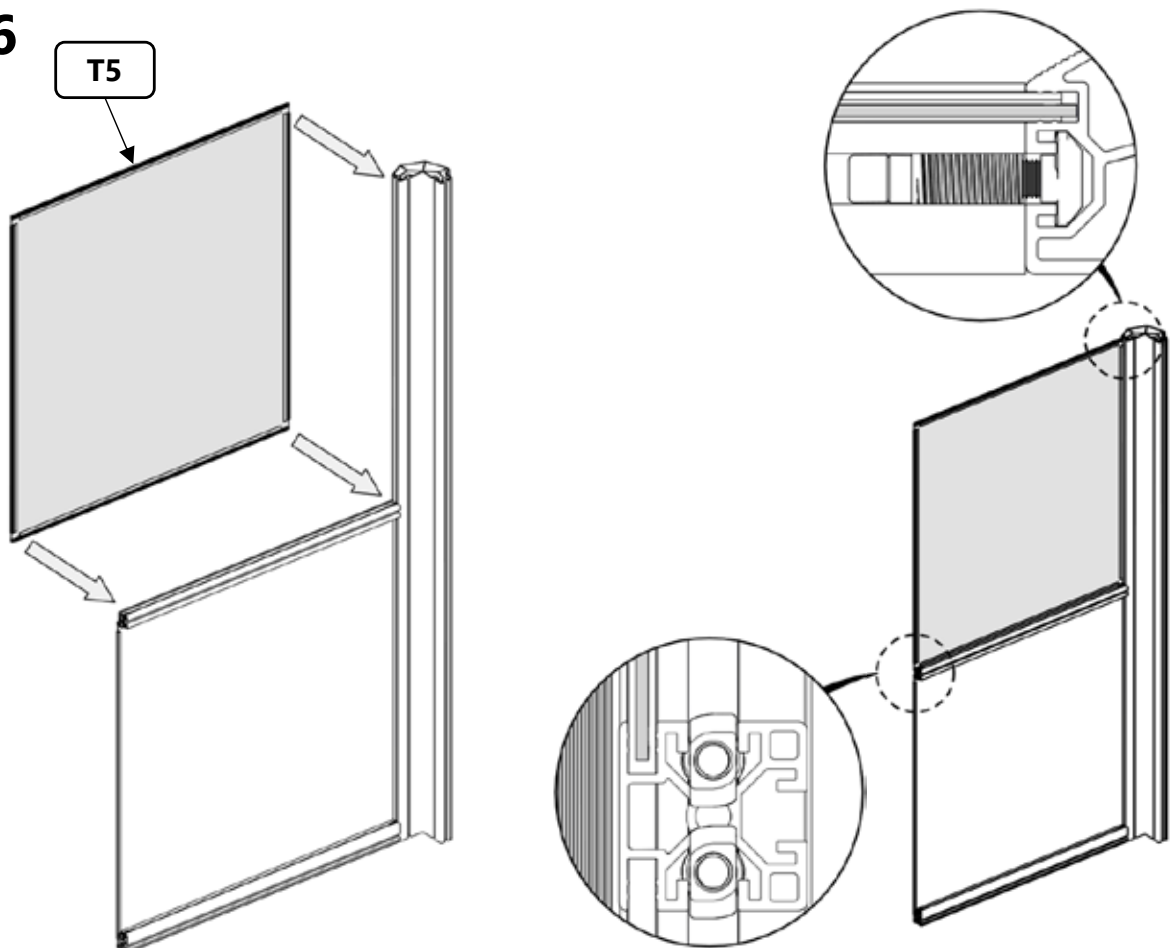

B.7

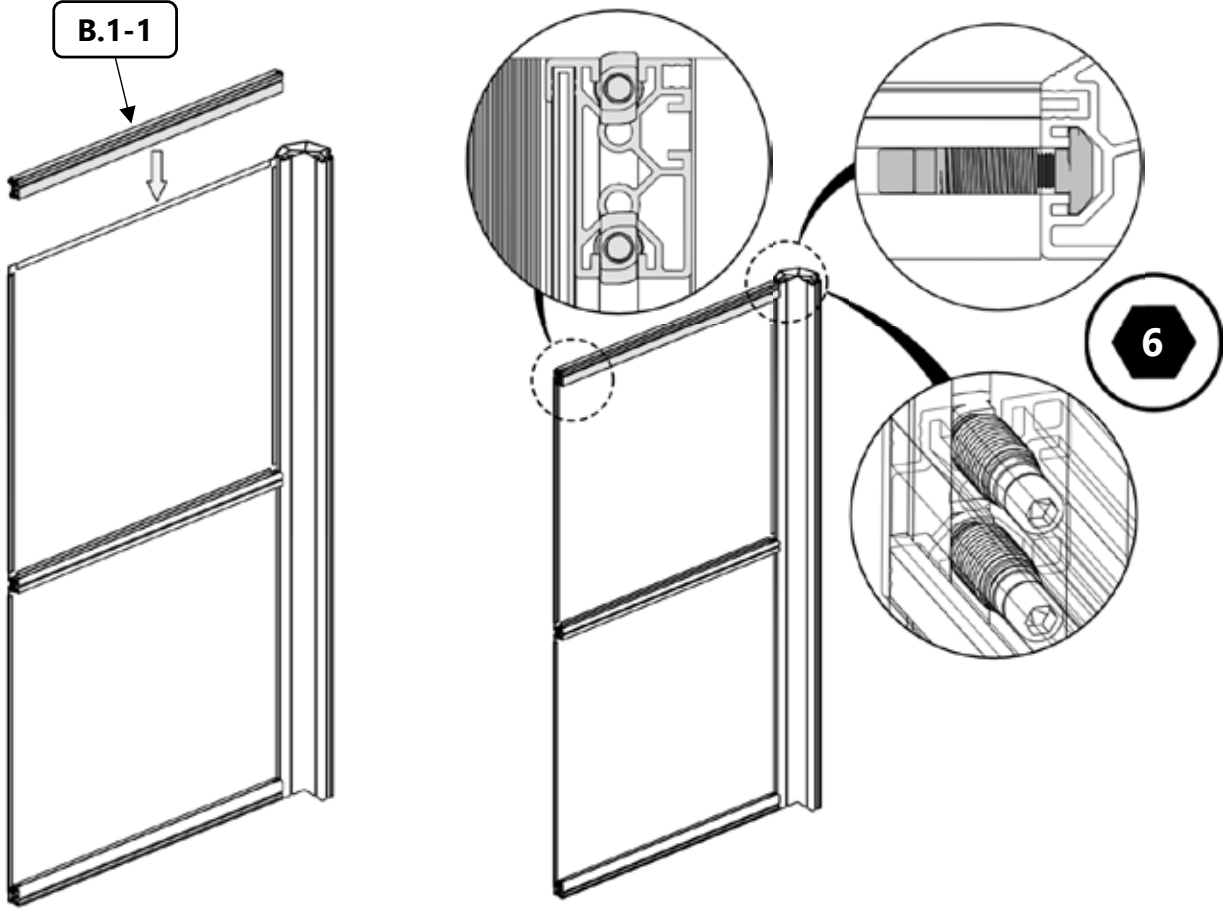

B.8

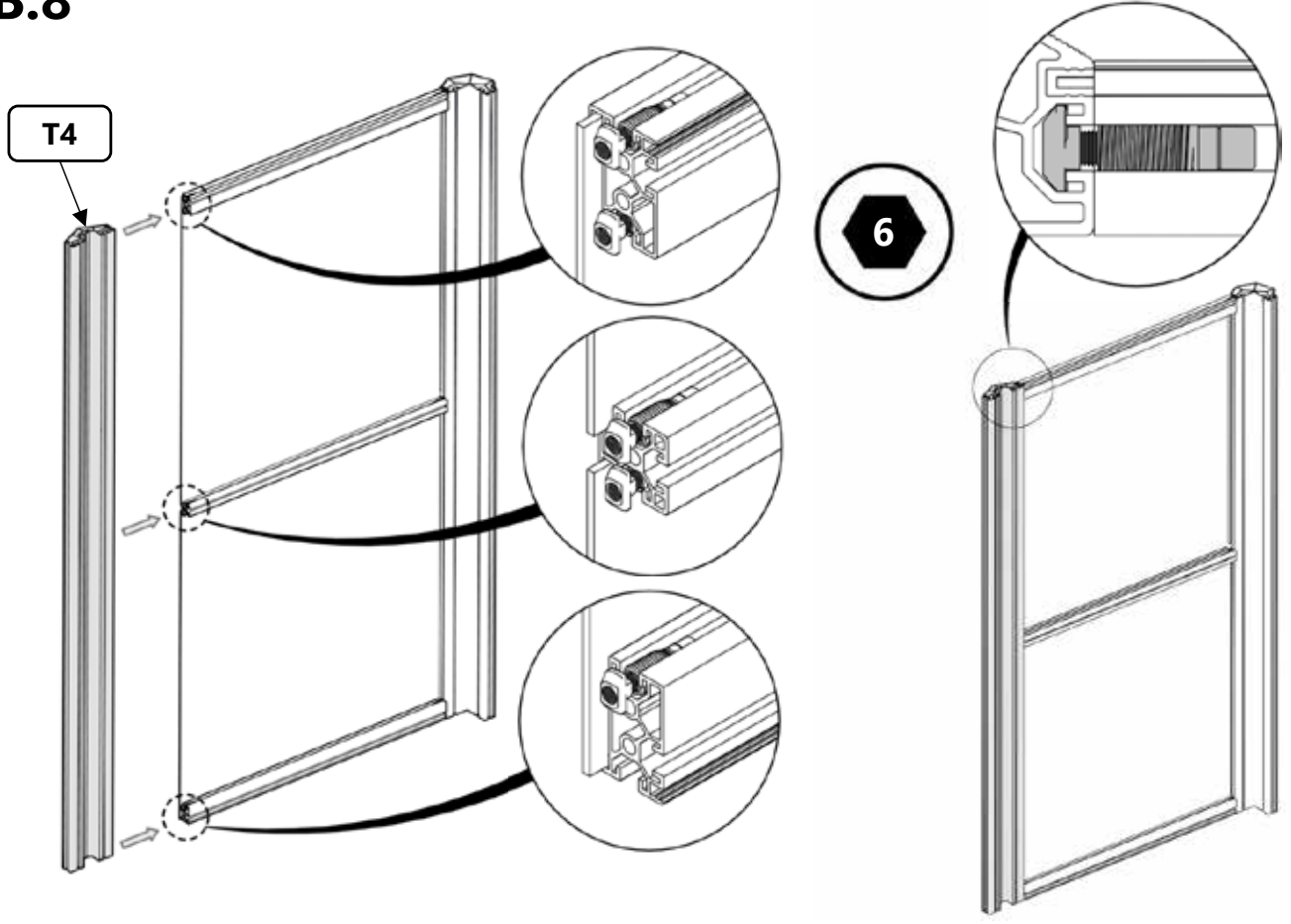

N12



B.9

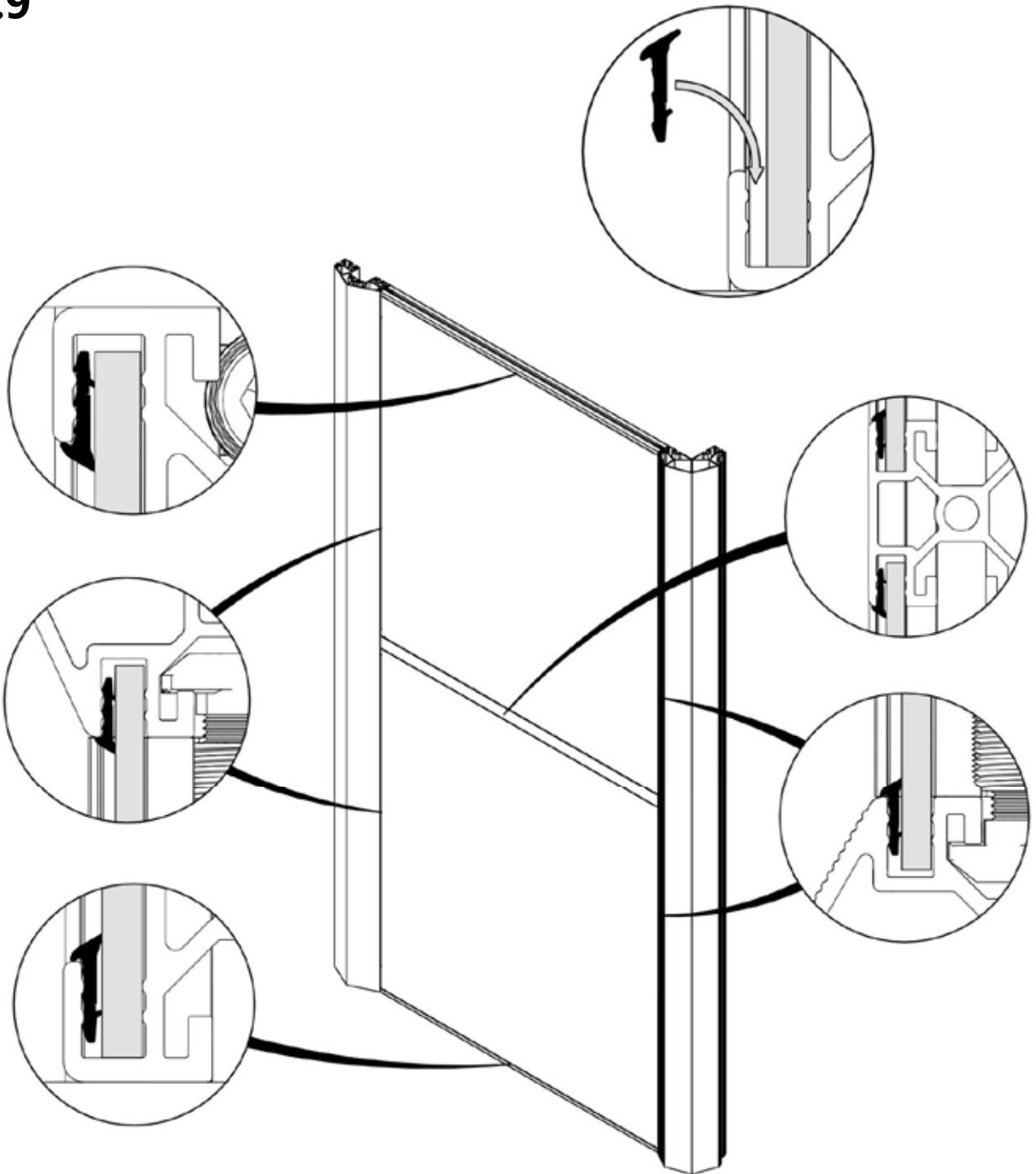

B.10 (A,B,C)

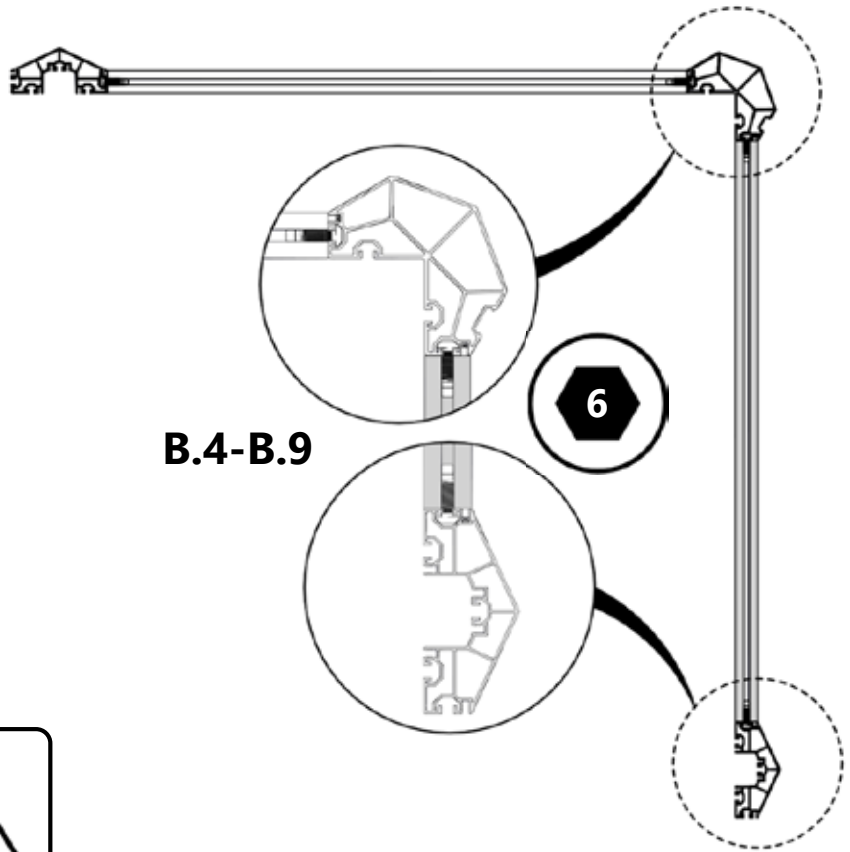
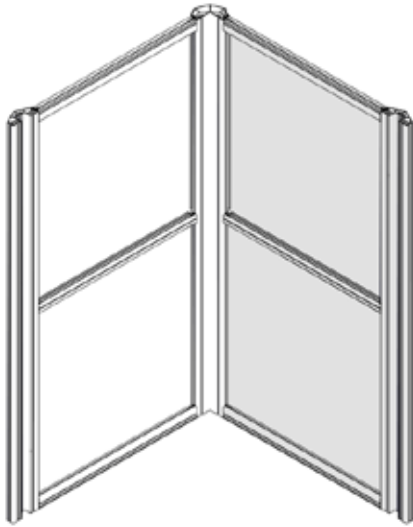

A: B.10 – B.14
B: B.10 – B.18-1
C: B.10 – B.18-2



B.11 (A,B,C)

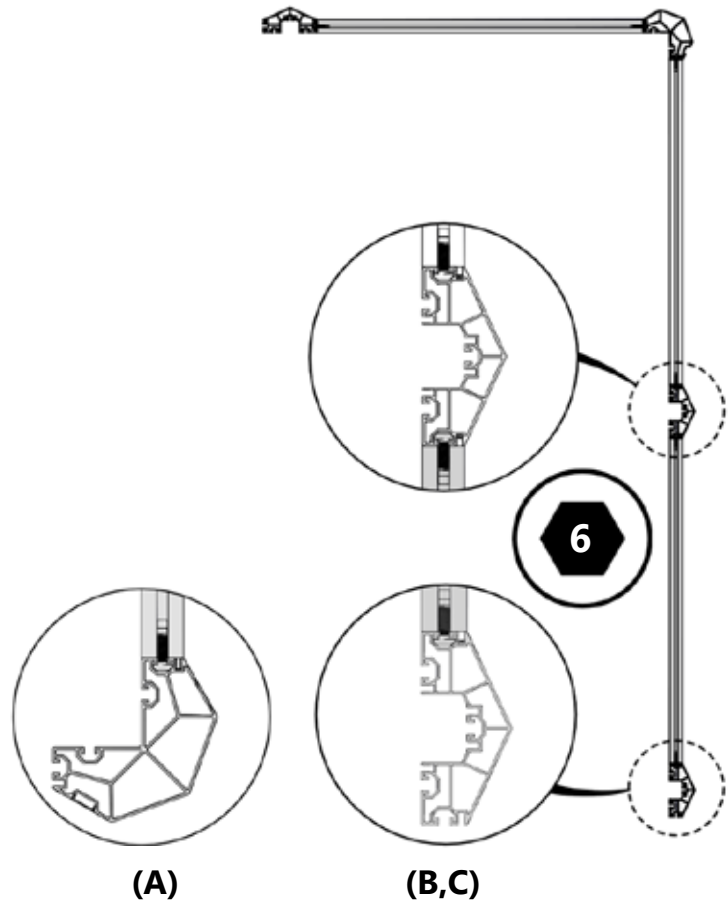
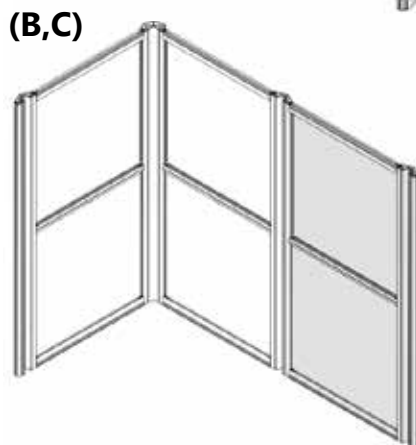
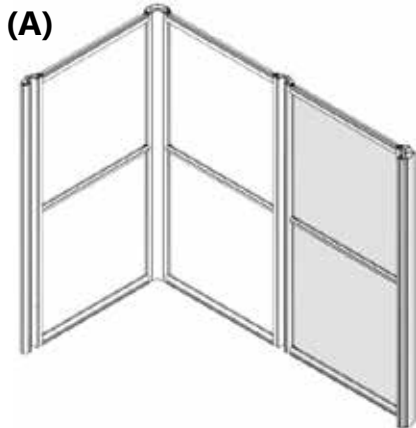

B.12 (A)

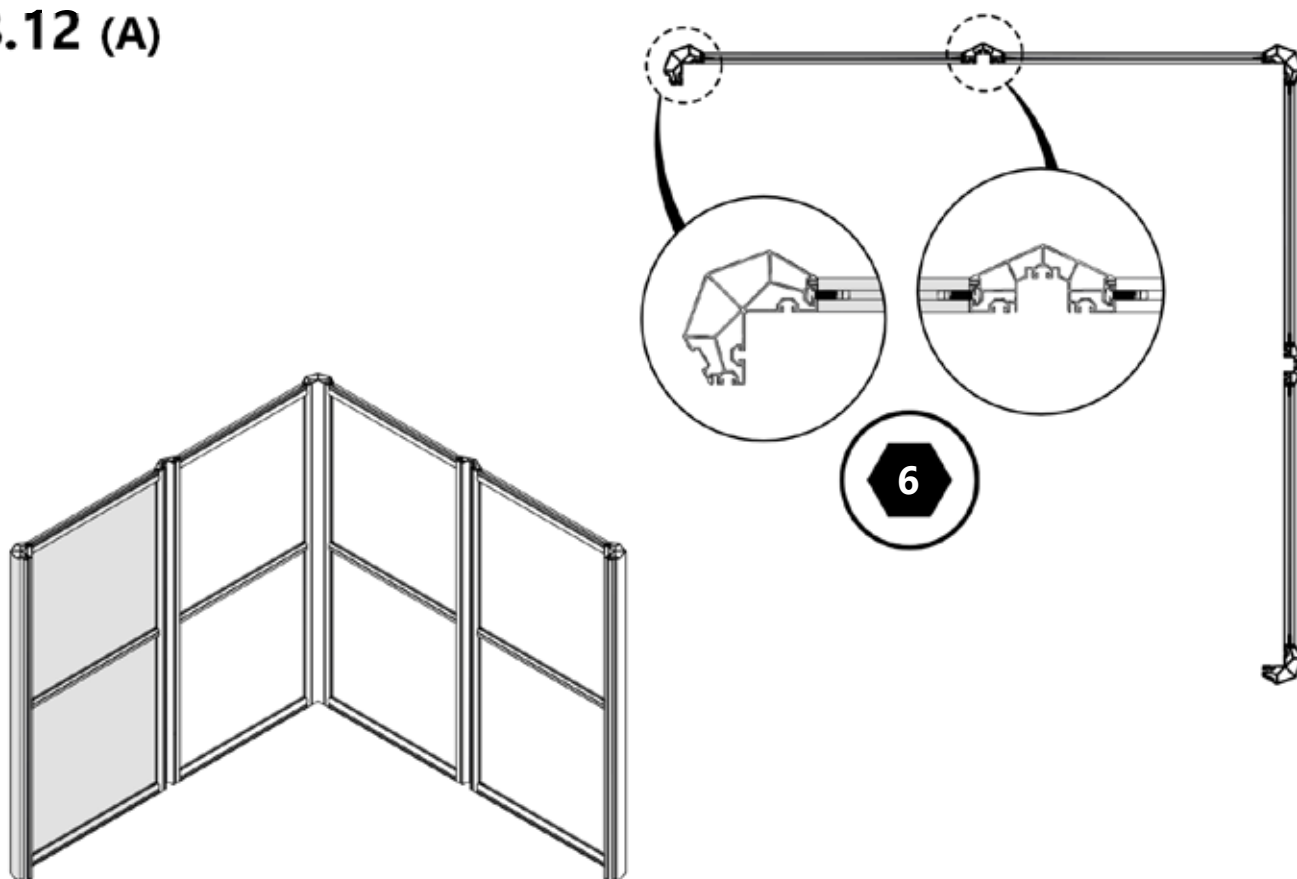

B.12 (B,C)

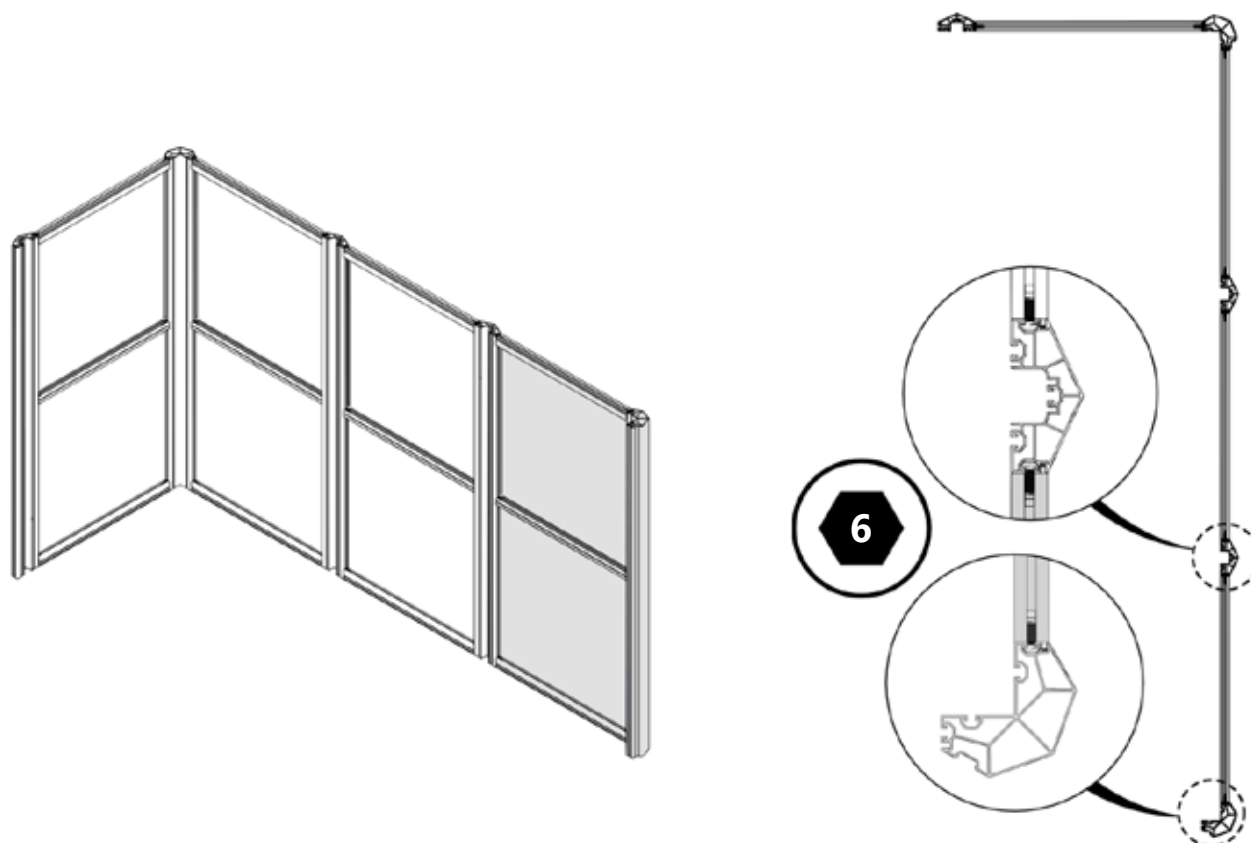

B.13 (A)

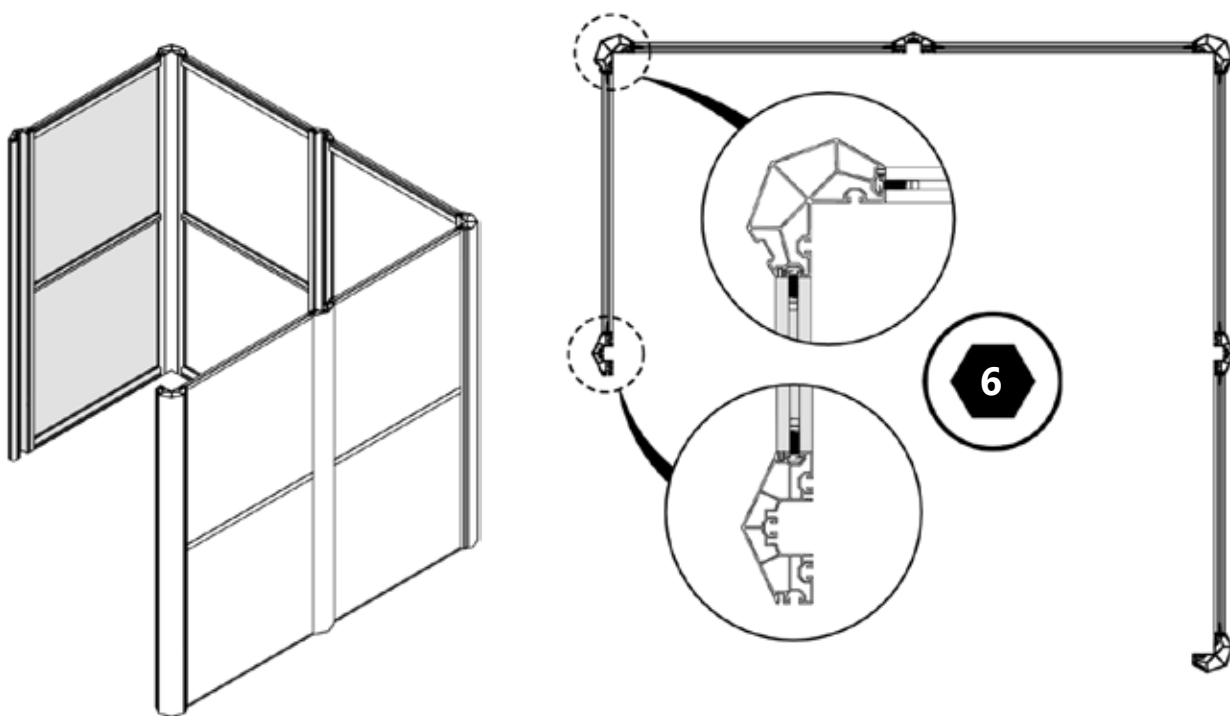

B.13-1 (B,C)

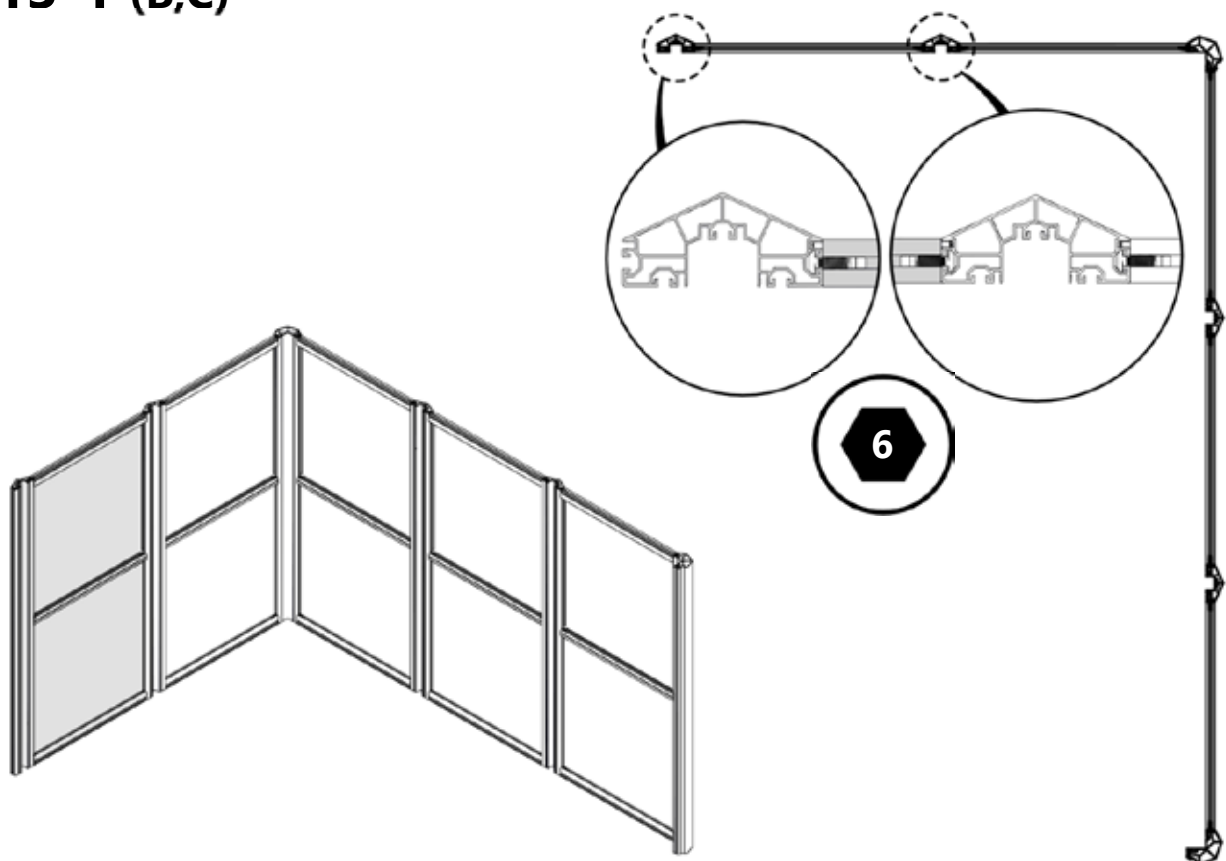

B.13-2 (C)

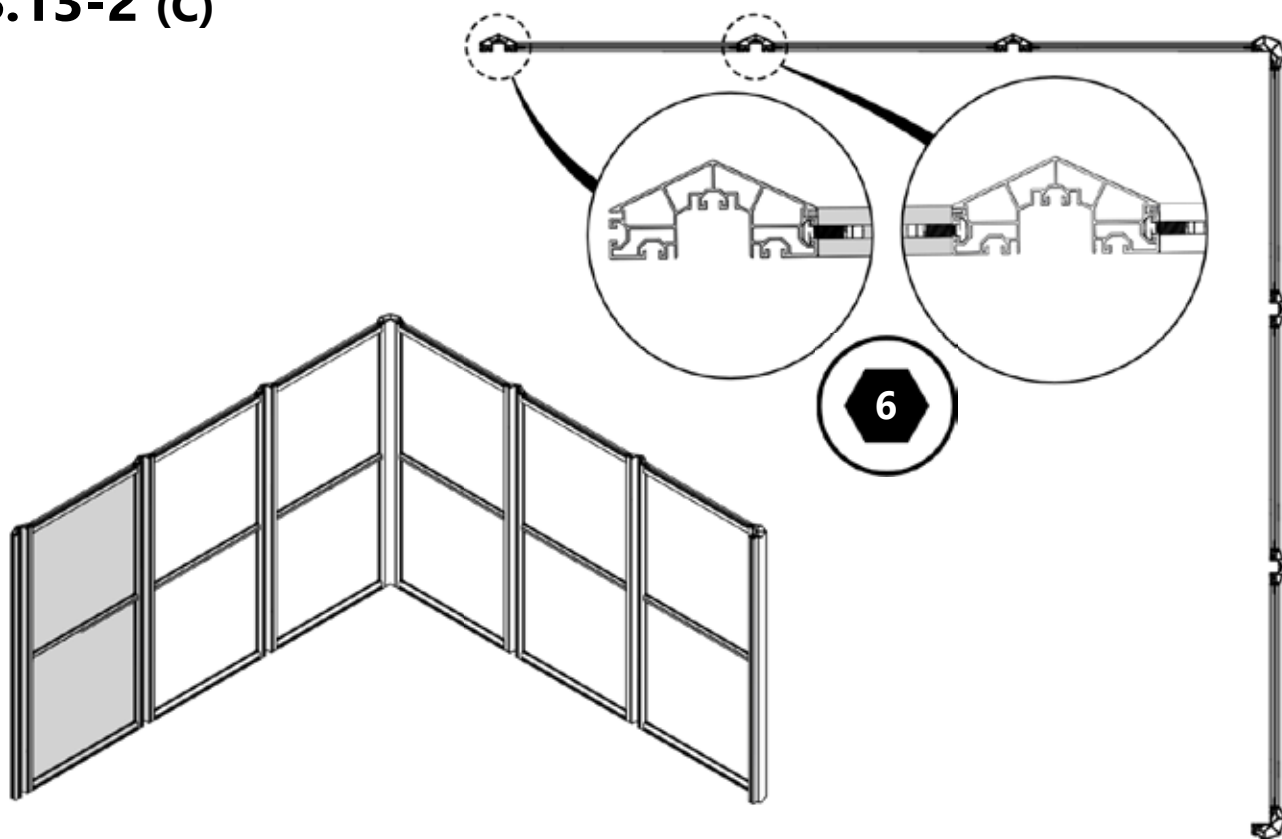

B.14 (A)

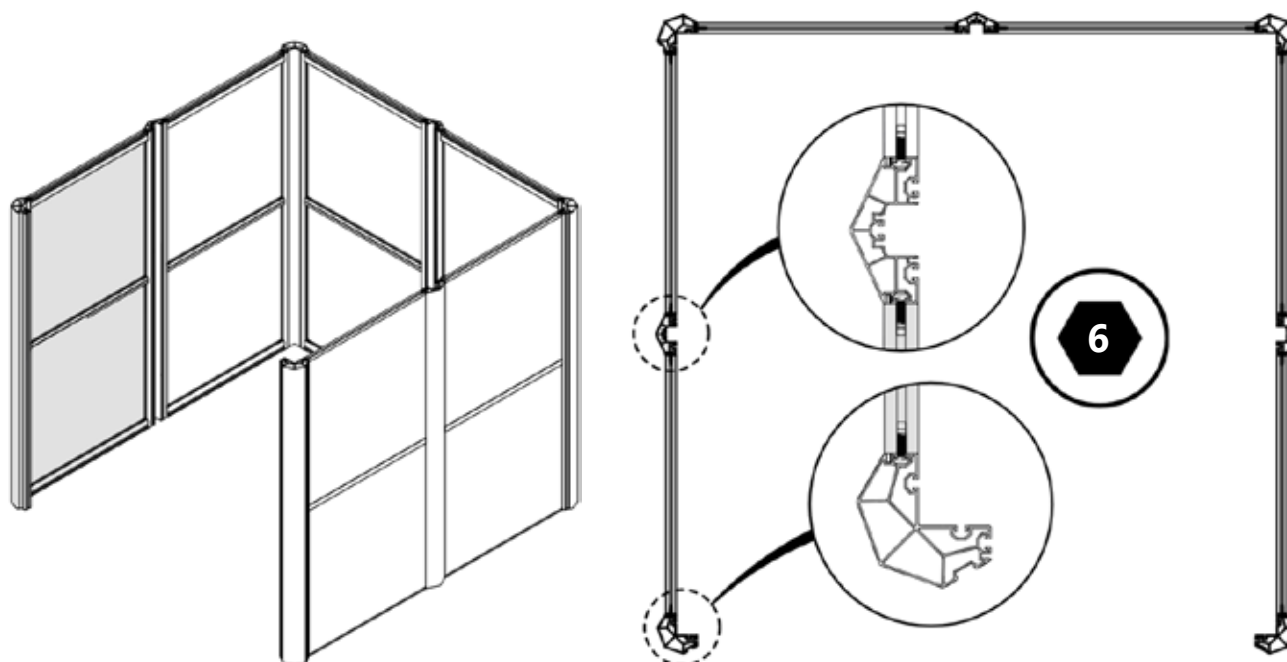

B.14 (B,C)

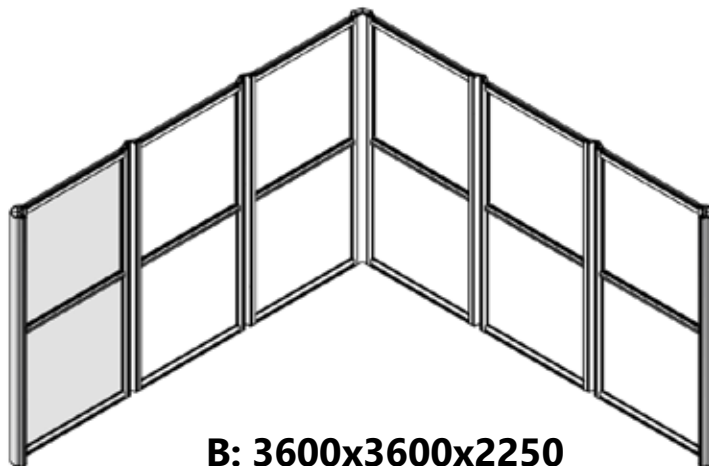
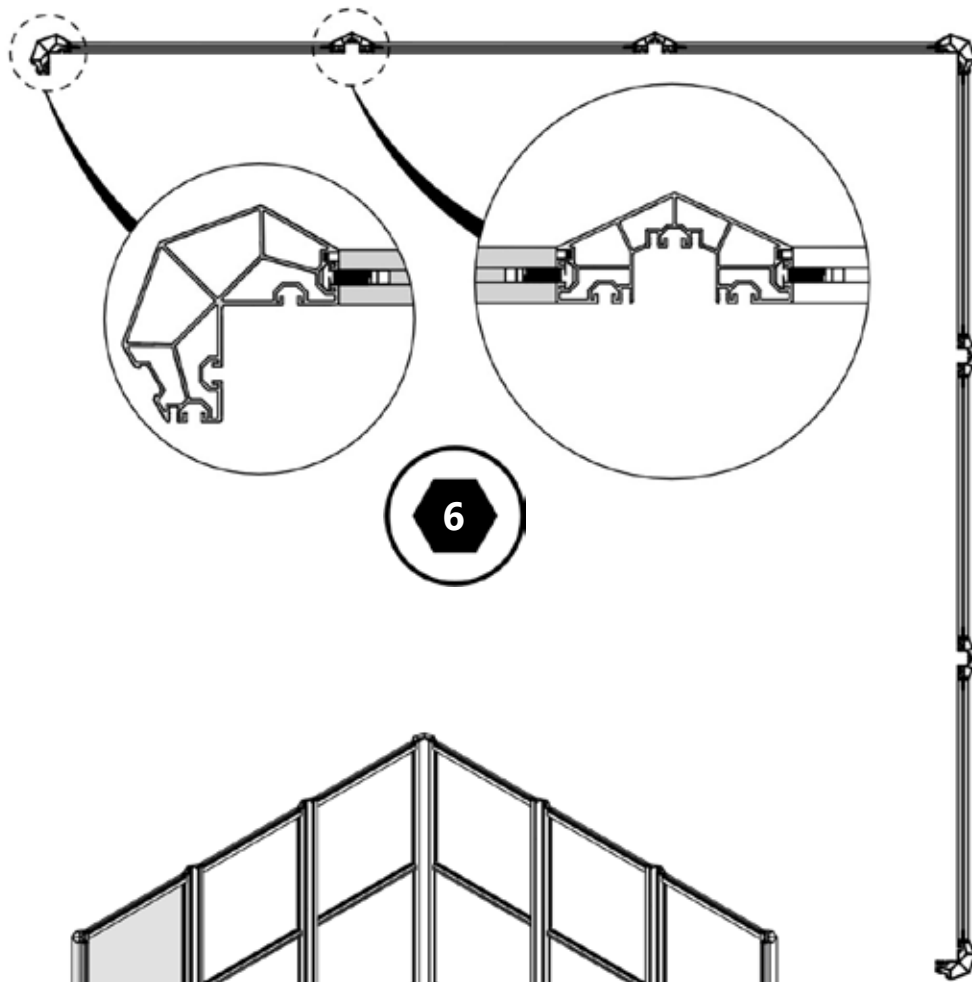

B: 3600x3600x2250

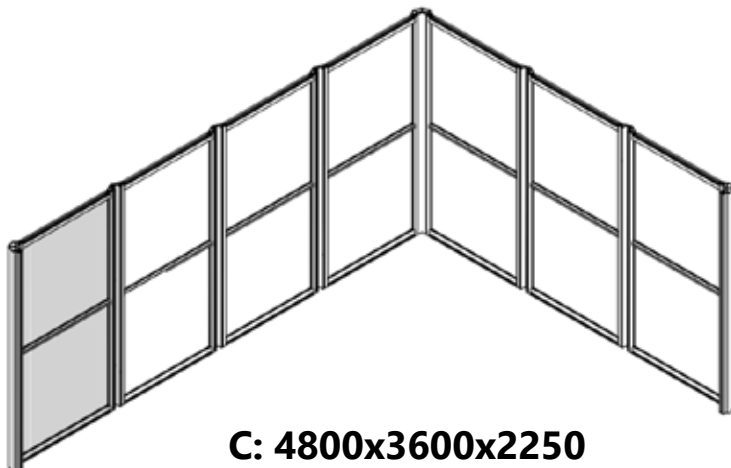

C: 4800x3600x2250

B.15 (B,C)

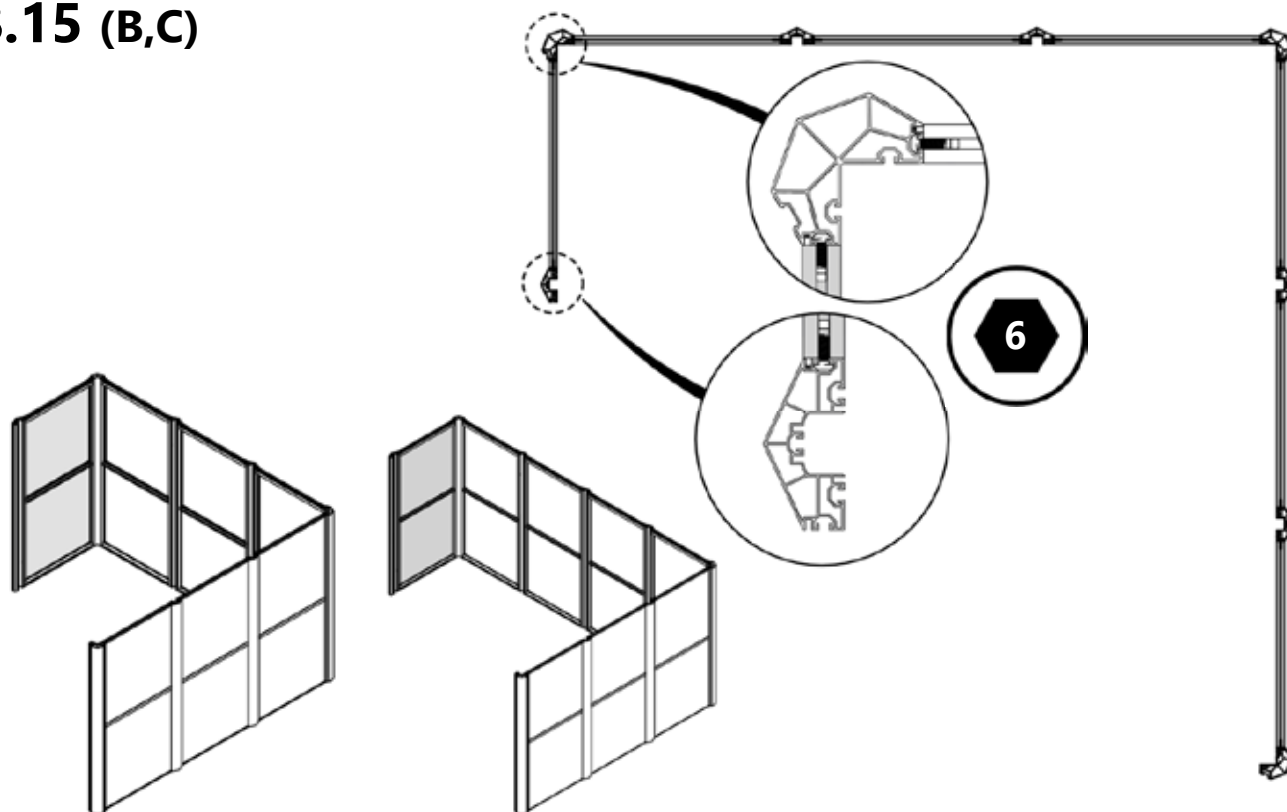

B: 3600x3600x2250

C: 4800x3600x2250

B.16 (B,C)

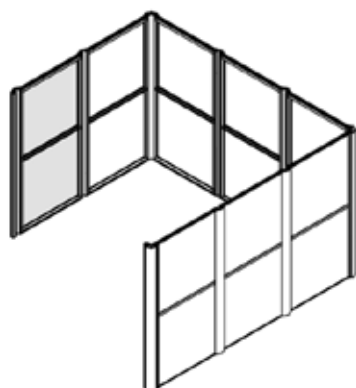

B: 3600x3600x2250

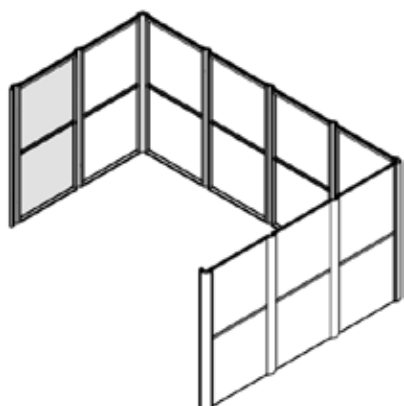

C: 4800x3600x2250

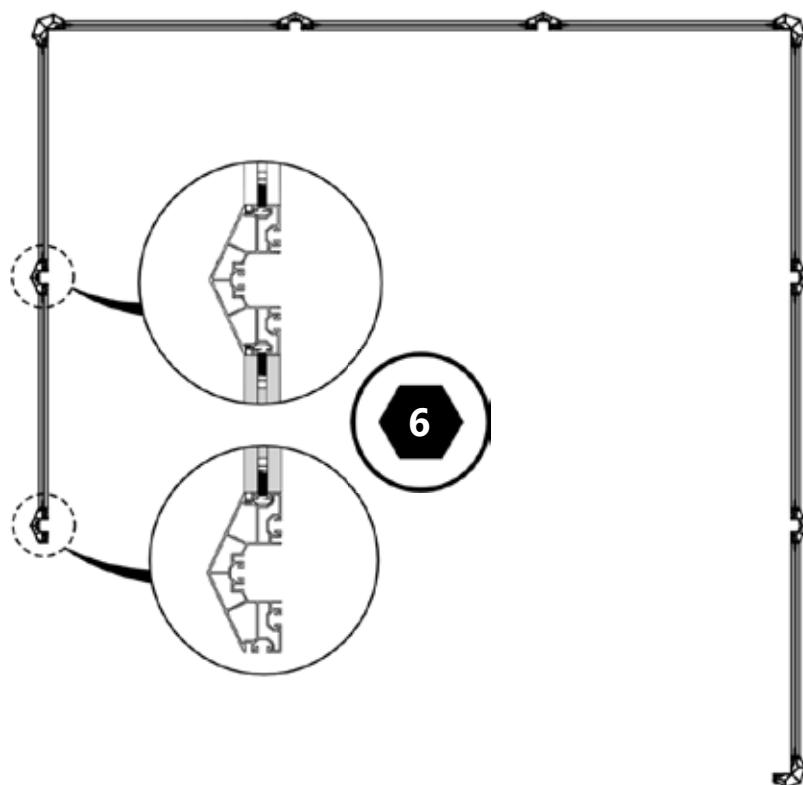

B.17 (B,C)

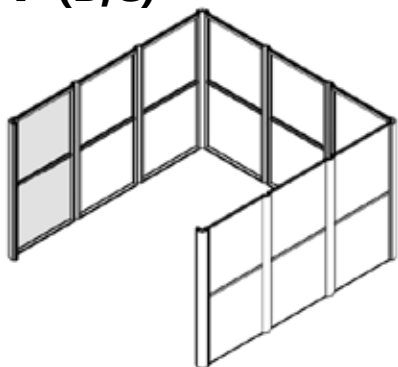

B: 3600x3600x2250

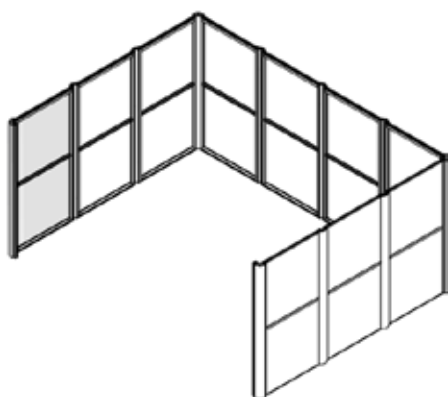

C: 4800x3600x2250

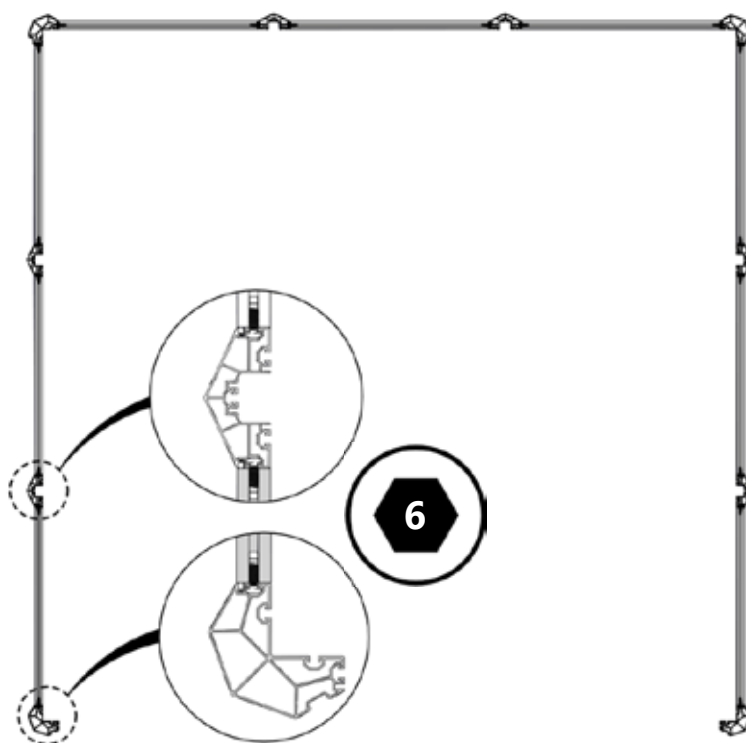

B.18-1 (B,C)

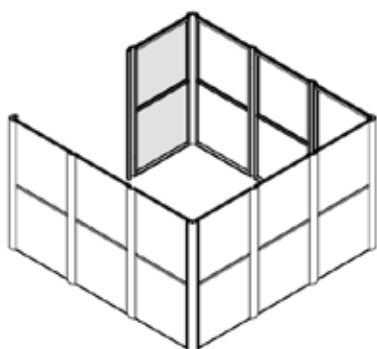

3600x3600x2250

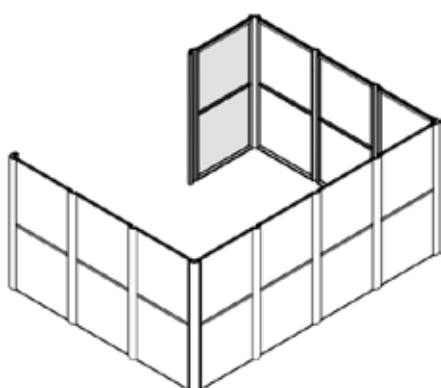

4800x3600x2250

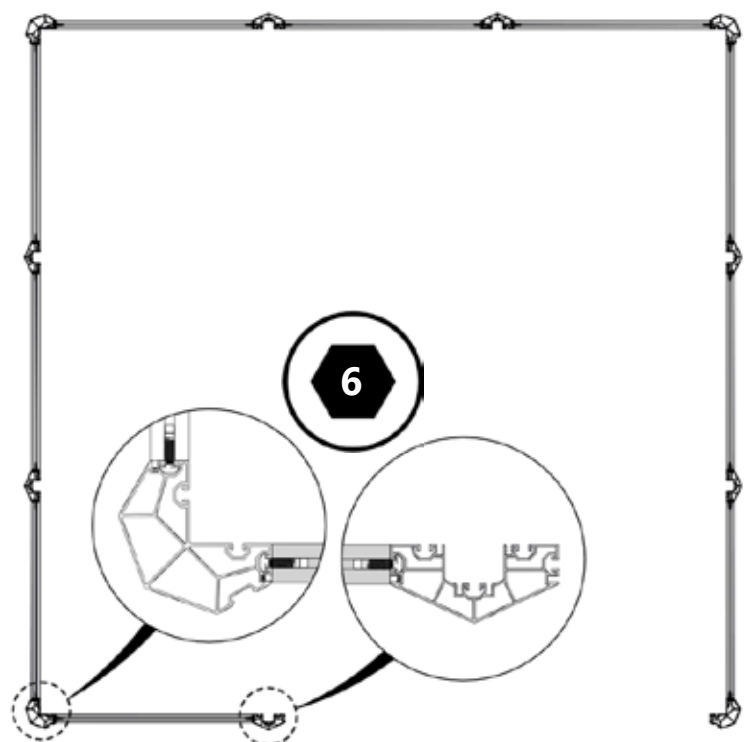

B.18-2 (C)

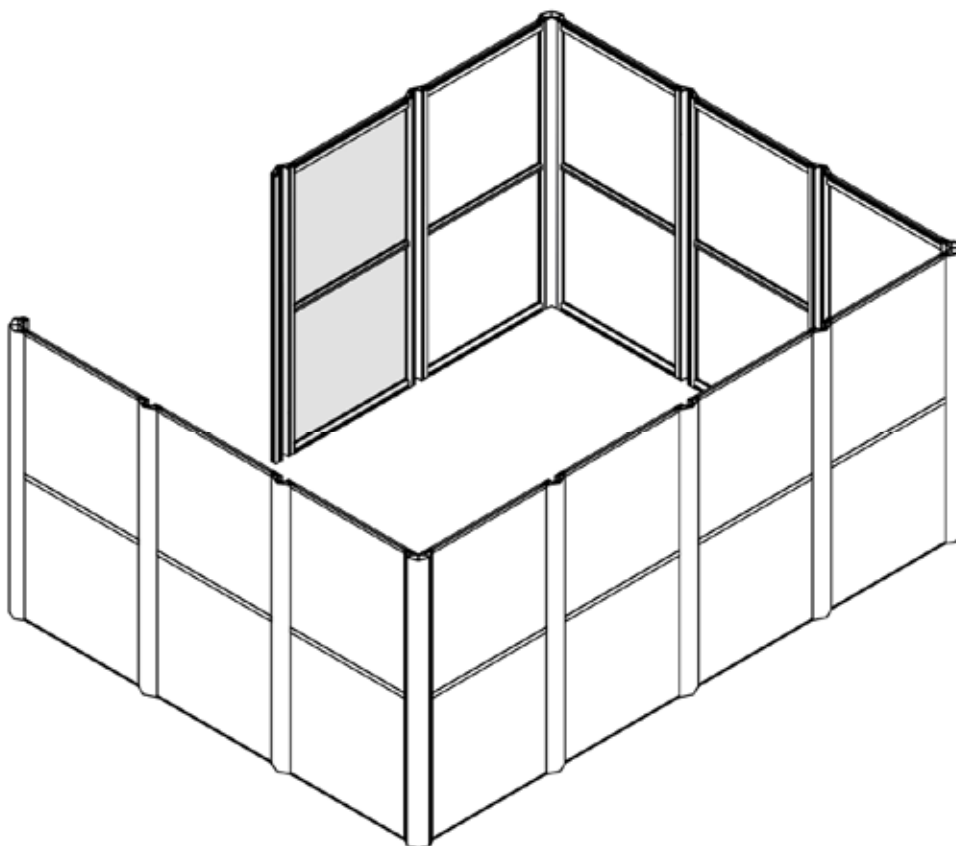
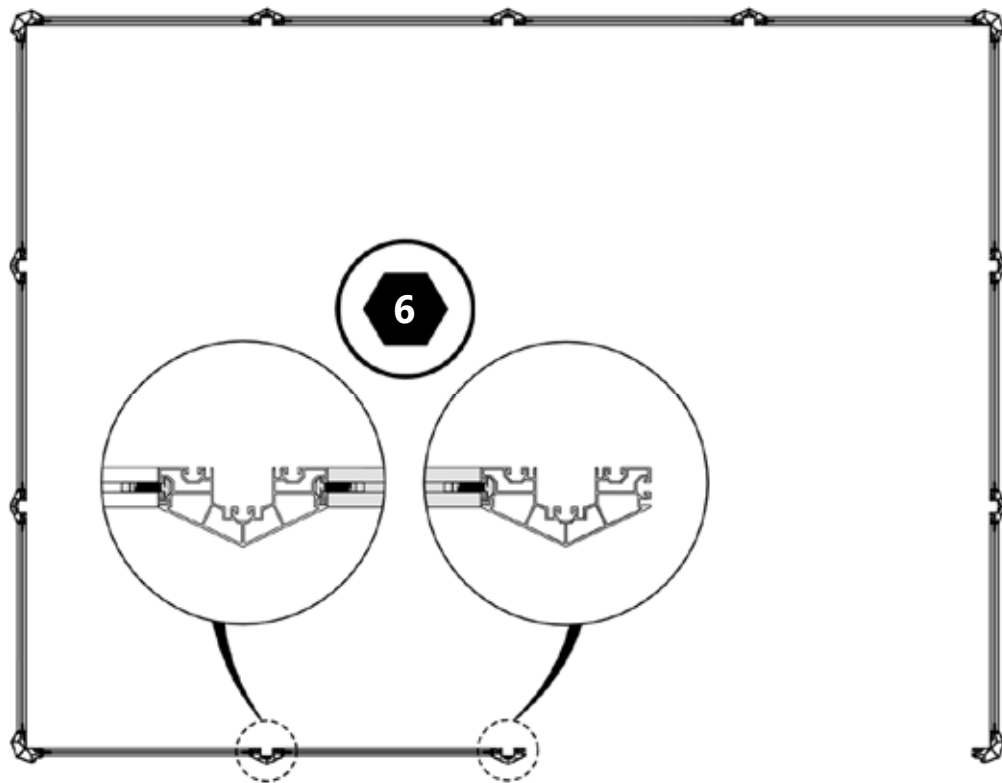

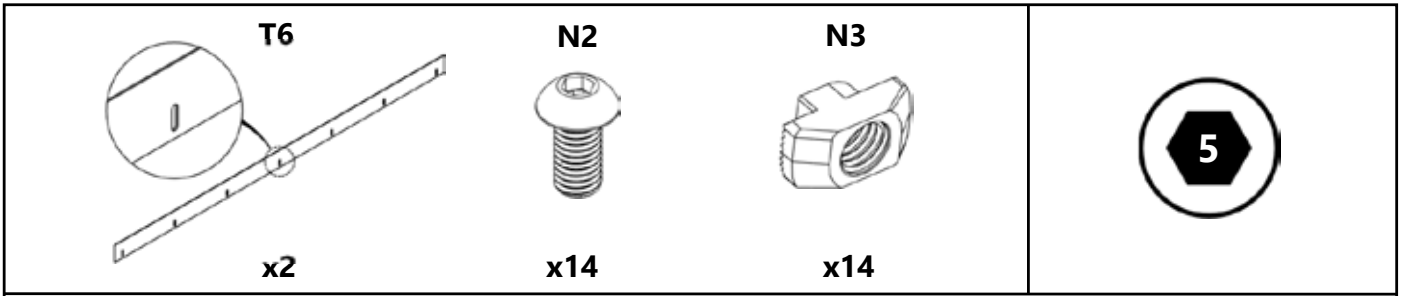

B.19

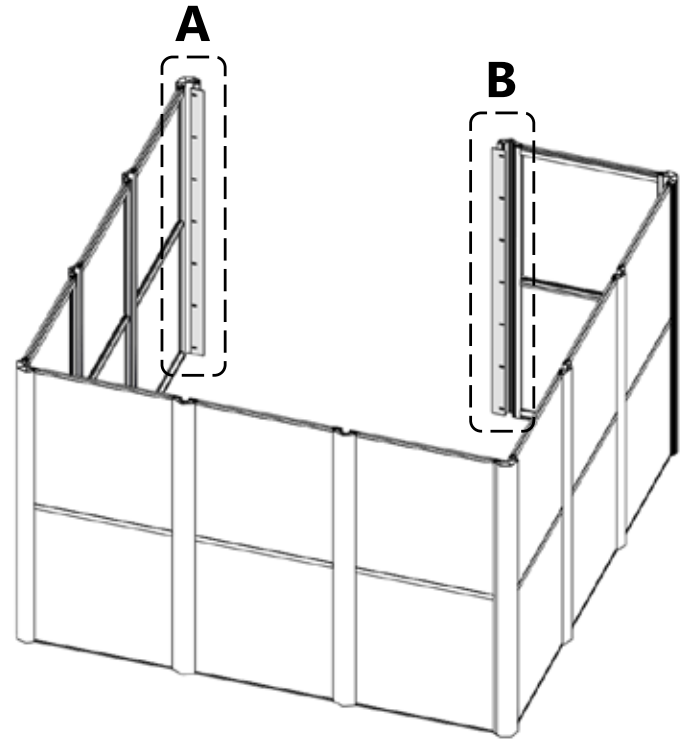
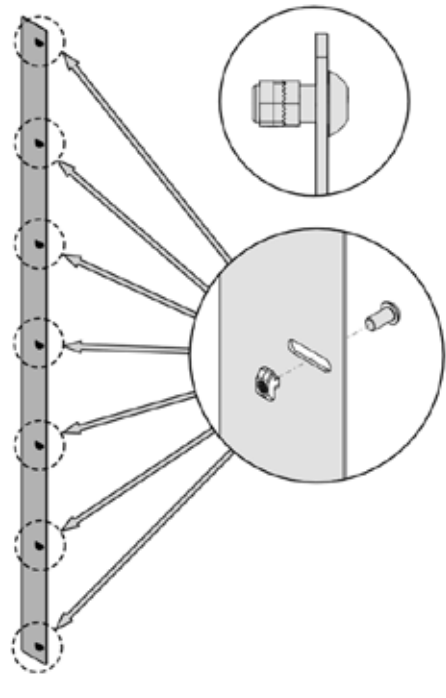

x2

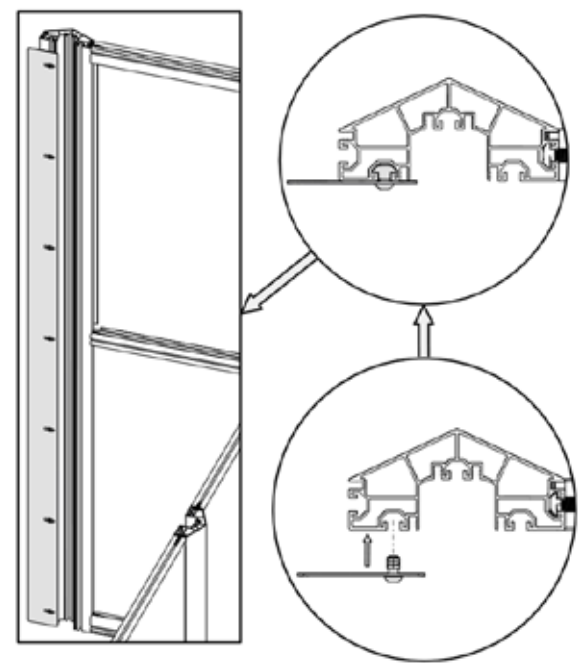
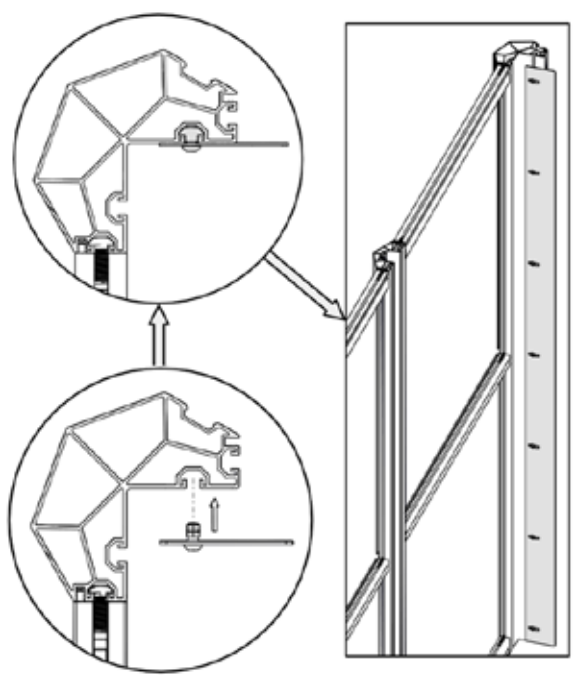

A

B

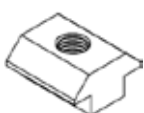

<p>N4</p>  <p>x2</p>	<p>N5</p>  <p>x2</p>	<p>T10</p>  <p>x1</p>	
---	---	---	---

B.20 (A)

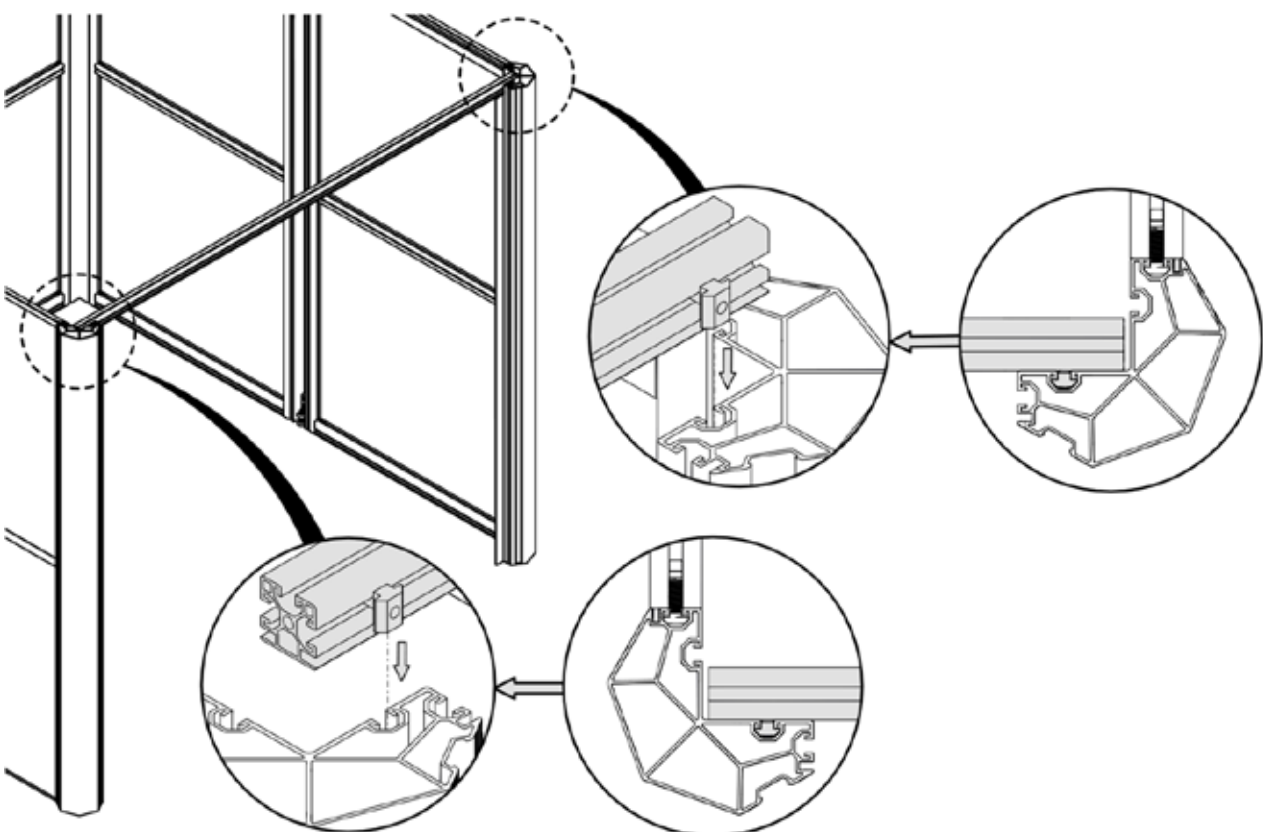
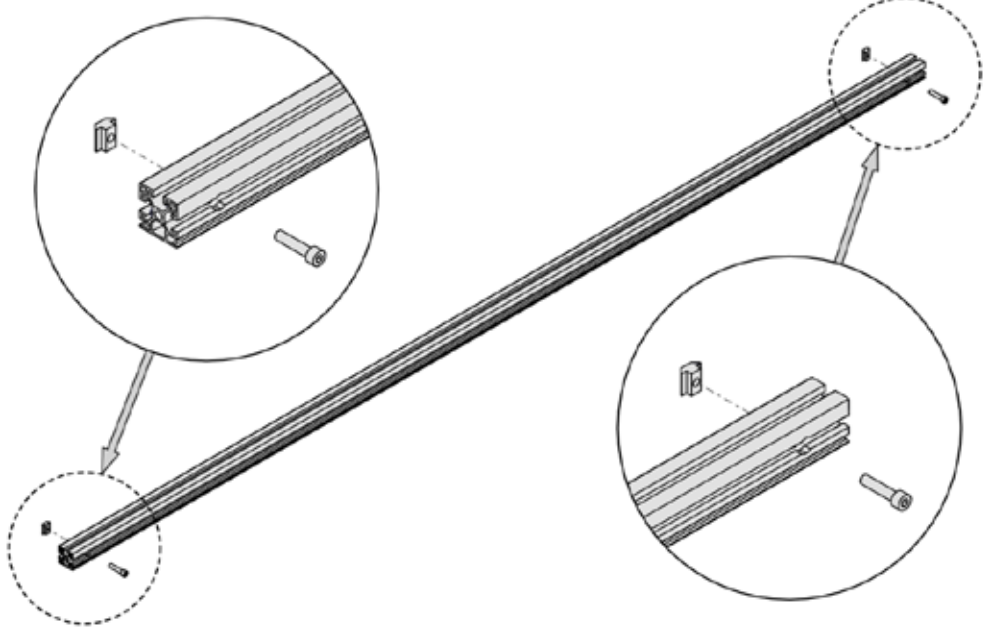

N4



x3

N5

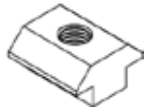

x3

T10

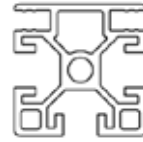

x1



B.20 (B,C)

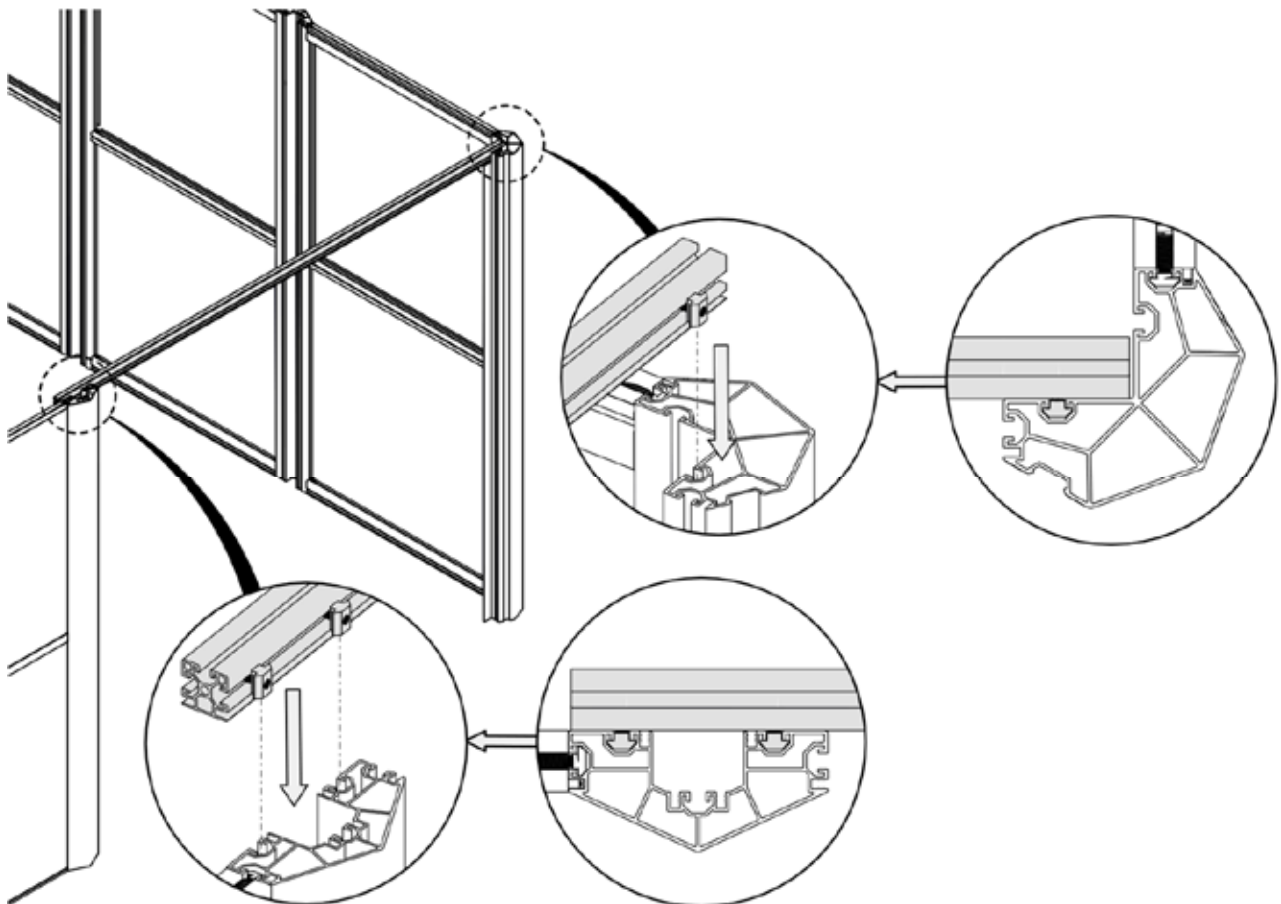
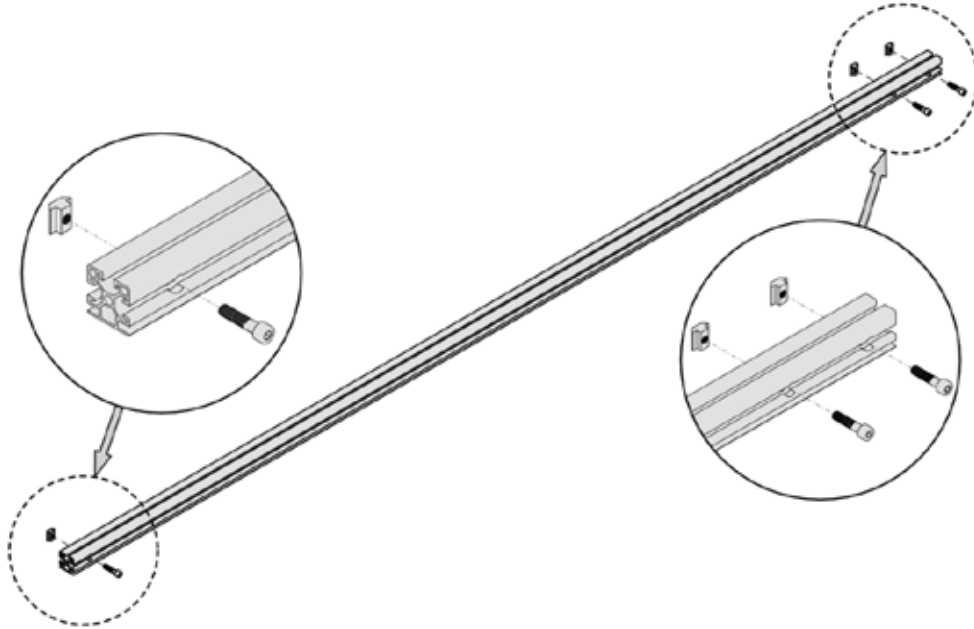

T2



x4

T8

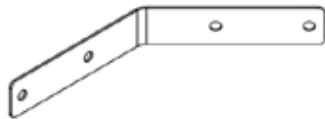

x8

N2



x32

N3



x32







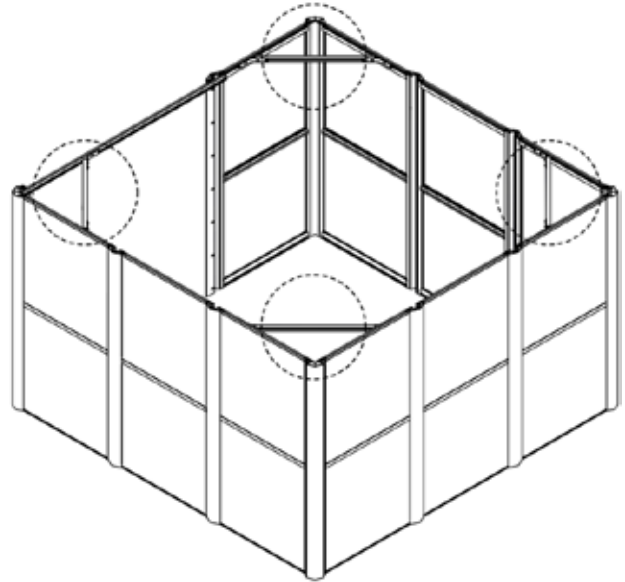
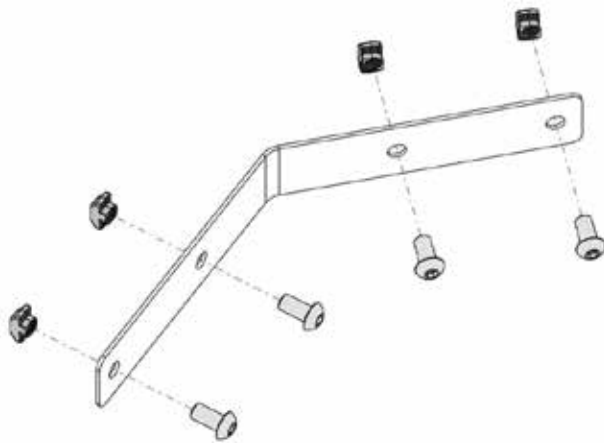

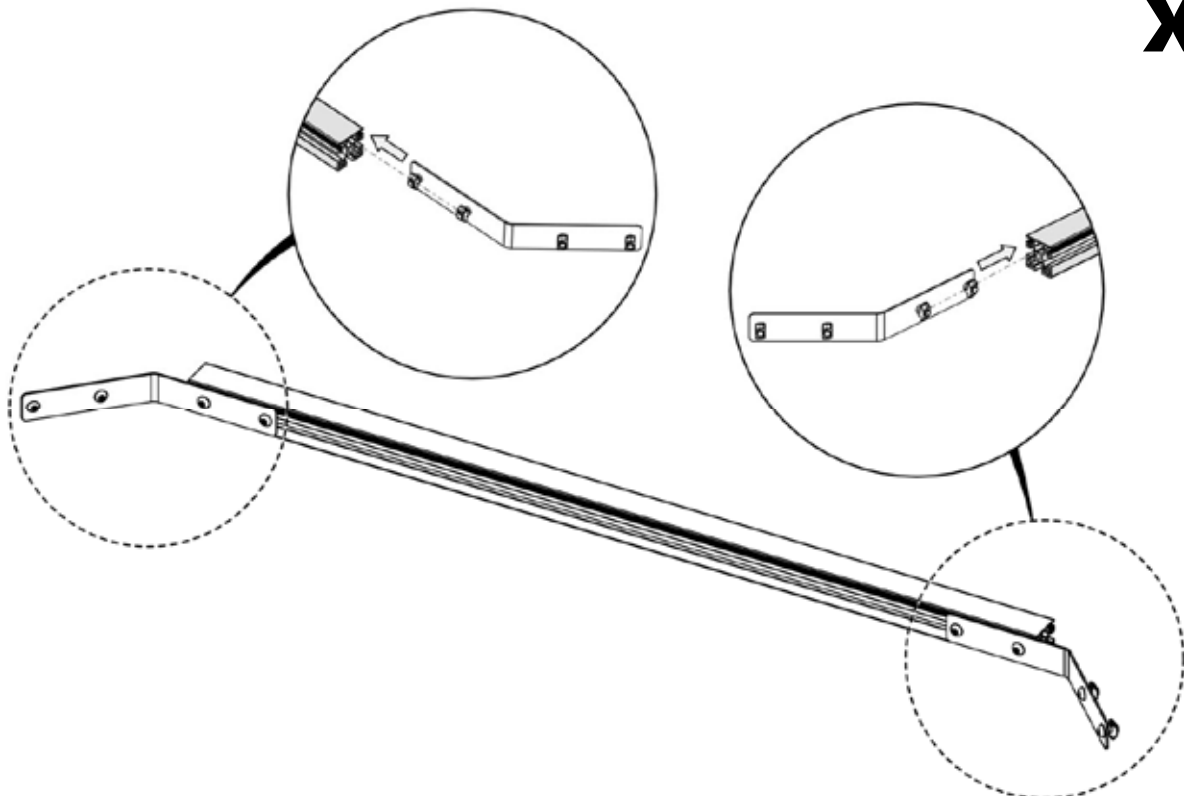

B.21

x8



x4



T7	N2	N3	N8	N9	N10		
							
x2/x3	x4/x6	x4/x6	x4/x6	x4/x6	x2/x3		

B.22

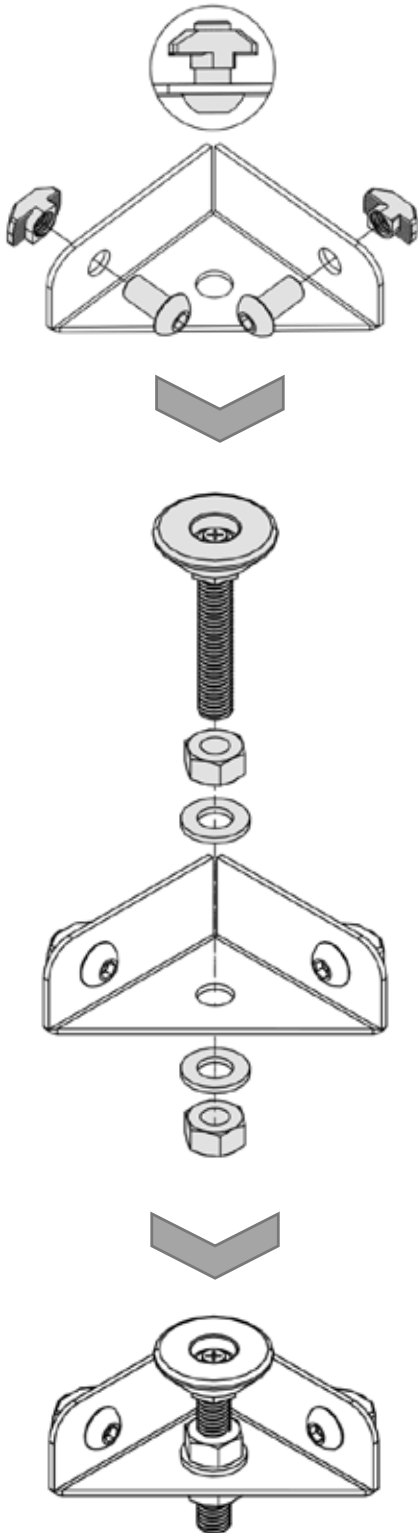





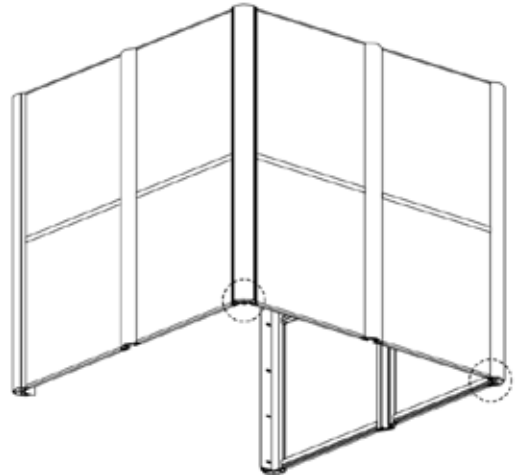

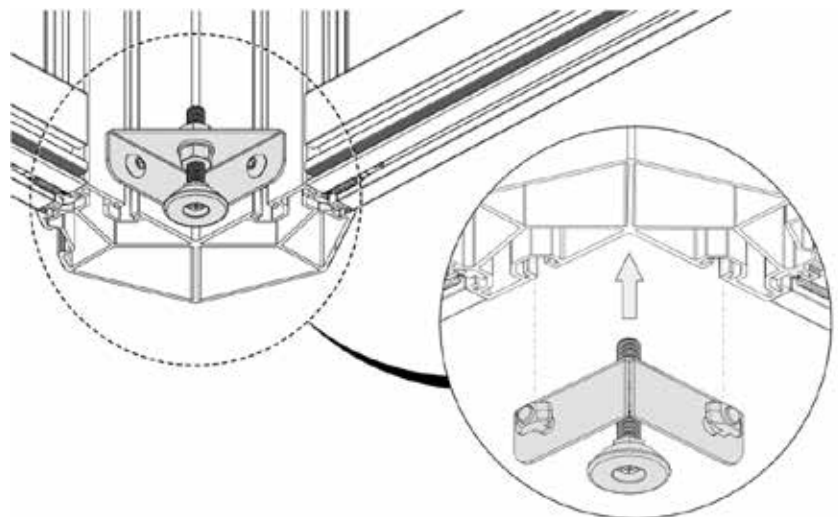
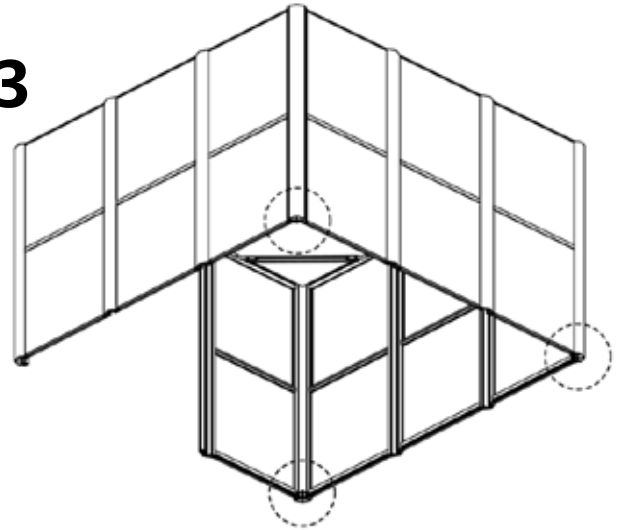

Ansicht von unten / Bottom view

A: x2

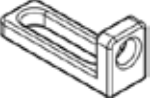

B,C: x3



N3	N6	N7	N8	N9	N10	 
						
x10/x16/x20	x5/x8/x10	x10/x16/x20	x10/x16/x20	x10/x16/x20	x5/x8/x10	

B.23

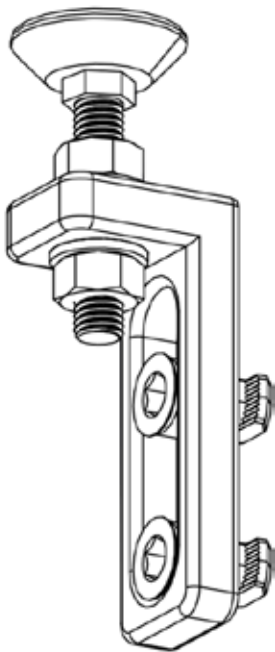
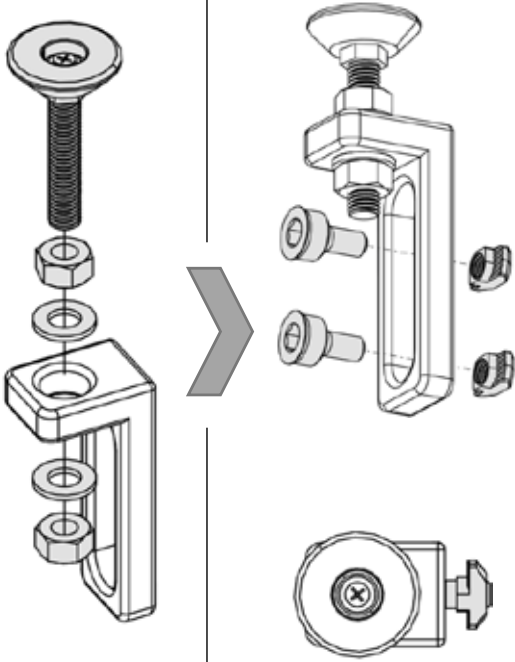

A: P1 x3; P2 x2

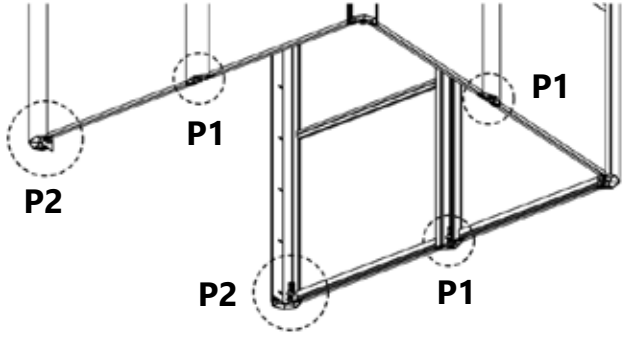

B: P1 x7; P2 x1



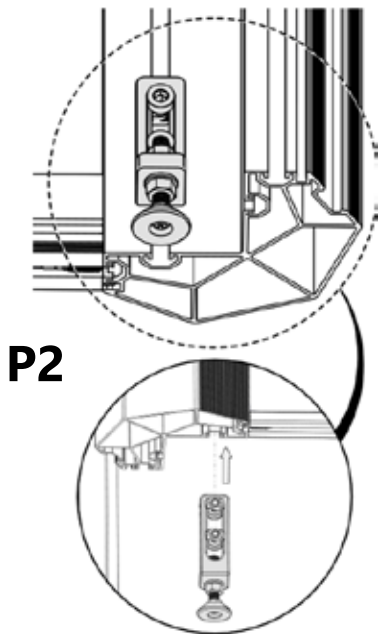
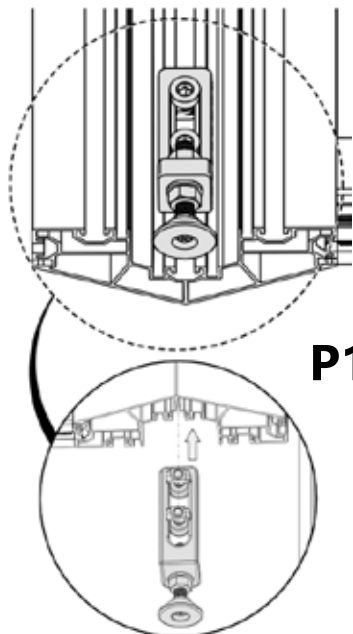
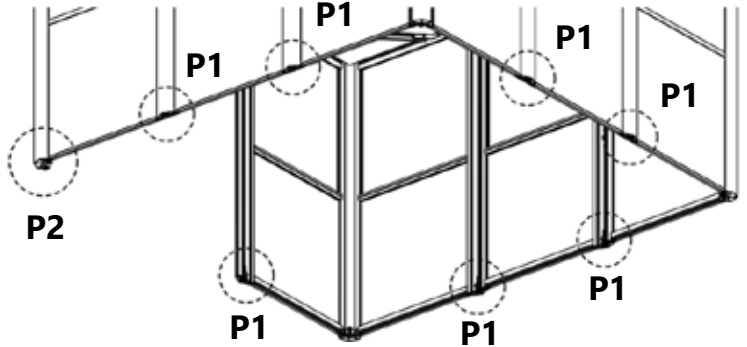



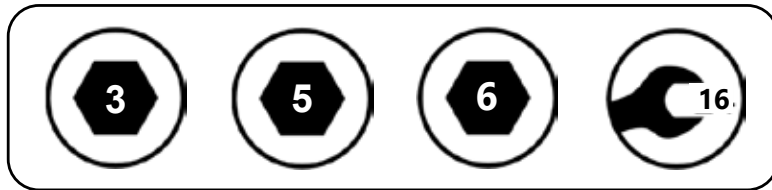







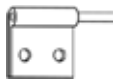
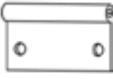

C: P1 x9; P2 x1

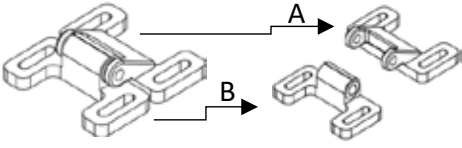
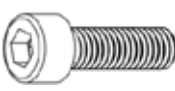

TÜR OHNE FENSTER
DOOR WITHOUT WINDOW



ART. NR.	OVERVIEW	NAME	QTY	ERP (anodized black)
TA1		B-Profil / B-profile 475	4	00005323 (00005324)
TA2		C-Profil / C-profile 475	2	00005328 (00005329)
TA3		C-Profil / C-profile 2250	1	00004153 (005332)
TA4		C-Profil mit Durchgangbohrungen/ C-profile with holes 2250	1	00004117 (00004549)
TA5		D-Profil mit Griffbohrungen/ D-profile with grip holes 2250	1	00005333 (00005334)
TA6		Platte / plate 494x1112x4	4	00005782
TA7		Halteblech für Lenkrolle/ Retaining plate for castor	1	00005339
TA8		Sichtschutzblech mittig/ visibility protection sheet middle 2205	1	00005336
NA1		Gewindeformverbinder/ Thread forming connector	16	00003998
NA2		Zylinderschraube gewindefurchend/ cap screw threaded DIN7500E M8x65	8	00003822
NA3		Unterlegescheibe / washer ISO 7089 - 8	6	00002796
NA4		Nutenstein / T-Slot stone M8	2	00003789
NA5		Zylinderschraube / Socket head screw ISO 4726 M8x20	2	00002794

ART. NR.	OVERVIEW	NAME	QTY	ERP (anodized black)
NA6		Bügelgriff / handle	1	00002785
NA7		Schraube / screw ISO 7380 M8x16	33	00003962
NA8		Hammermutter Nut / hammer nut 10 M8	33	00005357
NA9		Griff / handle	1	00003815
NA10		Unterlegescheibe / washer ISO 7089 - 4	2	00003880
NA11		Zylinderschraube / Socket head screw ISO 4726 M4x35	2	00003879
NA12		Scharnierprofil links / Hinge profile left	4	00003802
NA13		Scharnierprofil rechts / Hinge profile right	4	00003801
NA14		Scharnierprofil mitte / Hinge profile center	4	00004365
NA15		Unterlegescheibe / washer ISO 7089 - 6 Polyamid	8	00002954
NA16		Scheibe / Washer ISO 7089 - 10	2	00002953
NA17		Mutter / Hex nut ISO 4032 - M10	2	00003346
NA18		Lenkrolle / Castor	1	00005346
NA19		A. Türschnapper Gegenstück	1	00005422
		B. Türschnapper Kugelstück	1	
NA20		Zylinderschraube / Socket head screw ISO 4726 M6x20	4	00003792
NA21		Scheibe / Washer ISO 7089 - 6	4	91600366
NA22		Hammermutter Nut / hammer nut 10 M6	4	00005415
NA23		Dichtungsprofil / Sealing profile		00004117
NA24		Keilprofil / Wedge profile		00006041

TA1



x4

NA1



x8



B.24
TBA.1

x2

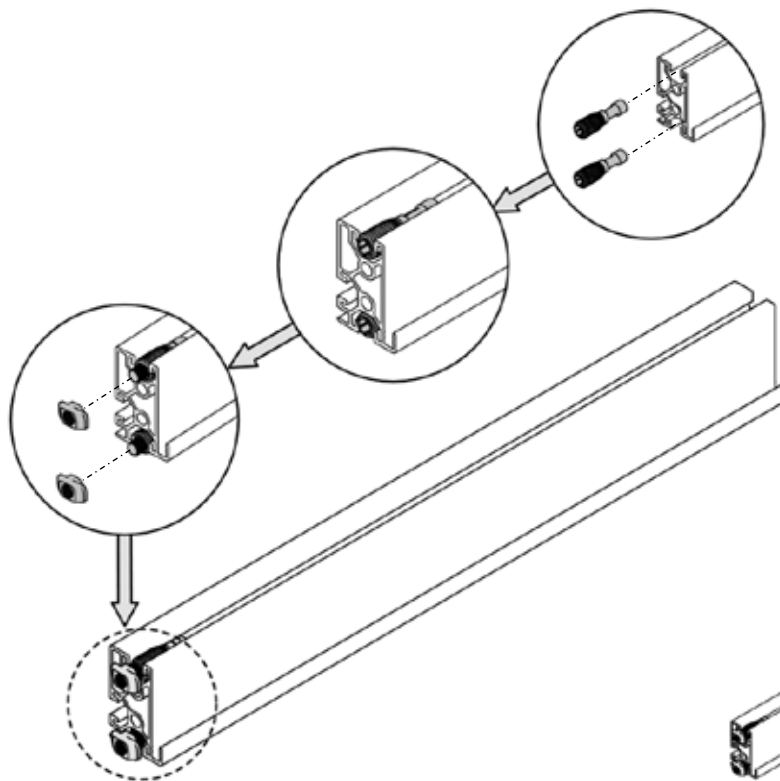

B.25
TBA.2

x2

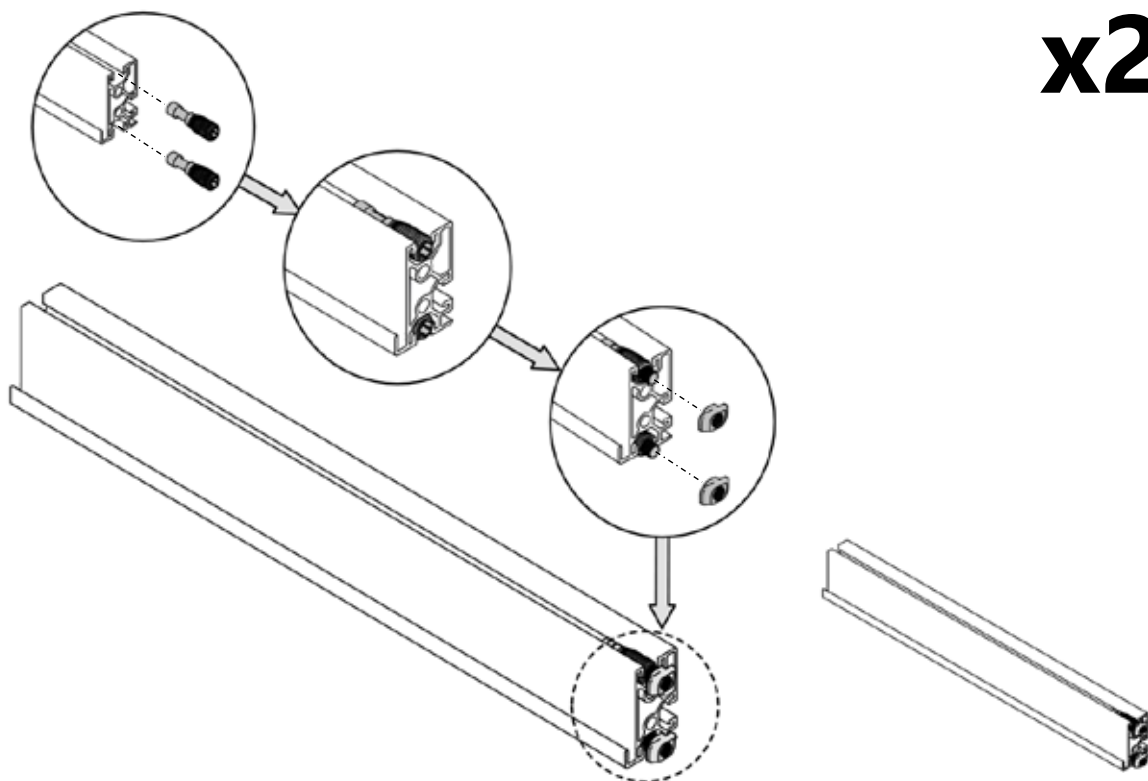

TA2



x2

NA1



x8



B.26
TBA.3

x2

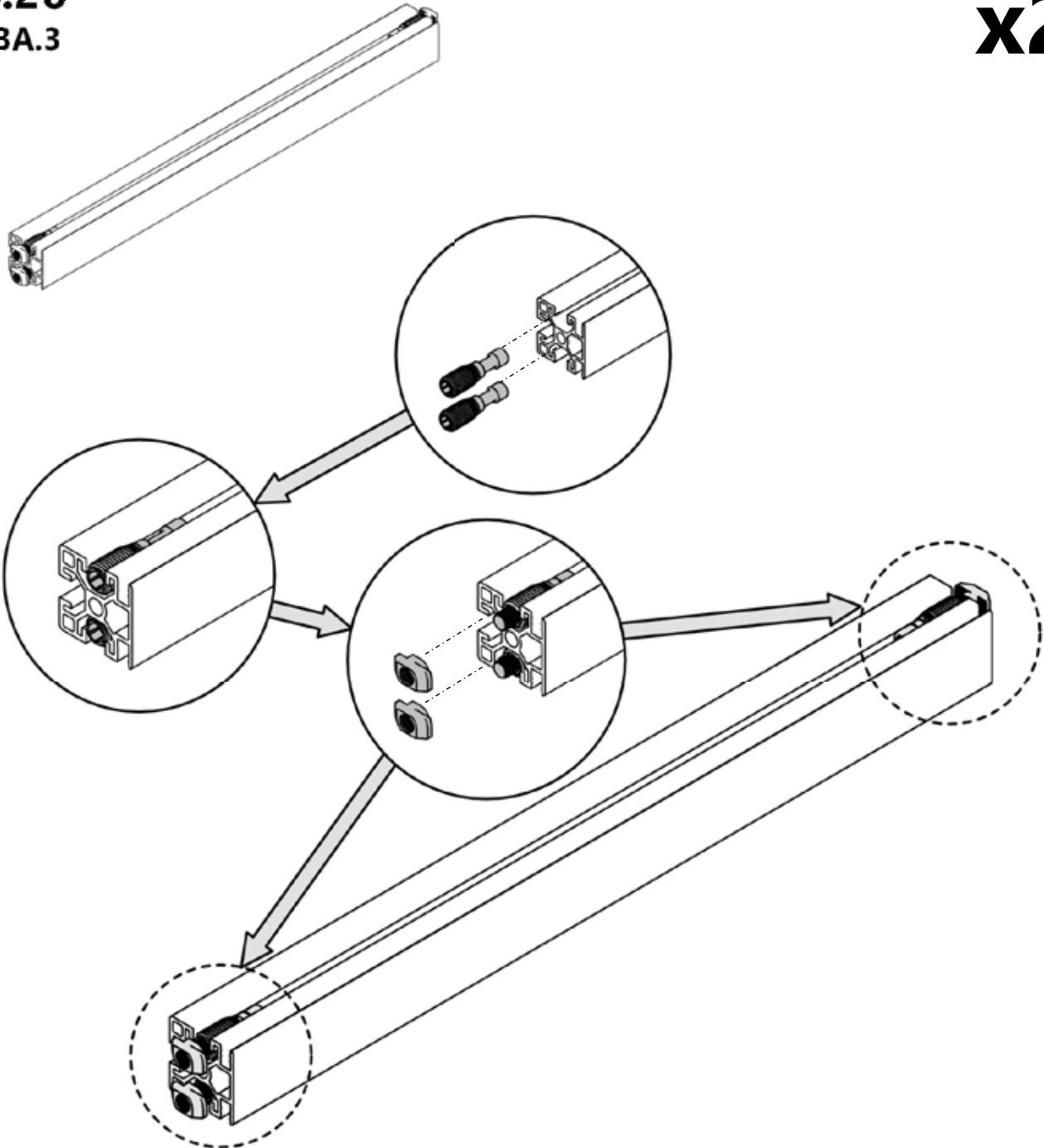

B.27
TBA.4

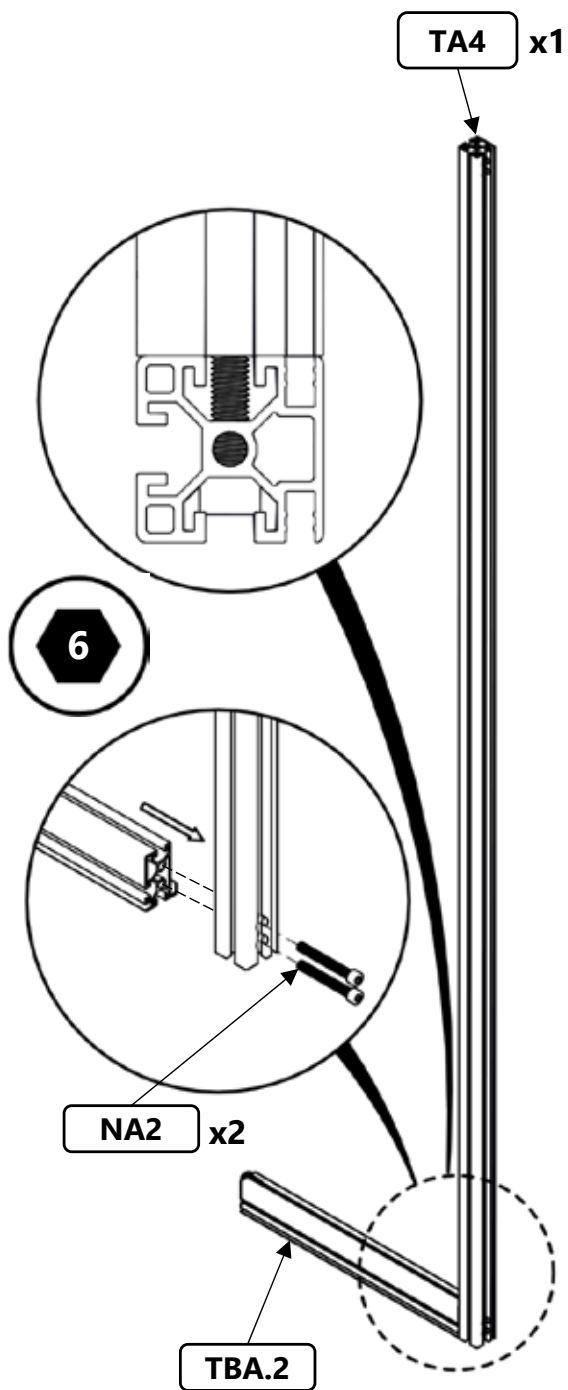

B.28
TBA.5

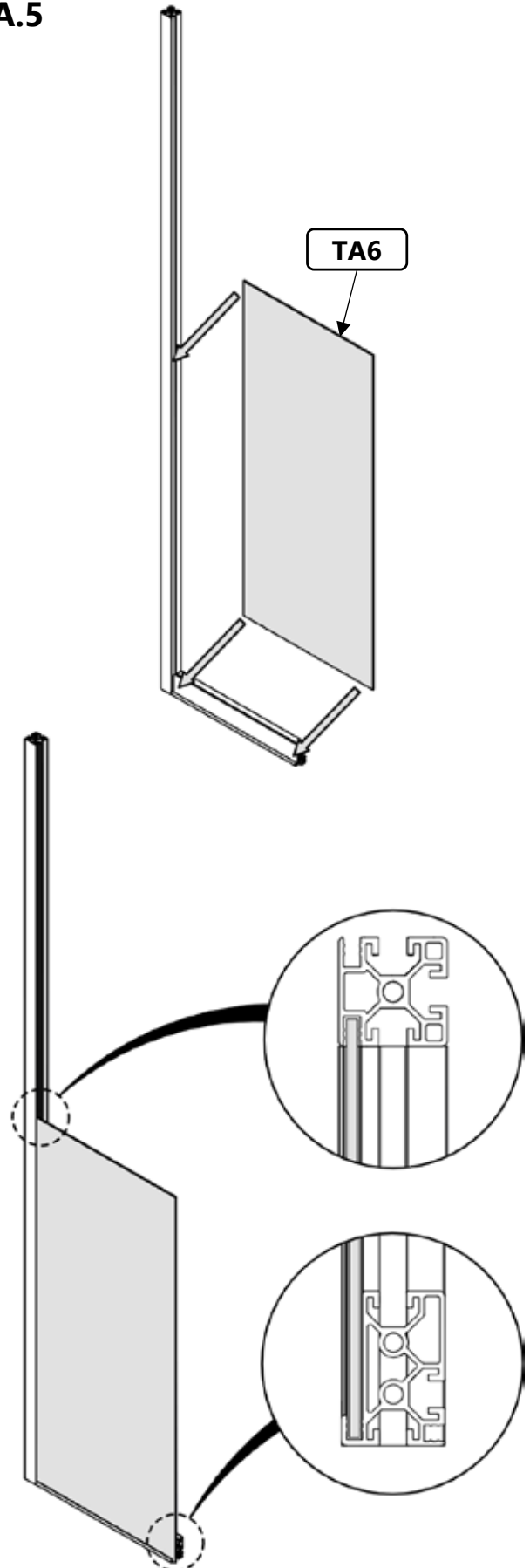

B.29
TBA.6

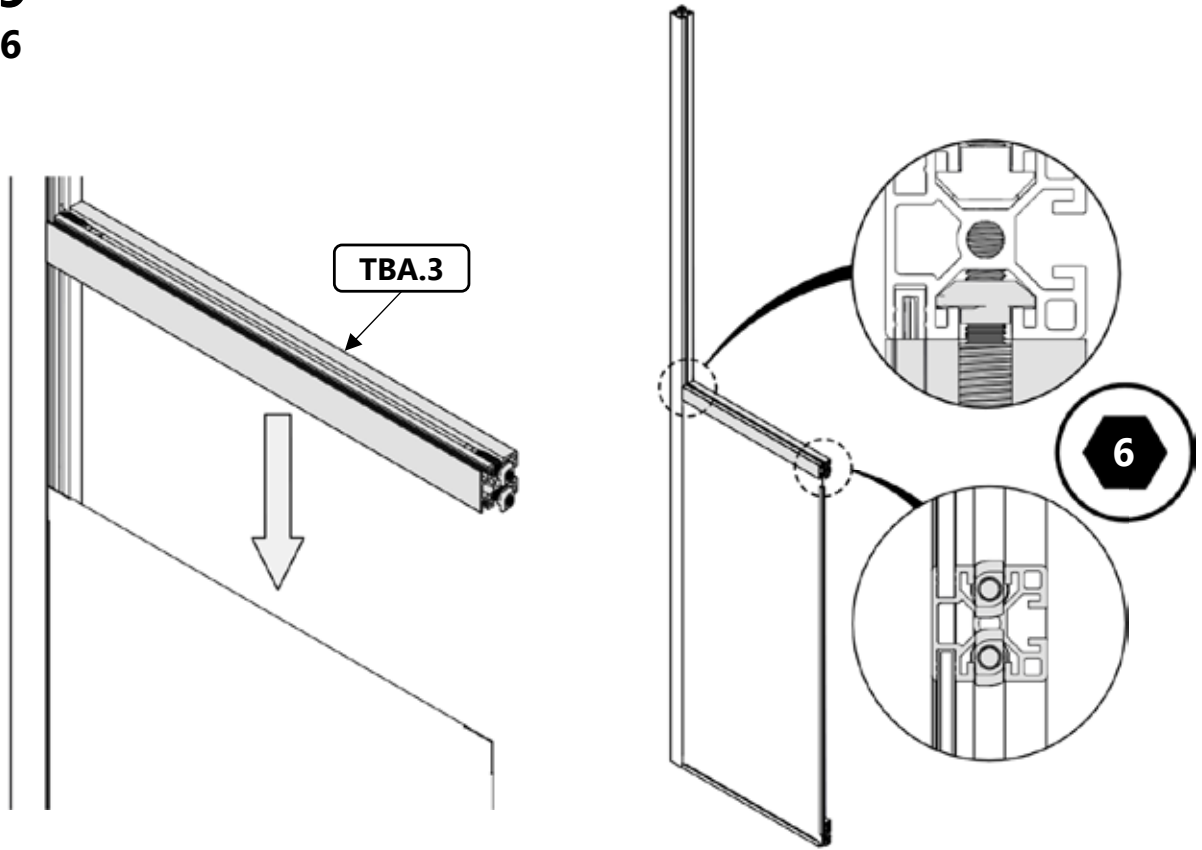

B.30
TBA.7

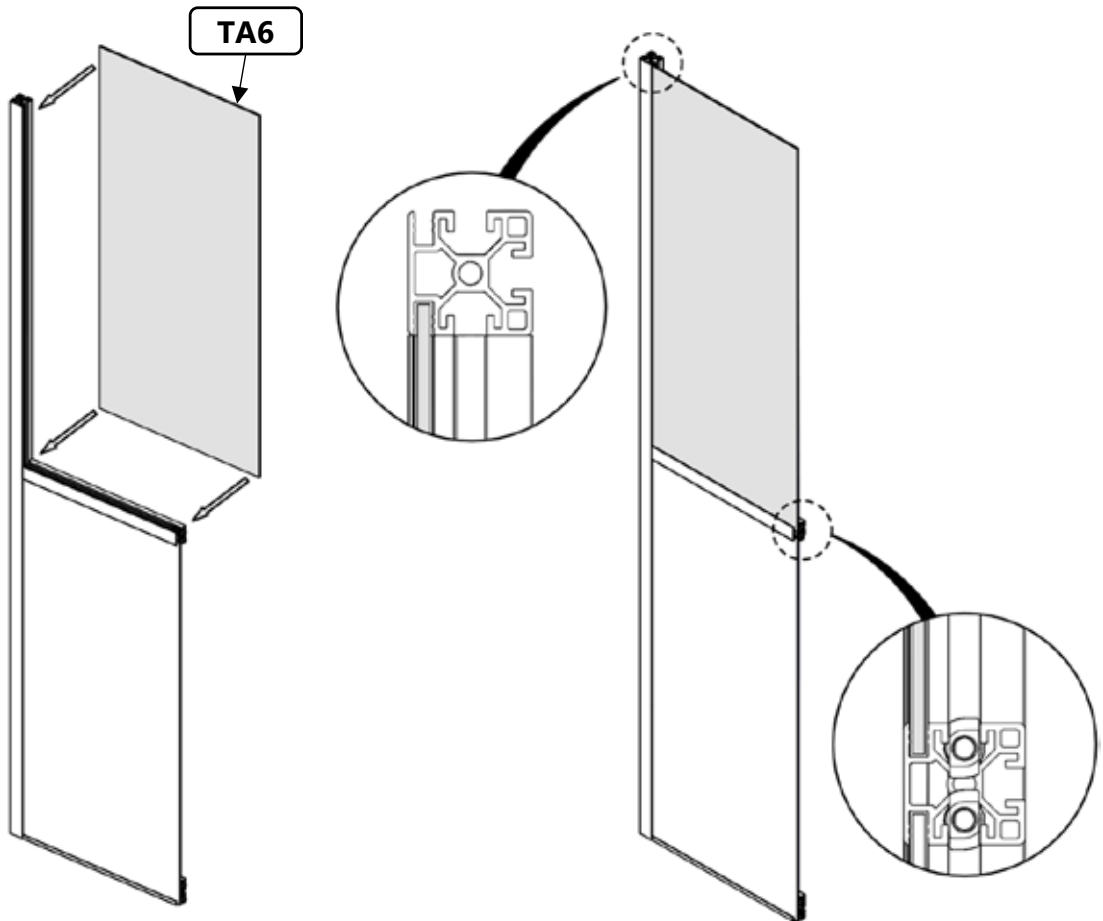

B.31
TBA.8

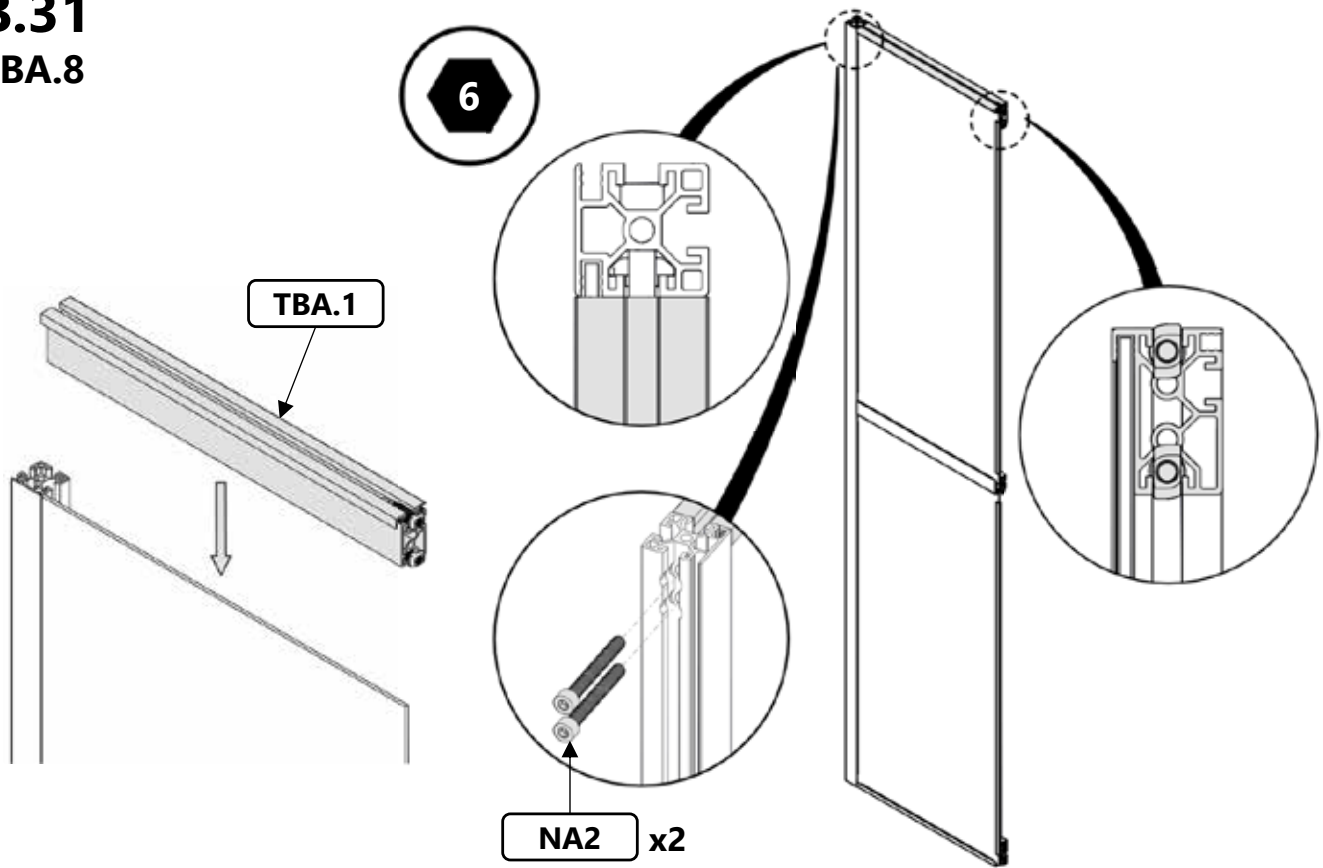

B.32
TBA.9

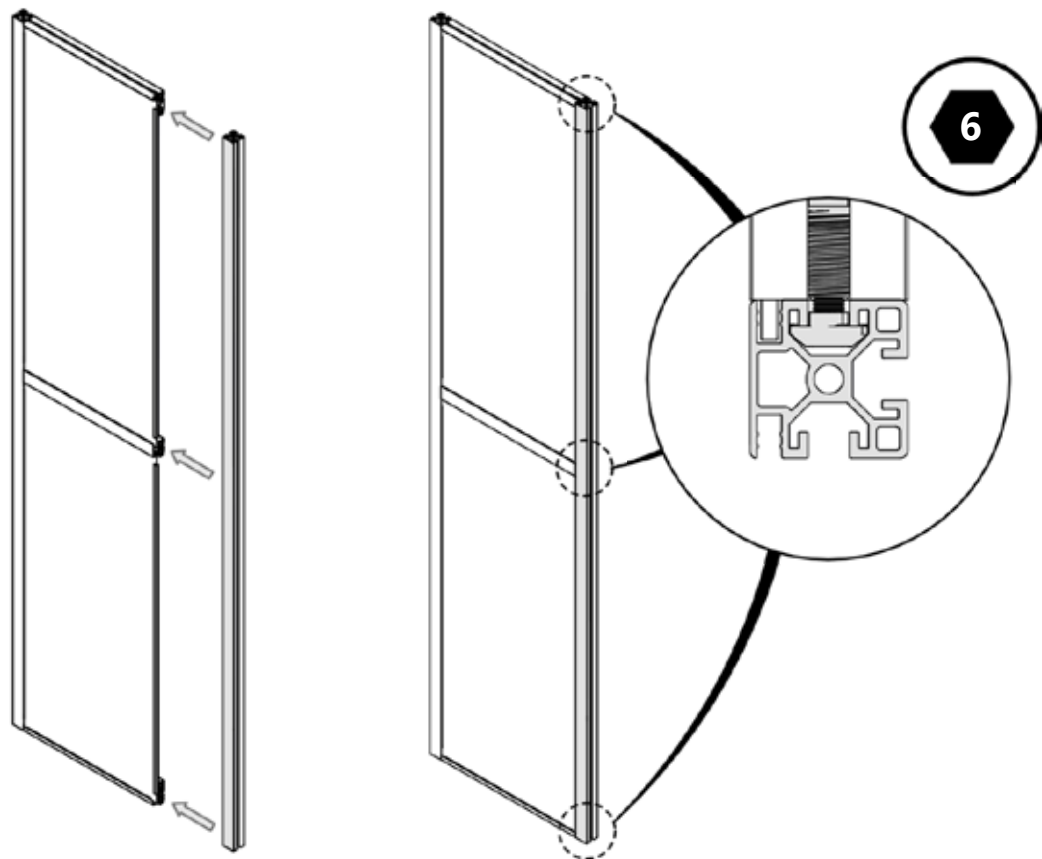

B.33
TBA.10

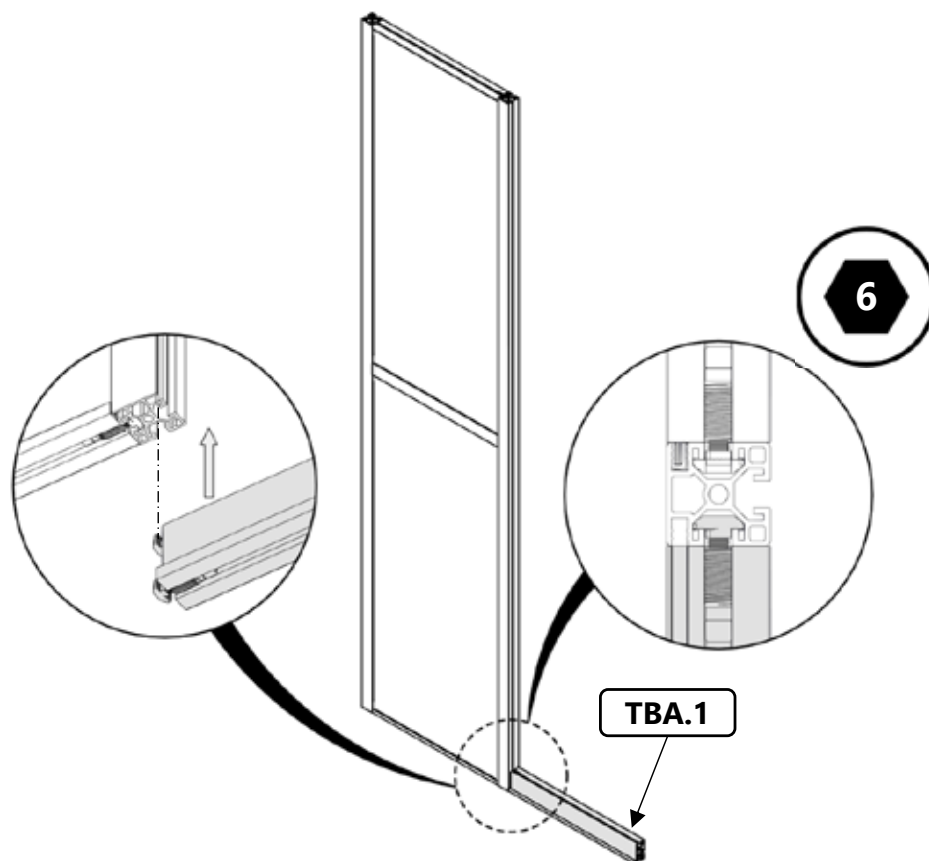

B.34
TBA.11

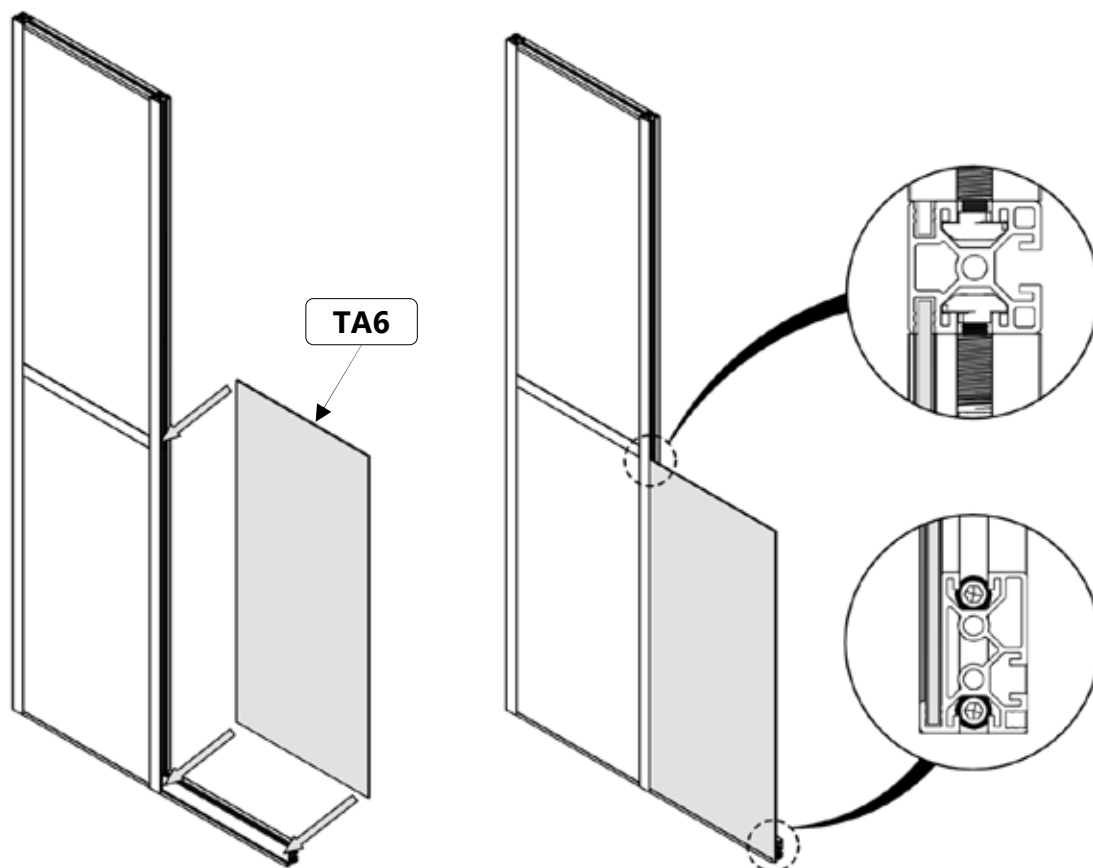

B.35
TBA.12

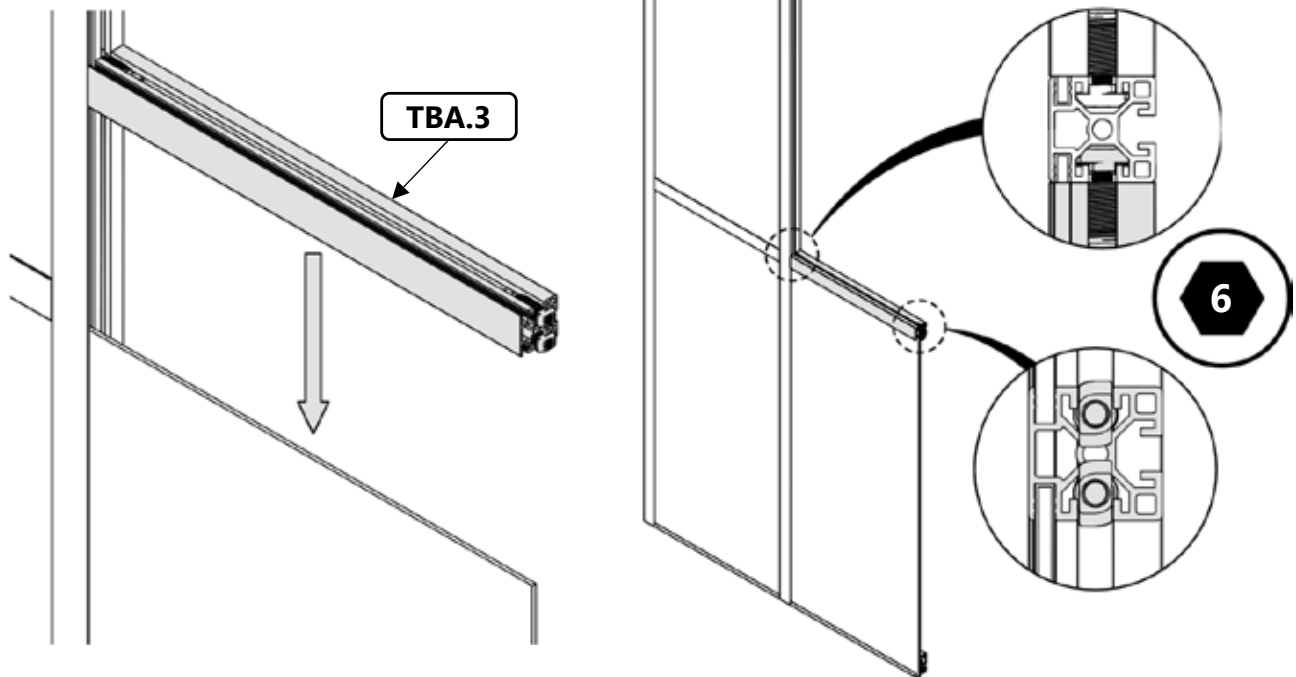

B.36
TBA.13

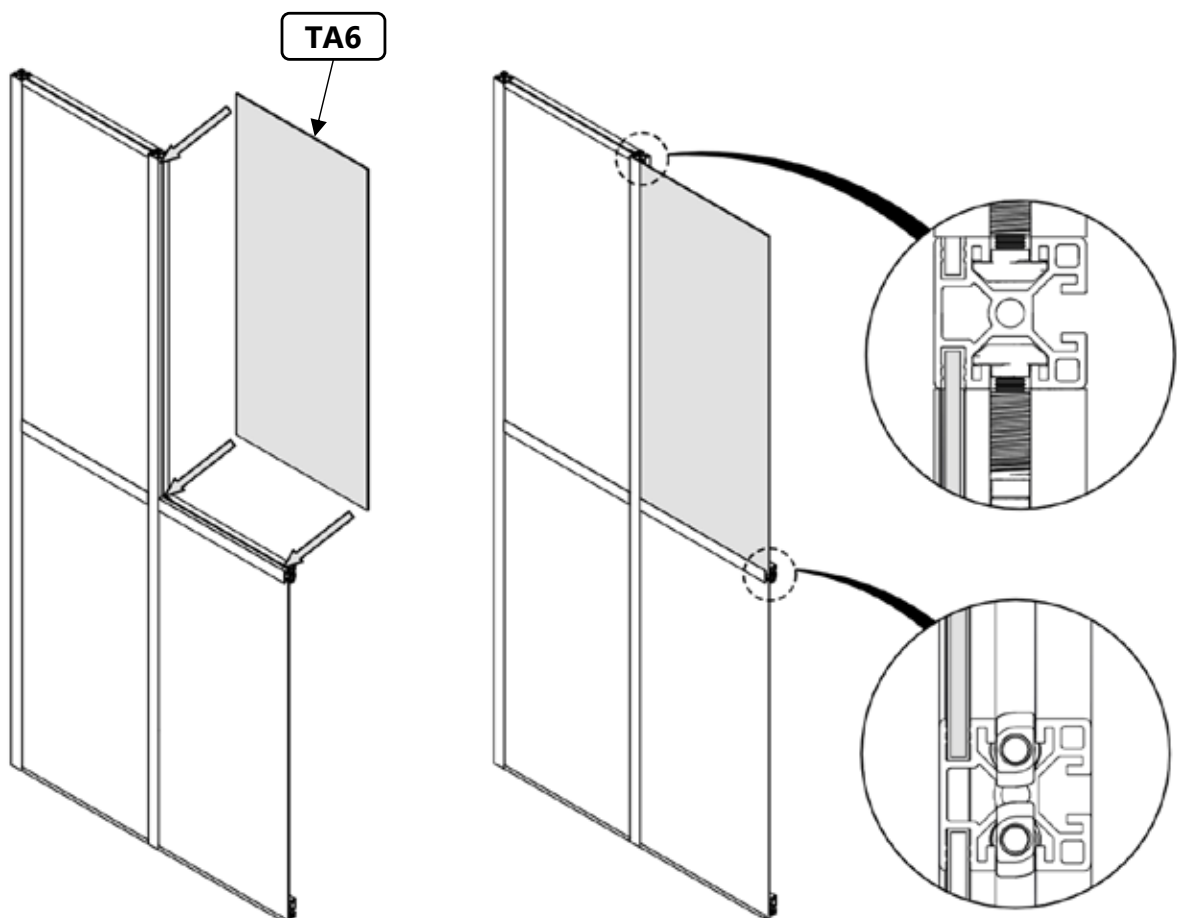

B.37

TBA.14

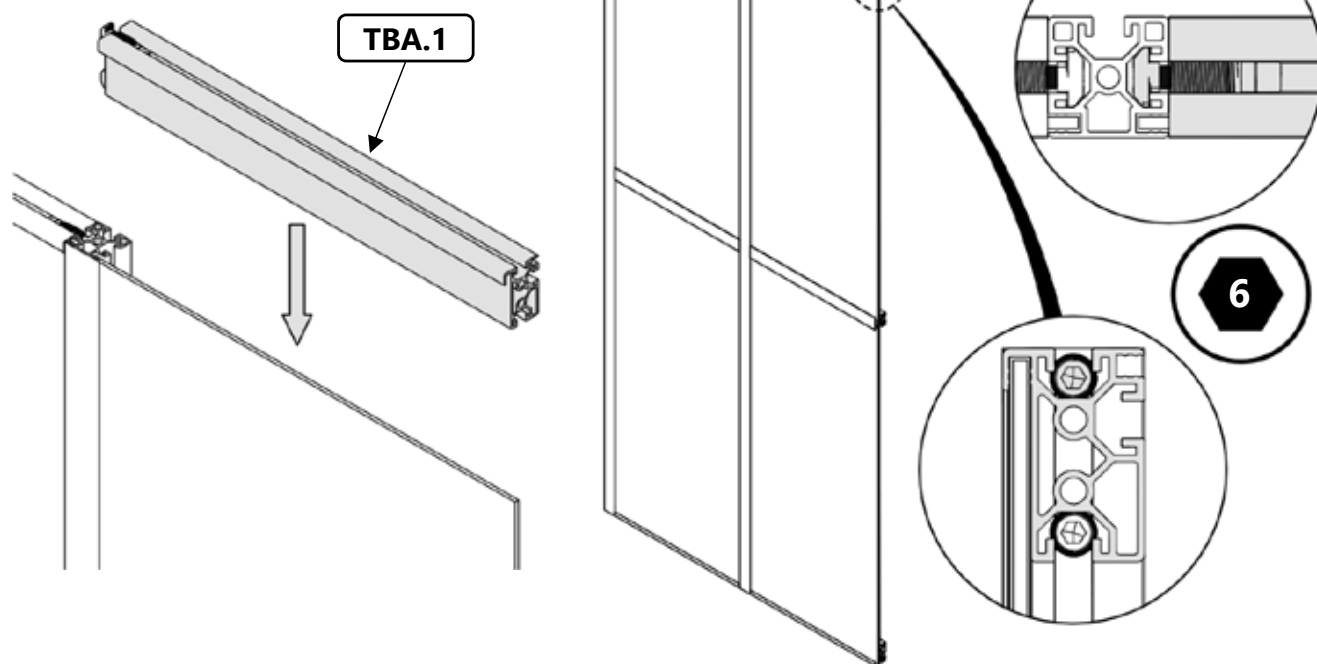

B.38

TBA.15

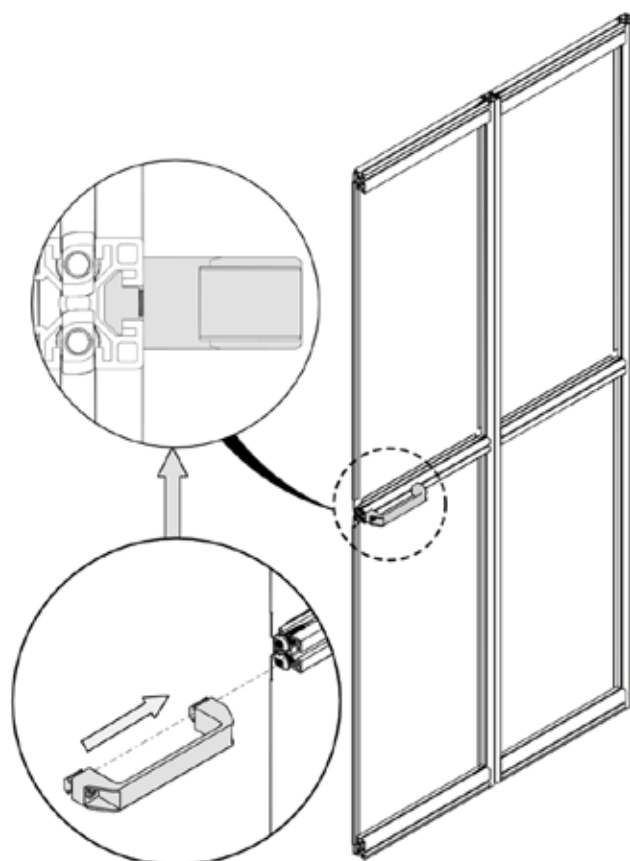
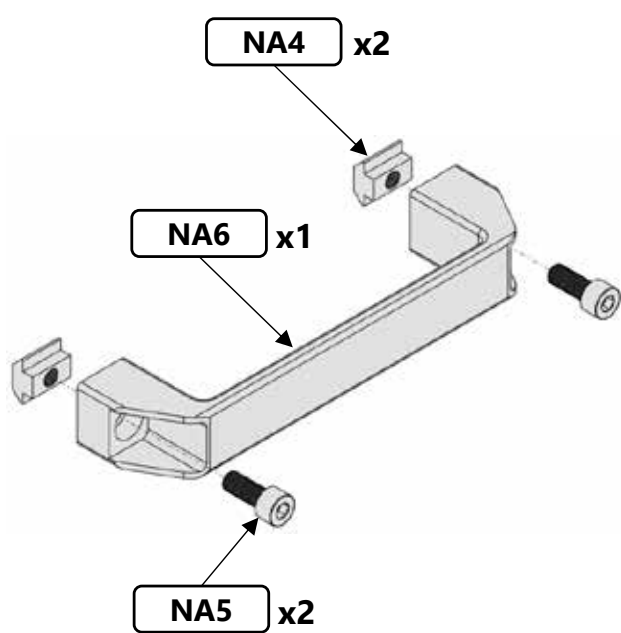

TA7	NA3	NA7	NA8	NA16	NA17	NA18	
x1	x2	x2	x2	x2	x2	x1	

B.39

TBA.16

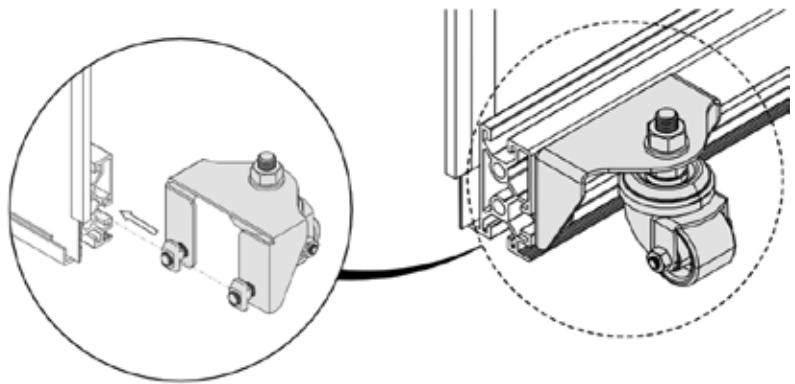
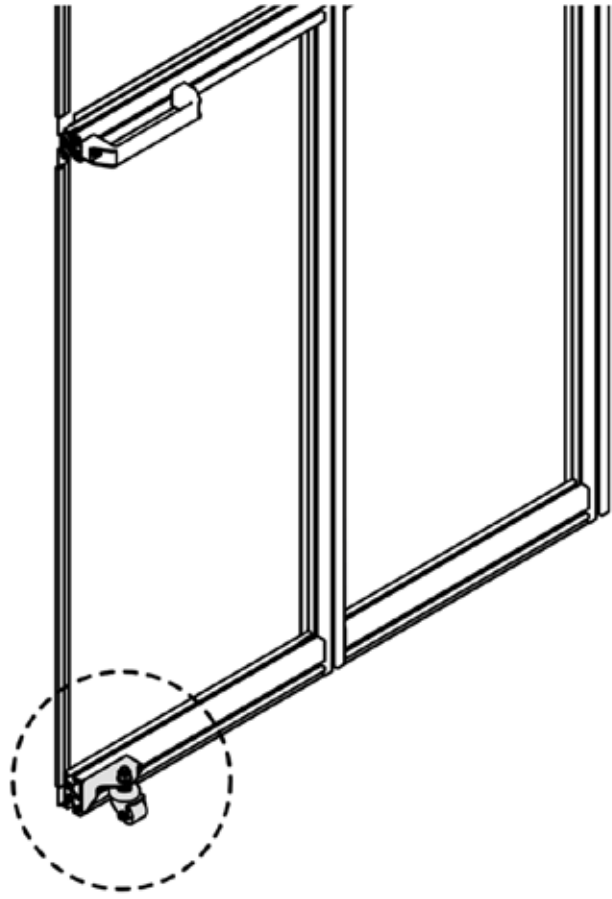
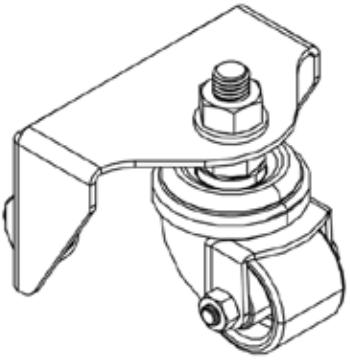
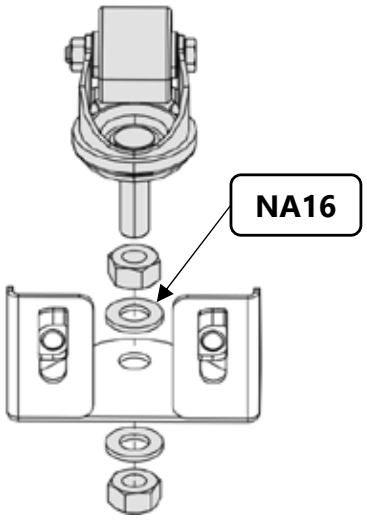
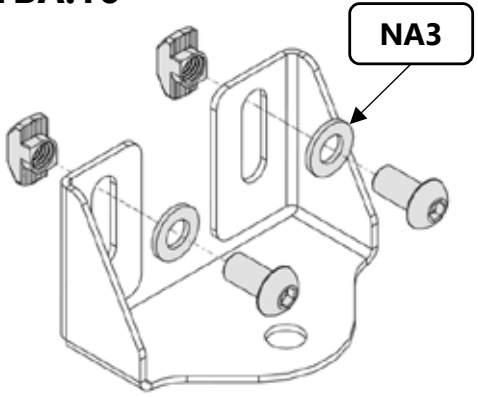

NA19.B

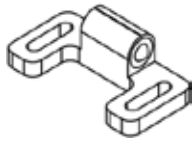

x1

NA20



x2

NA21



x2

NA22







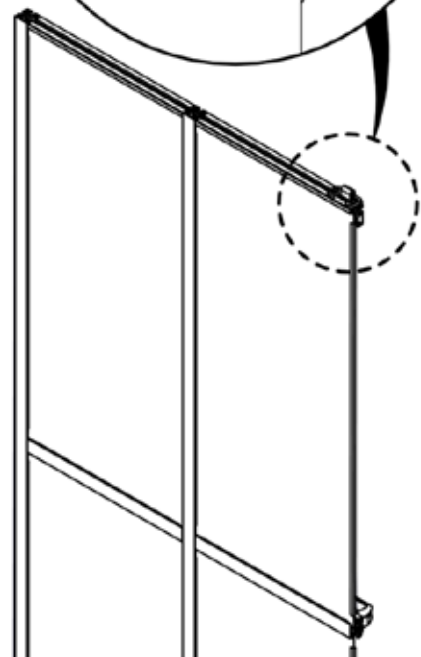
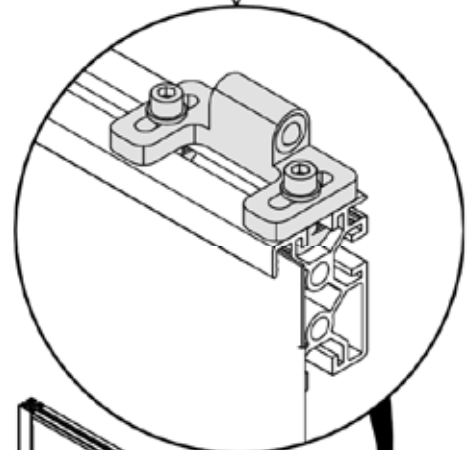
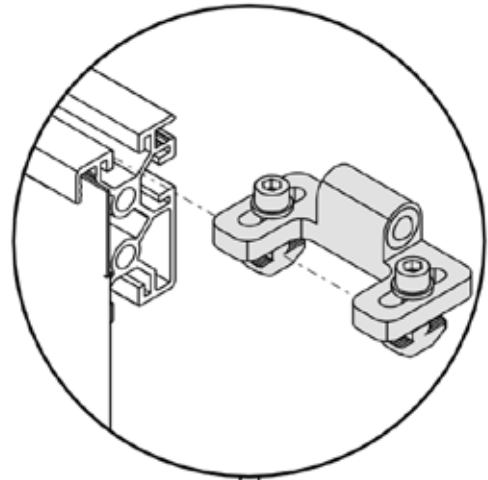
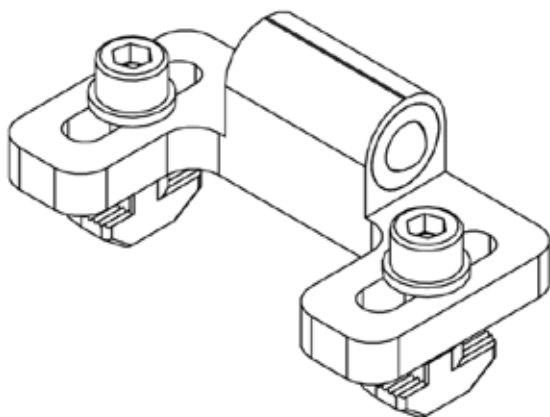
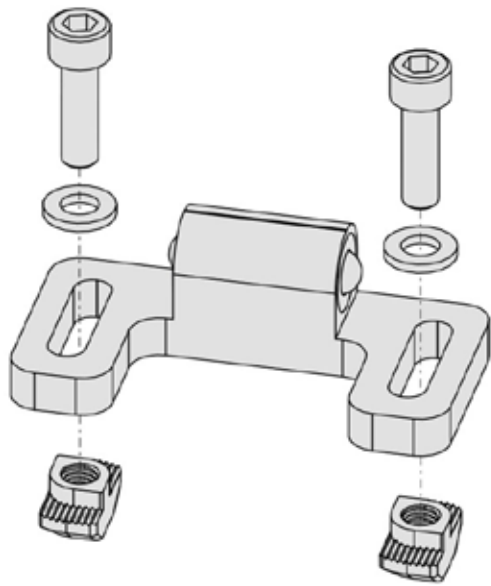

x2



B.40 TBA.17



NA2  x4	NA3  x4	NA9  x1	NA10  x2	NA11  x2	 
---	---	---	--	---	---

B.41
TBA.18

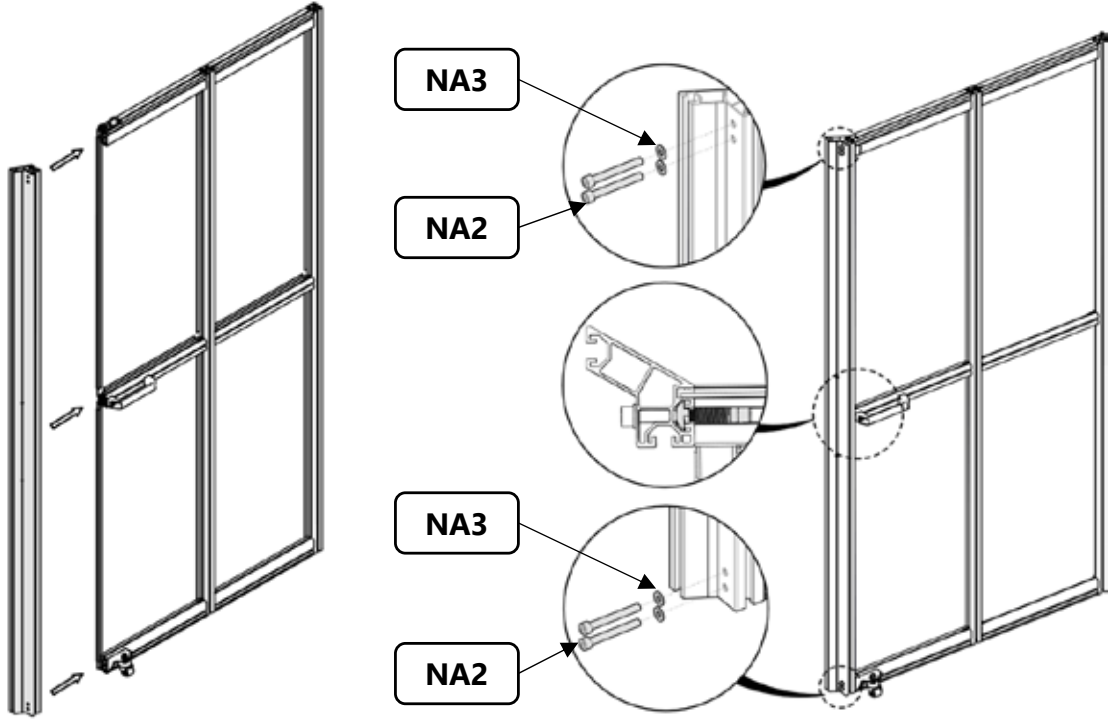

B.42
TBA.19

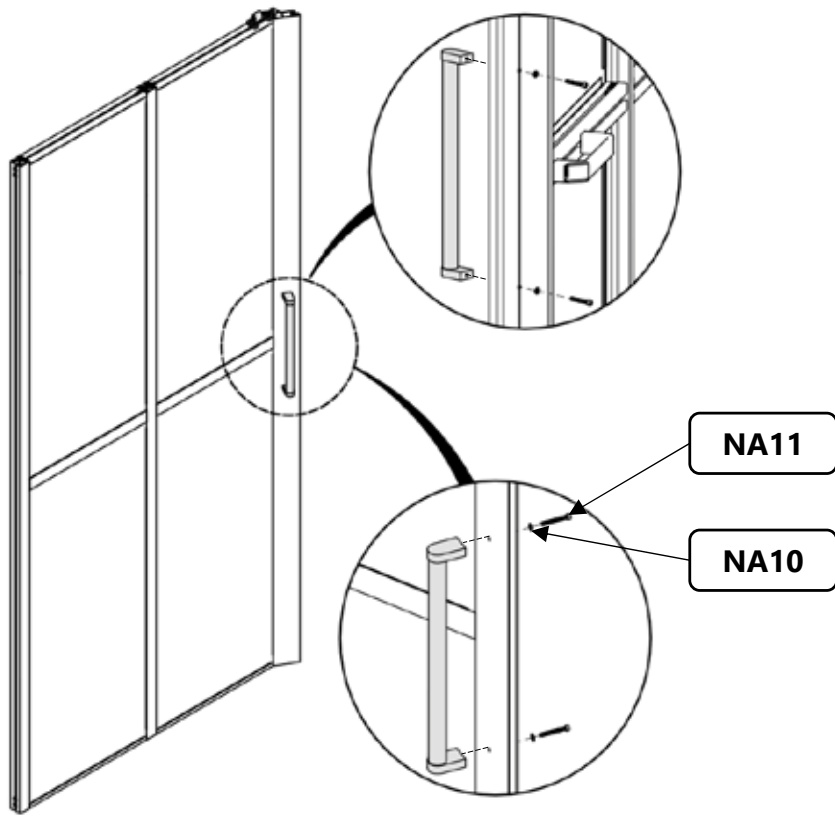

NA24



B.43
TBA.20

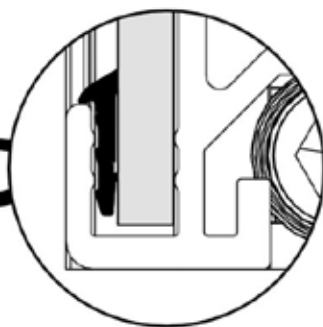
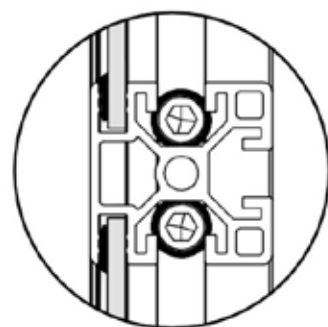
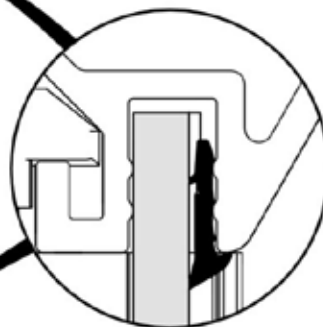
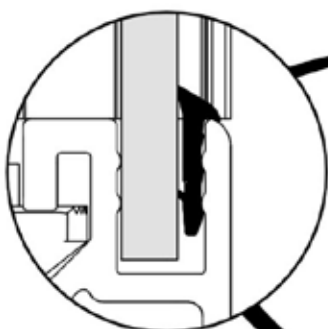
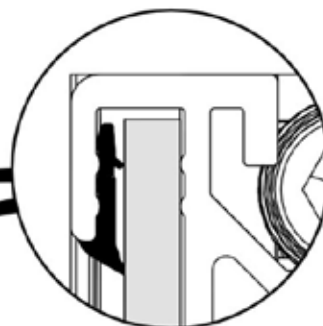
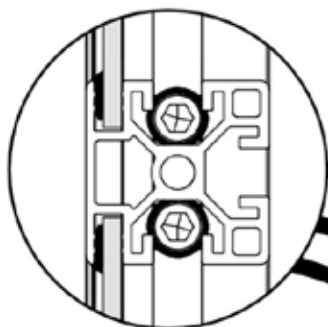
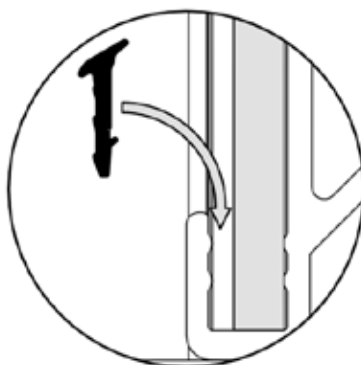

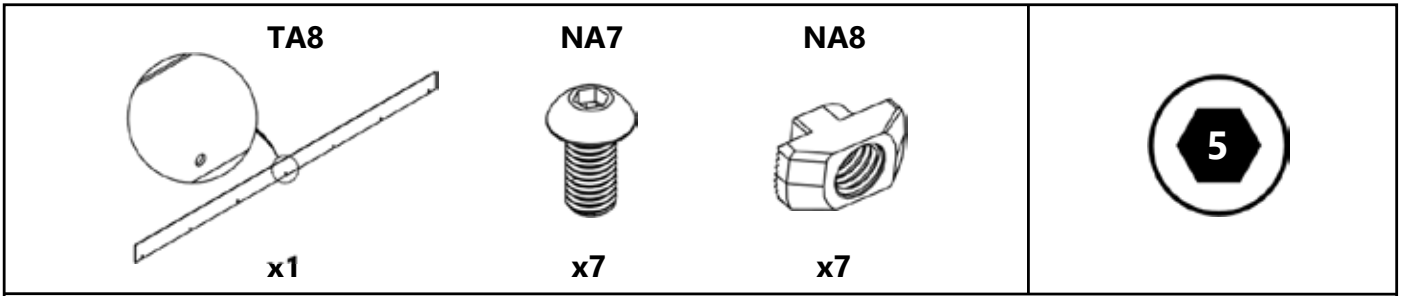

B.44
TBA.21

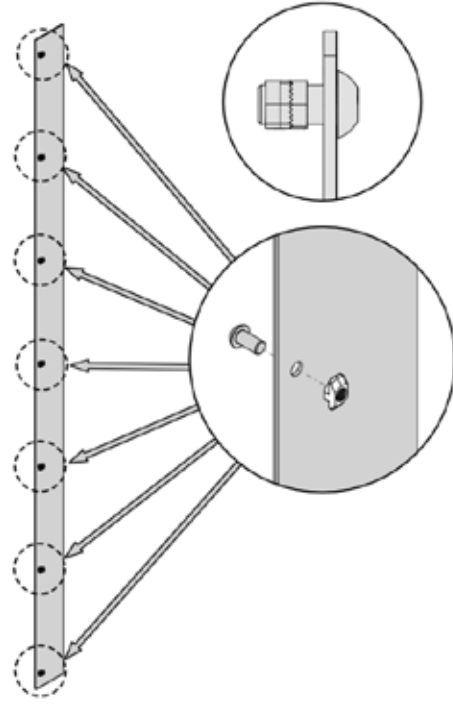



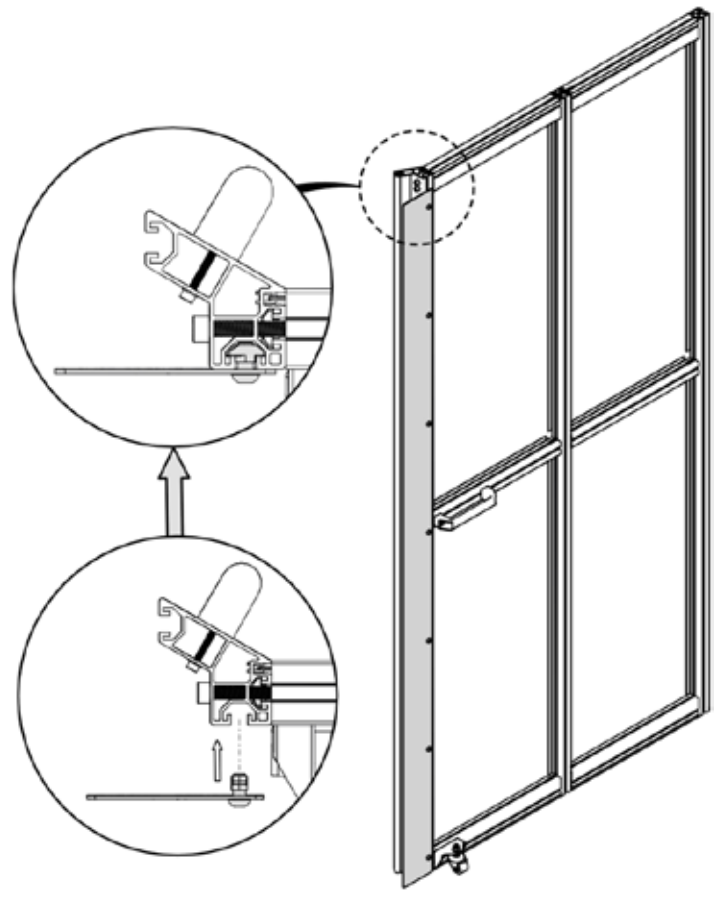

















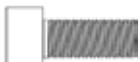









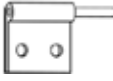



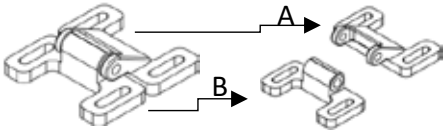

B.45
TBA.22



TÜR MIT FENSTER
DOOR WITH WINDOW



ART. NR.	OVERVIEW	NAME	QTY	ERP (anodized black)
TB1		B-Profil / B-profile 475	4	00005323 (00005324)
TB2		C-Profil / C-profile 475	4	00005328 (00005329)
TB3		C-Profil / C-profile 2250	1	00004153 (005332)
TB4		C-Profil mit Durchgangbohrungen/ C-profile with holes 2250	1	00004117 (00004549)
TB5		D-Profil mit Griffbohrungen/ D-profile with grip holes 2250	1	00005333 (00005334)
TB6		Platte / plate 1112x495x4	3	00005782
TB7		Haltblech für Lenkrolle/ Retaining plate for castor	1	00005339
TB8		Platte / plate 385x495x4	2	00005783
TB9		Laserschutzfenster/ laser protection window 495x300x5	1	00005703
NB1		Gewindeformverbinder/ Thread forming connector	24	00003998
NB2		Zylinderschraube gewindefurchend/ cap screw threaded DIN7500E M8x65	8	00003822
NB3		Unterlegescheibe / washer ISO 7089 - 8	6	00002796
NB4		Nutenstein / T-Slot Nut M8	2	00003789
NB5		Zylinderschraube / Socket head screw ISO 4726 M8x20	2	00002794

ART. NR.	OVERVIEW	NAME	QTY	ERP
NB6		Bügelgriff / handle	1	00002785
NB7		Schraube / screw ISO 7380 M8x16	26	00003962
NB8		Hamtermutter Nut / hammer nut 10 M8	26	00005357
NB9		Griff / handle	1	00003815
NB10		Unterlegescheibe / washer ISO 7089 - 4	2	00003880
NB11		Zylinderschraube / Socket head screw ISO 4726 M4x35	2	00003879
NB12		Scharnierprofil links / Hinge profile left	4	00003802
NB13		Scharnierprofil rechts / Hinge profile right	4	00003801
NB14		Scharnierprofil mitte / Hinge profile center	4	00004365
NB15		Unterlegescheibe / washer ISO 7089 - 6 Polyamid	8	00002954
NB16		Scheibe / Washer ISO 7089 - 10	2	00002953
NB17		Mutter / Hex nut ISO 4032 - M10	2	00003346
NB18		Lenkrolle / Castor	1	00005346
NB19		A. Türschnapper Gegenstück	1	00005422
		B. Türschnapper Kugelstück	1	
NB20		Zylinderschraube / Socket head screw ISO 4726 M6x20	4	00003792
NB21		Scheibe / Washer ISO 7089 - 6	4	91600366
NB22		Hamtermutter Nut / hammer nut 10 M6	4	00005415
NB23		Dichtungsprofil / Sealing profile		00004117
NB24		Fassungsprofil / Frame profile		00004119
NB25		Keilprofil / Wedge profile		00006041

B.46
TBB.1

 **B.24-36 / TBA.1-12**
gespiegelt / mirrored

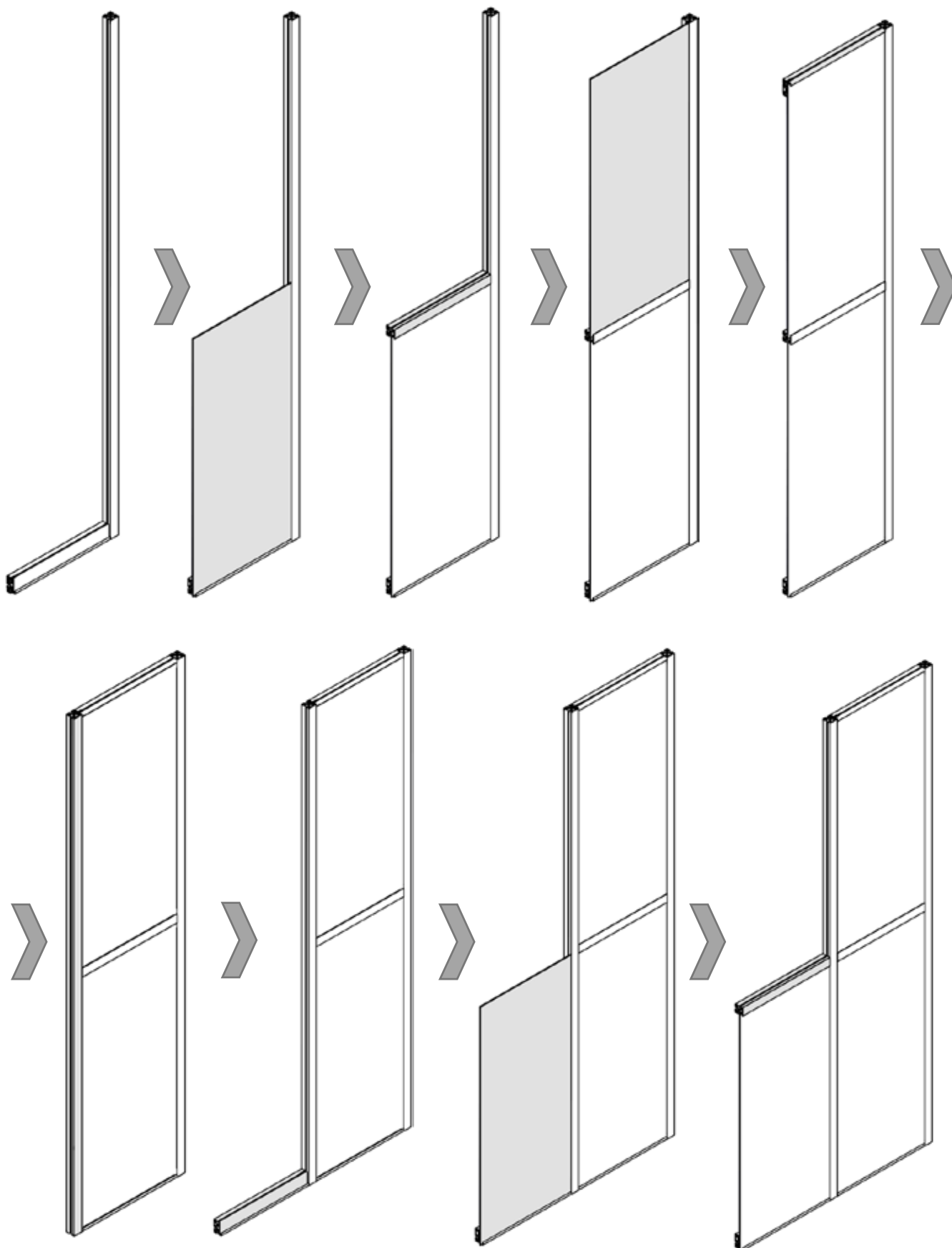

B.47

TBB.2

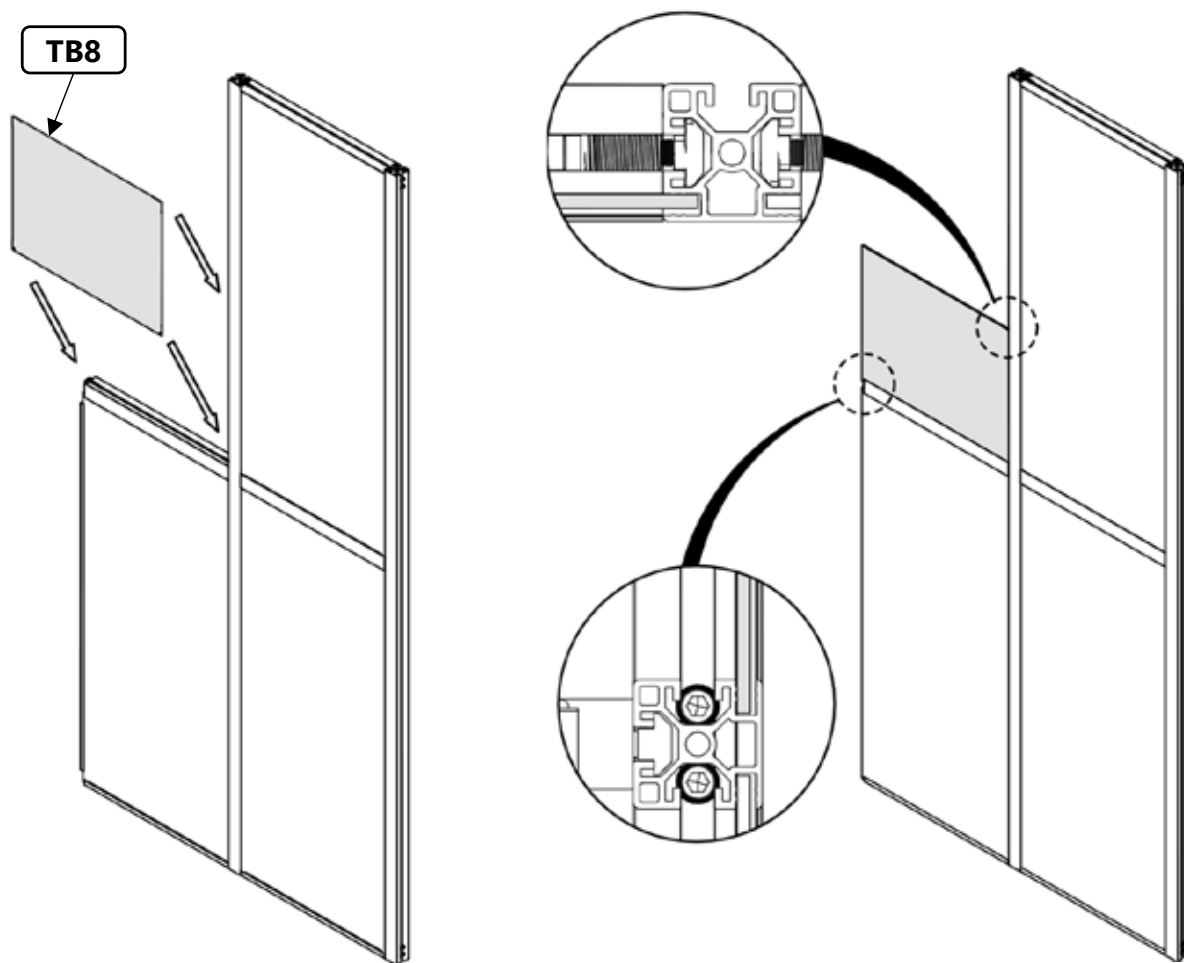

B.48

TBB.3

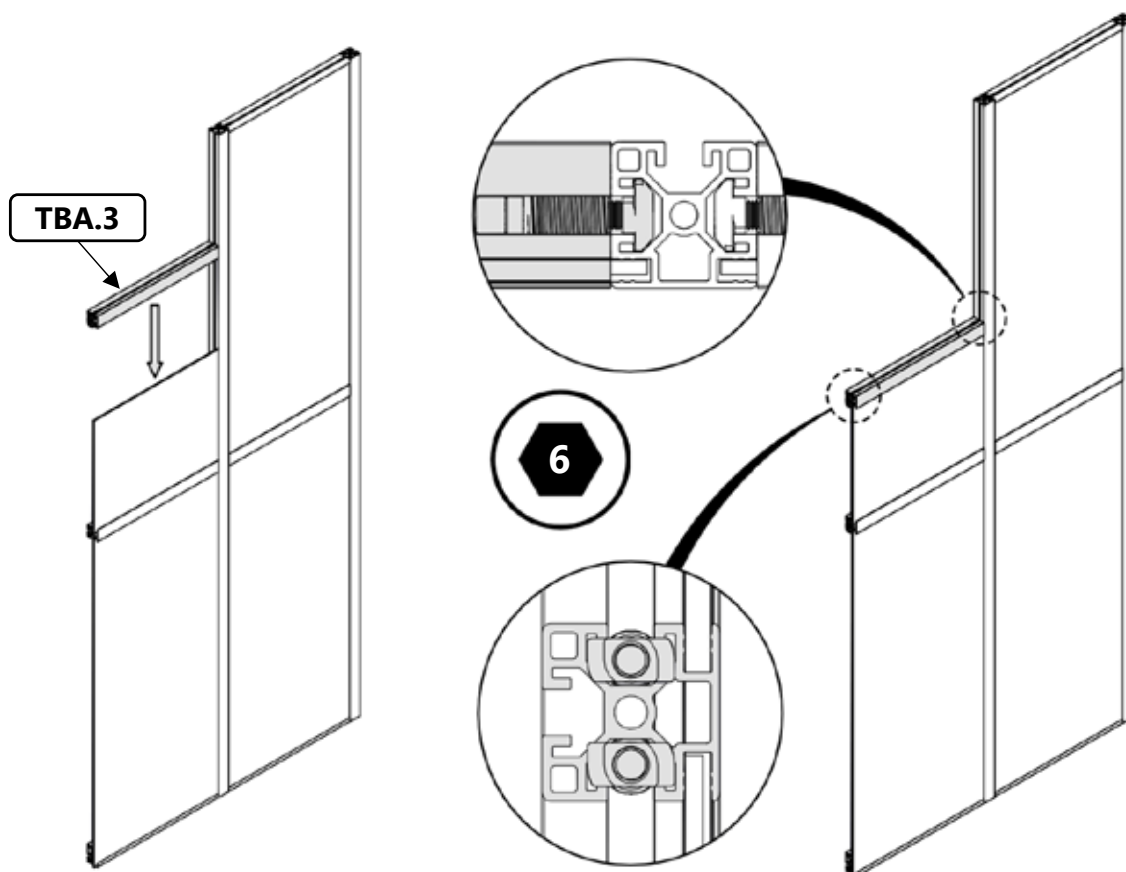

B.49

TBB.4

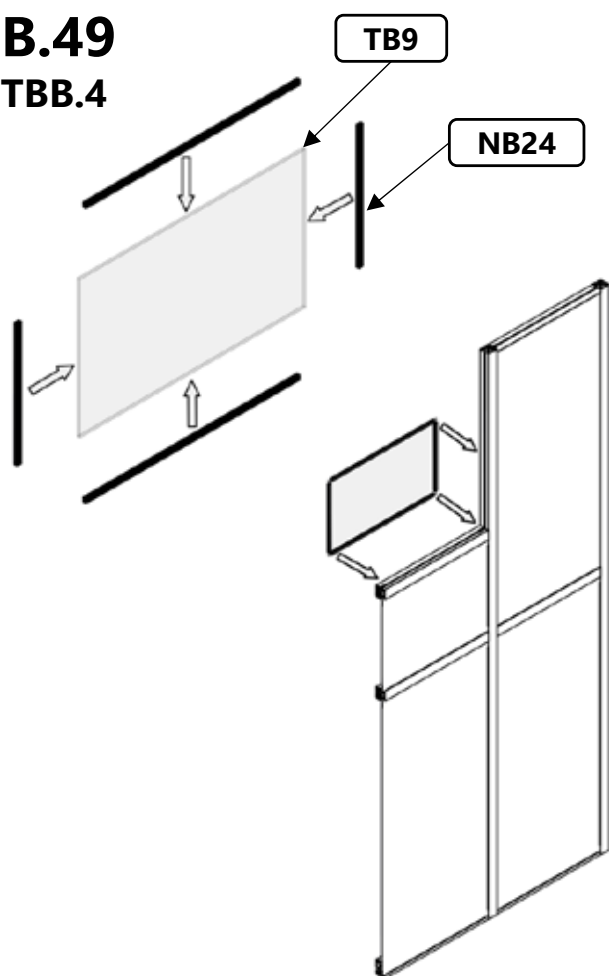

**Beschriftung außen/
Labeling outside**

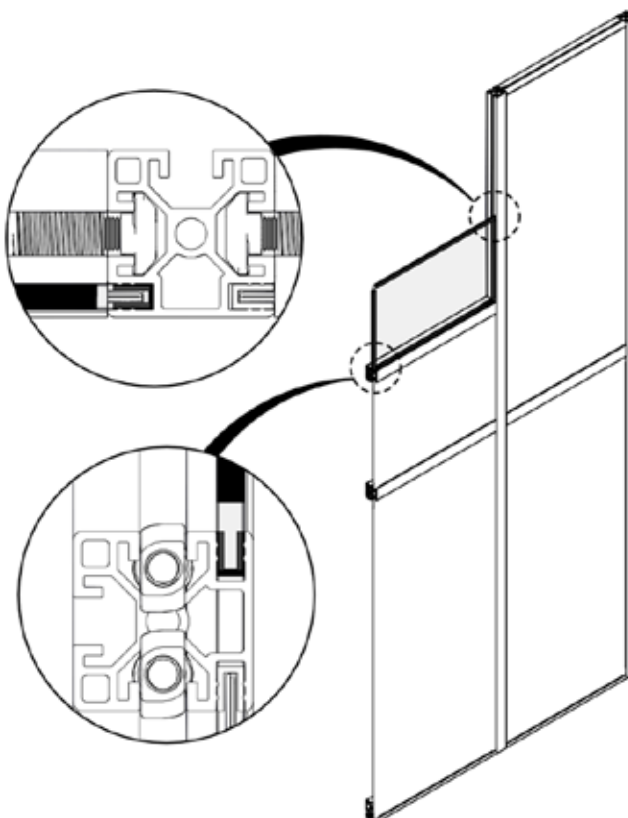

B.50
TBB.5

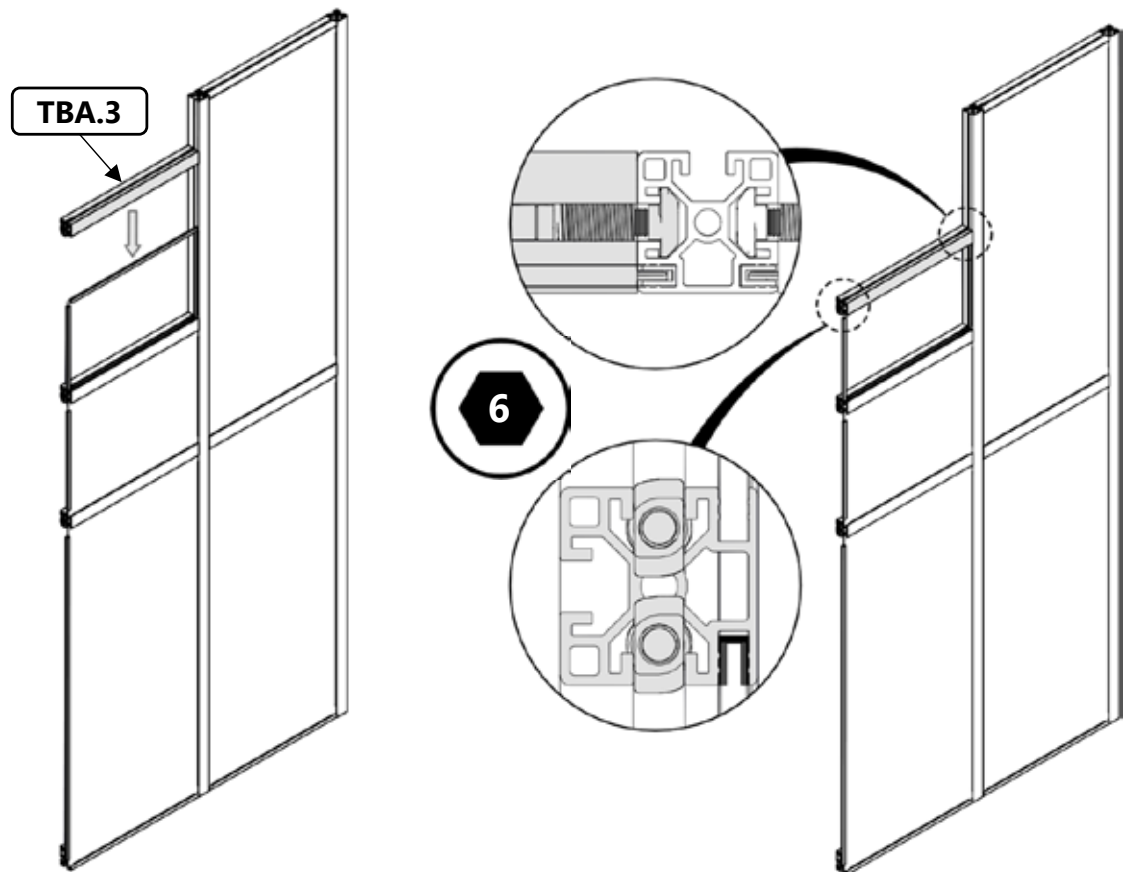

B.51
TBB.6

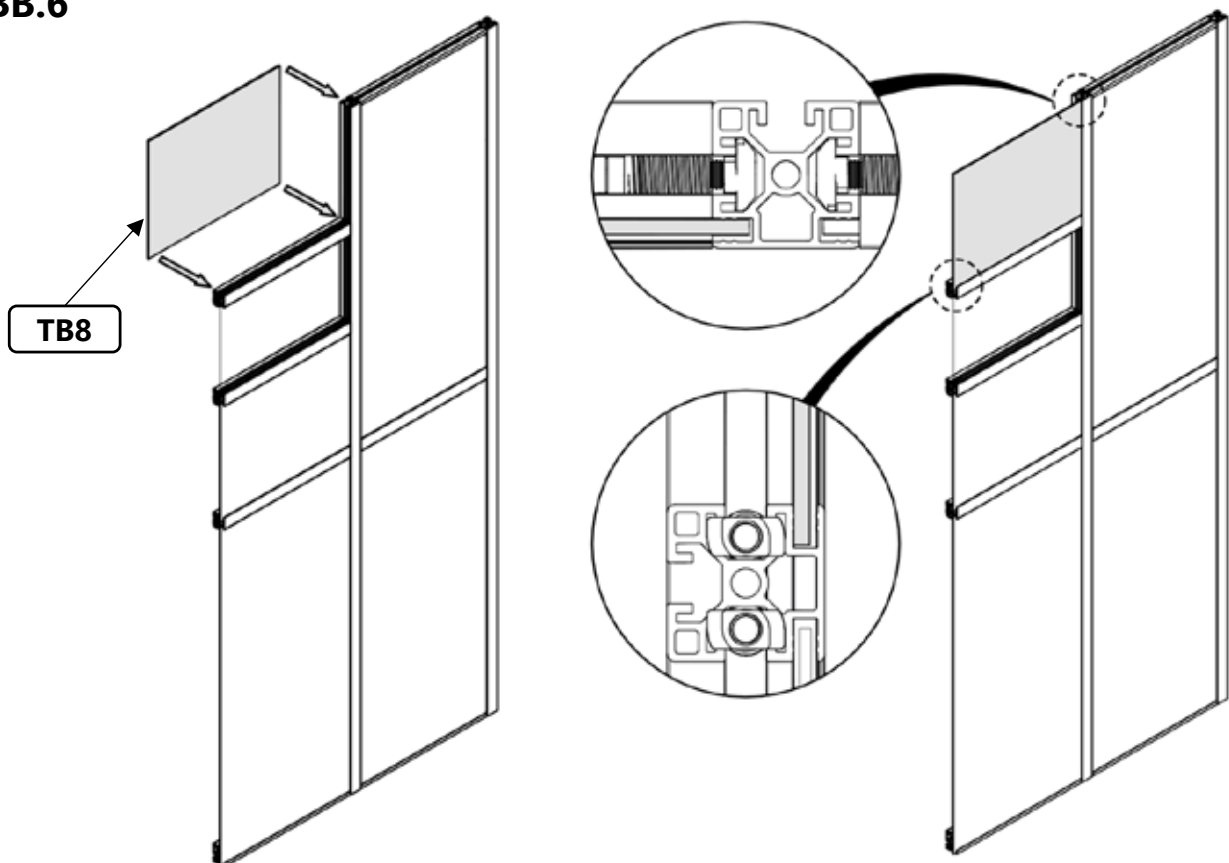

B.52
TBB.7

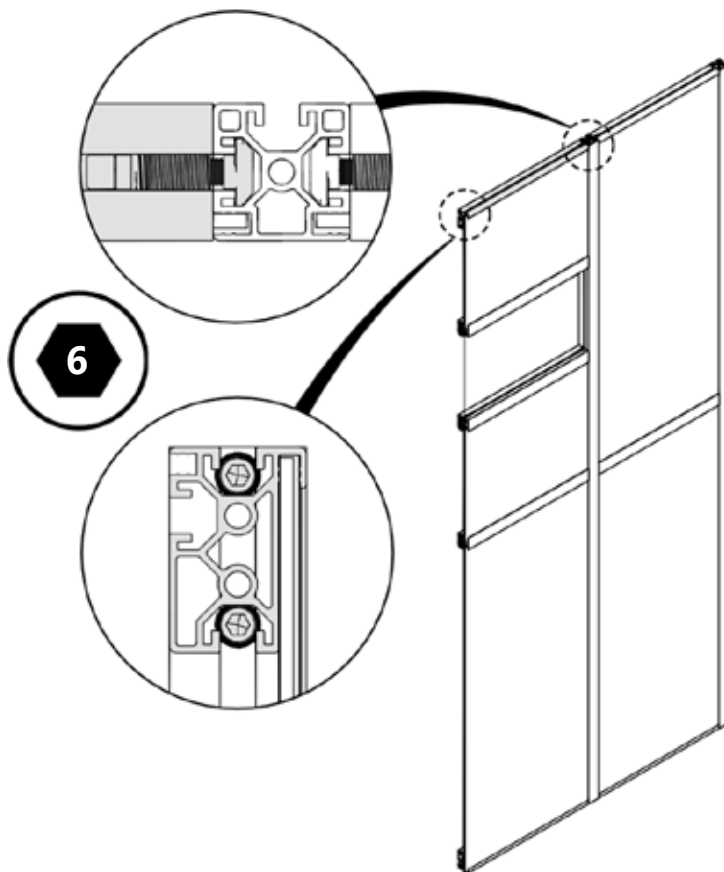
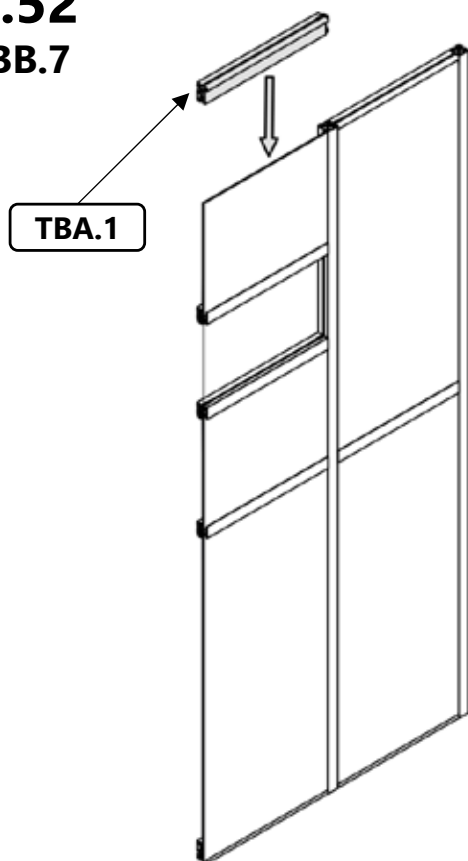

B.53
TBB.8

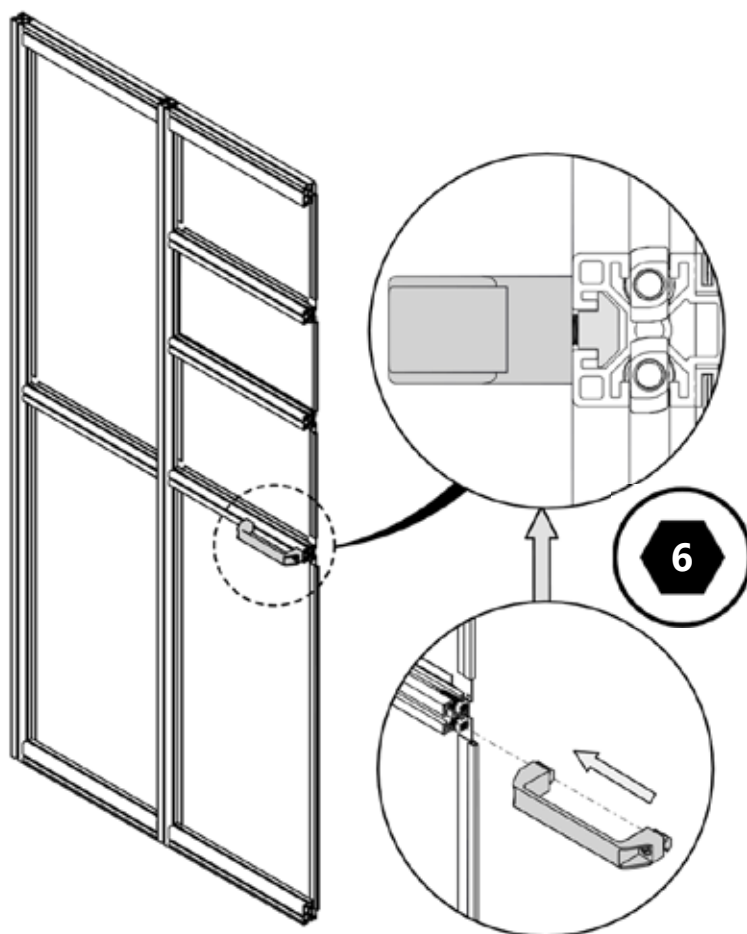
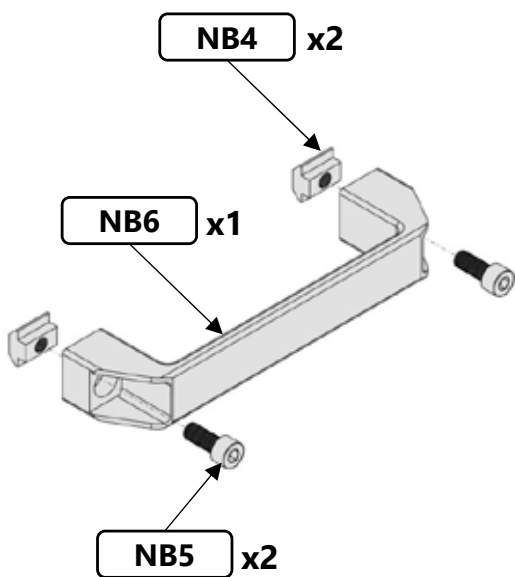

B.54

TBB.9



B.39
TBA.16

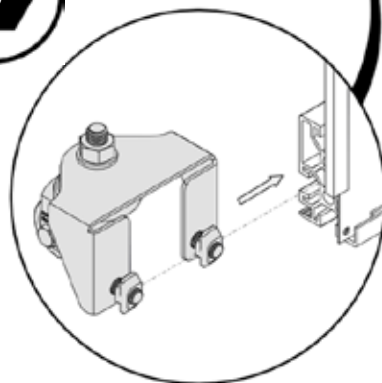
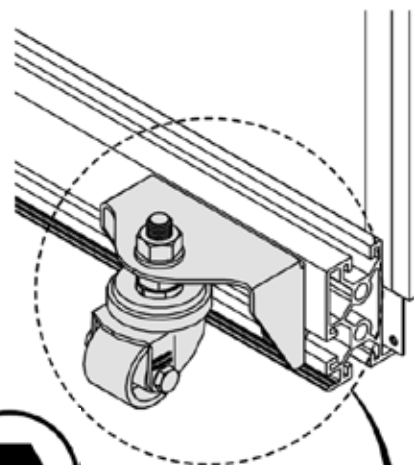
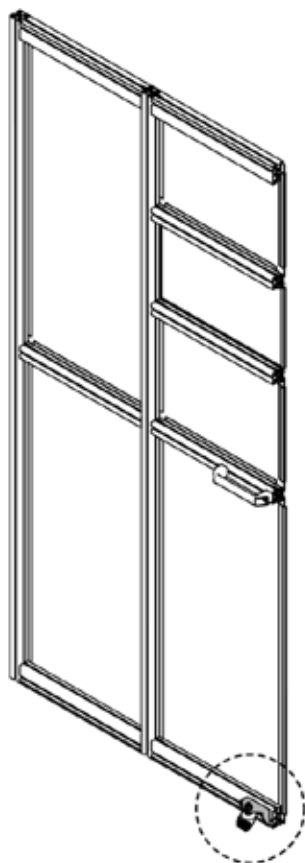
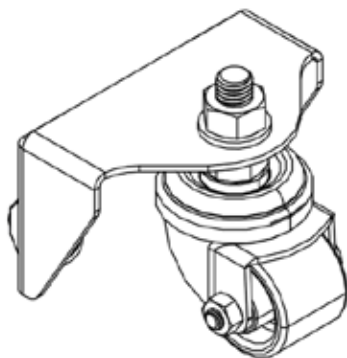







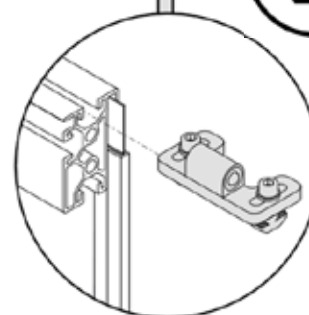
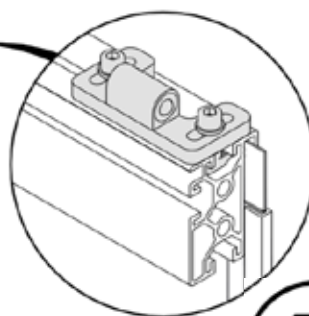
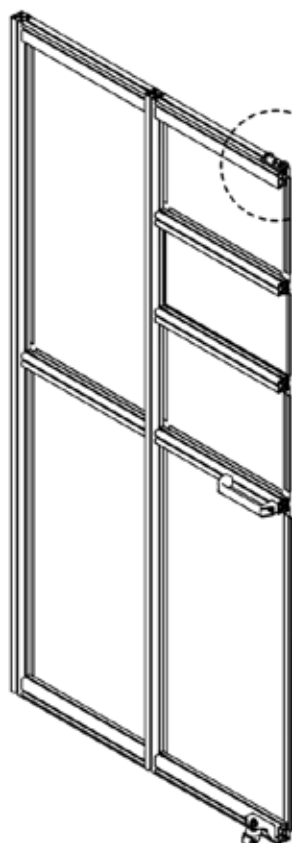
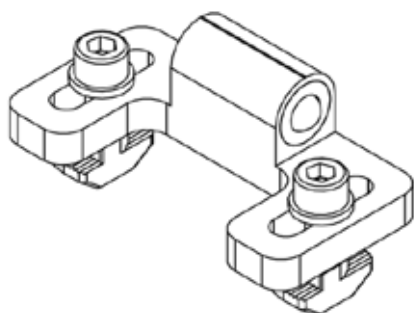

B.55

TBB.10



B.40
TBA.17



NB2  x4	NB3  x4	NB9  x1	NB10  x2	NB11  x2	 
---	---	---	--	--	---

B.56
TBB.11

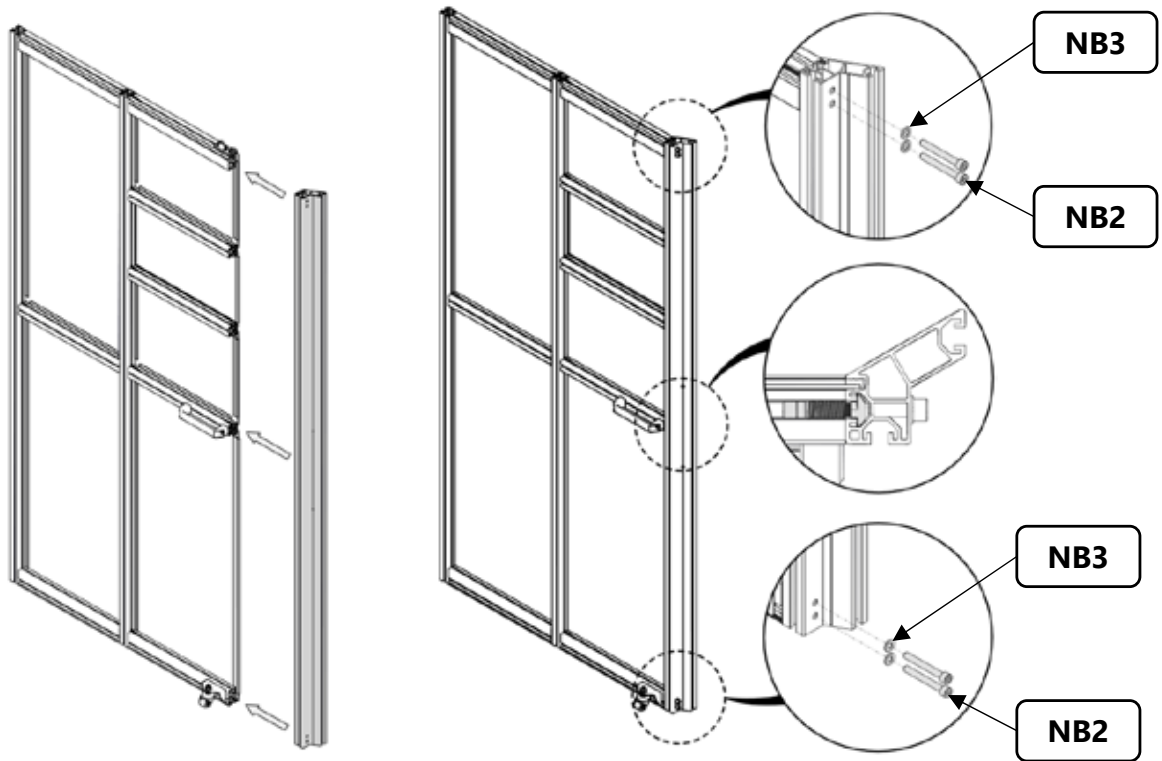

B.57
TBB.12

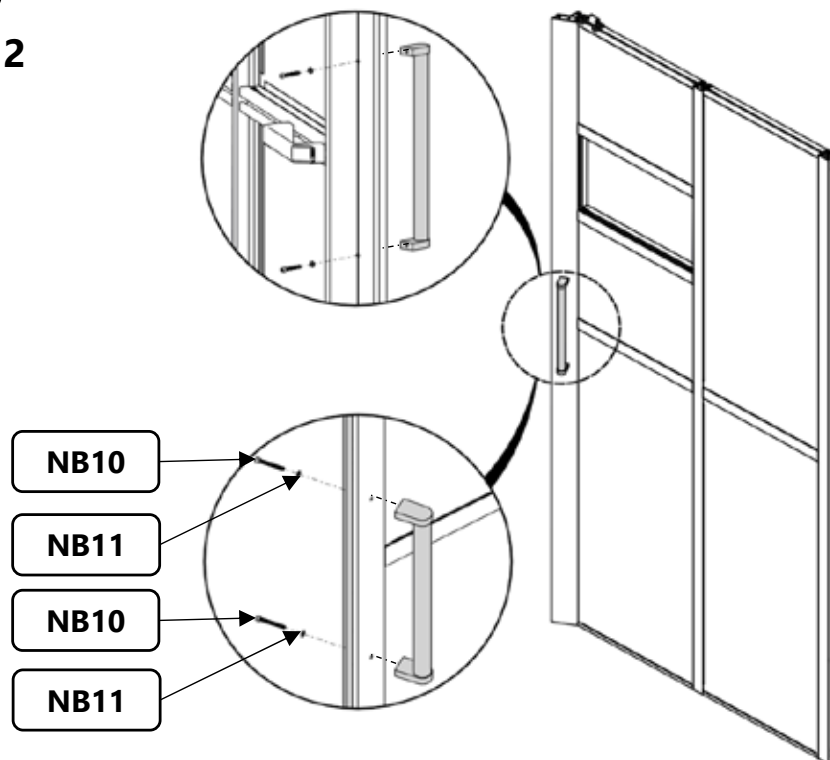





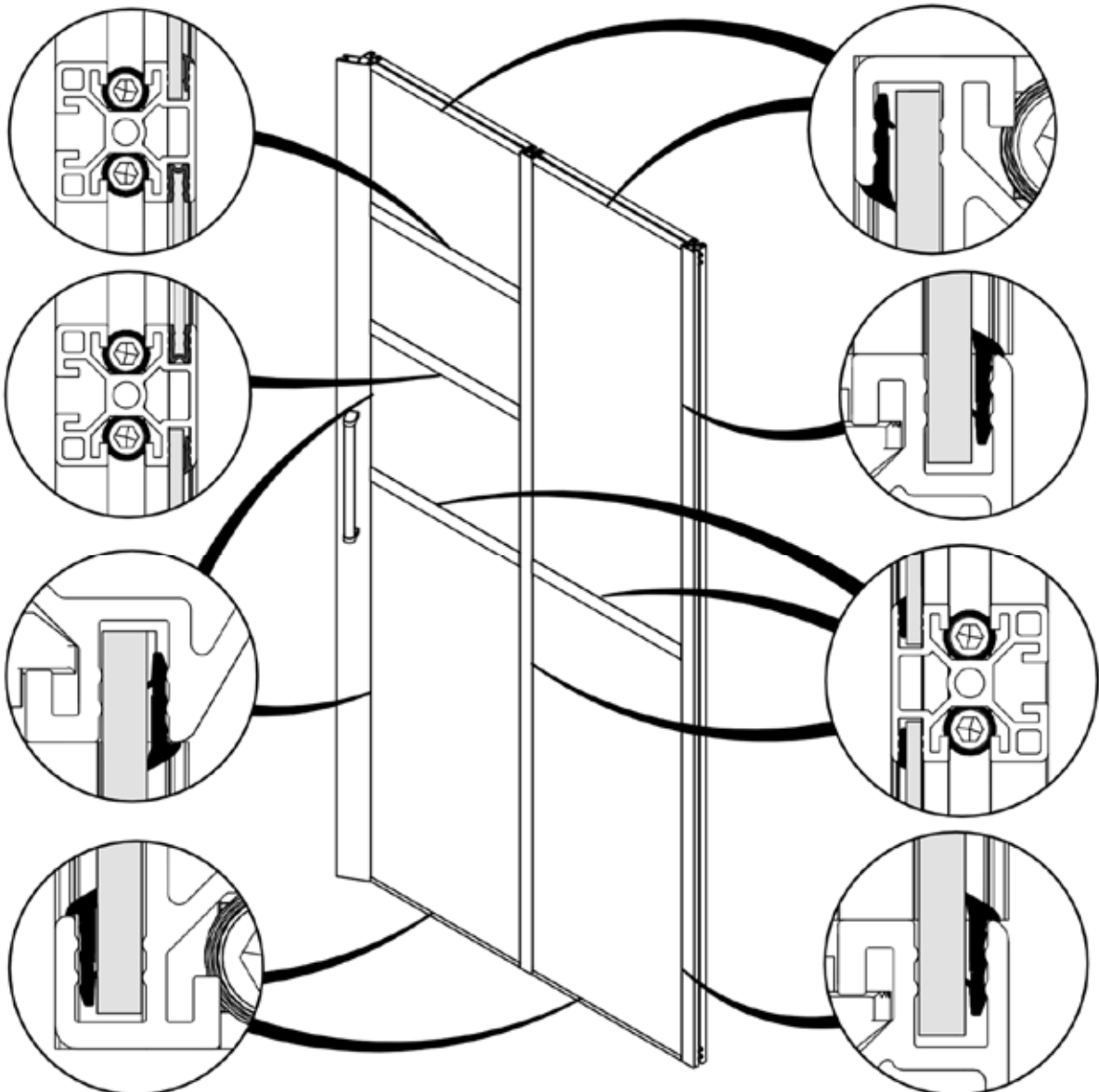
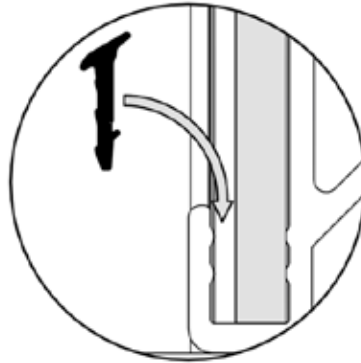

NB25



B.58
TBB.13



NA7 NB7  x24/24	NA8 NB8  x24/24	NA12 NB12  x4/4	NA14/NB14  x4/4	NA13 NB13  x4/4	NA15 NB15  x8/8	
---	---	---	---	---	--	---

B.59
TBA.23
TBB.14

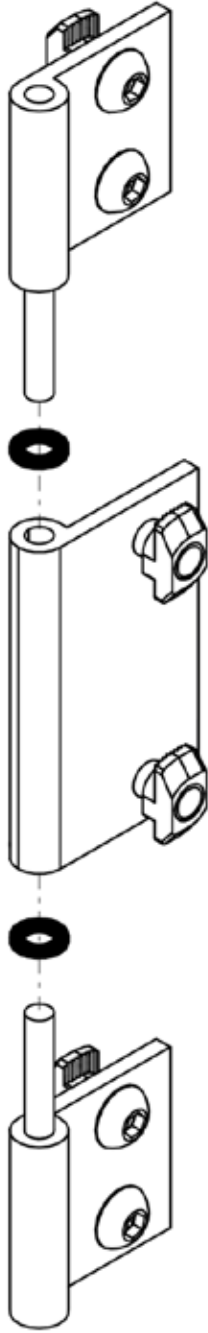
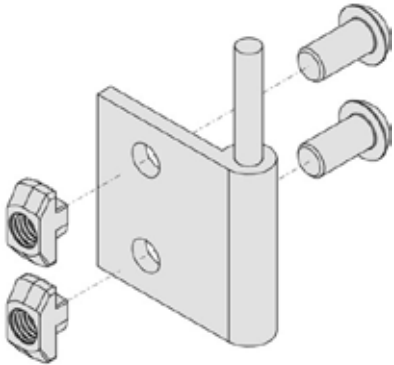
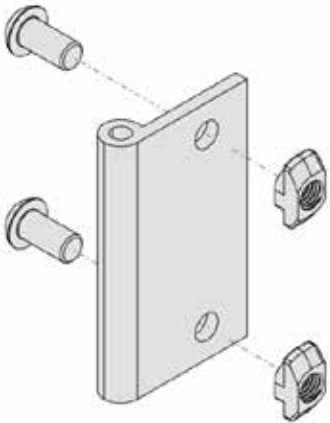
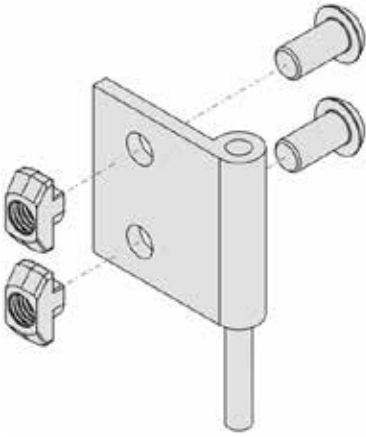

x4/4

Tür ohne Fenster/
Tür mit Fenster

Door without window/
Door with window

B.60
TBA.24
TBB.15

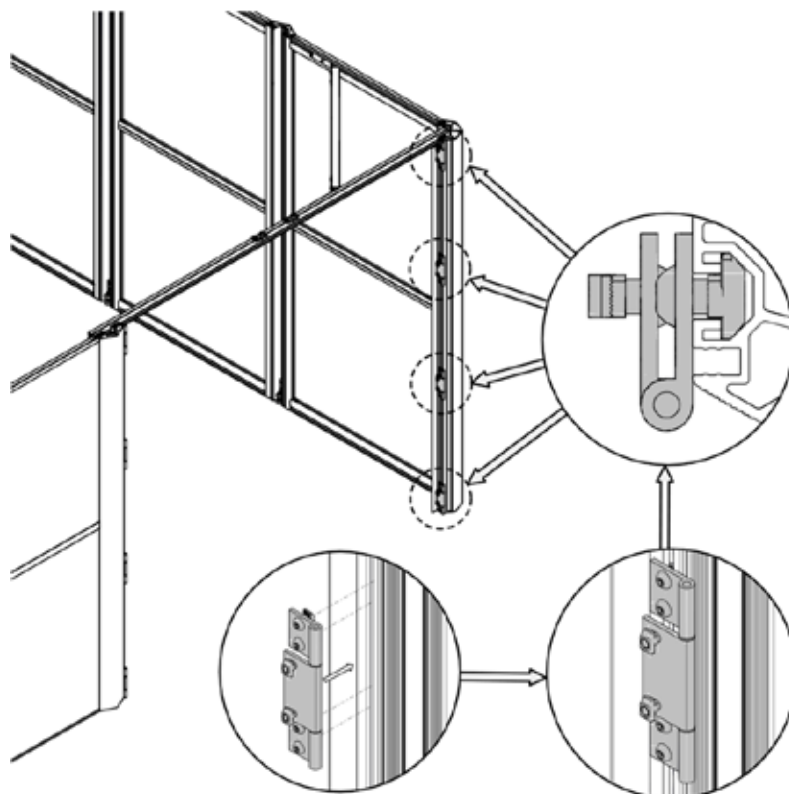
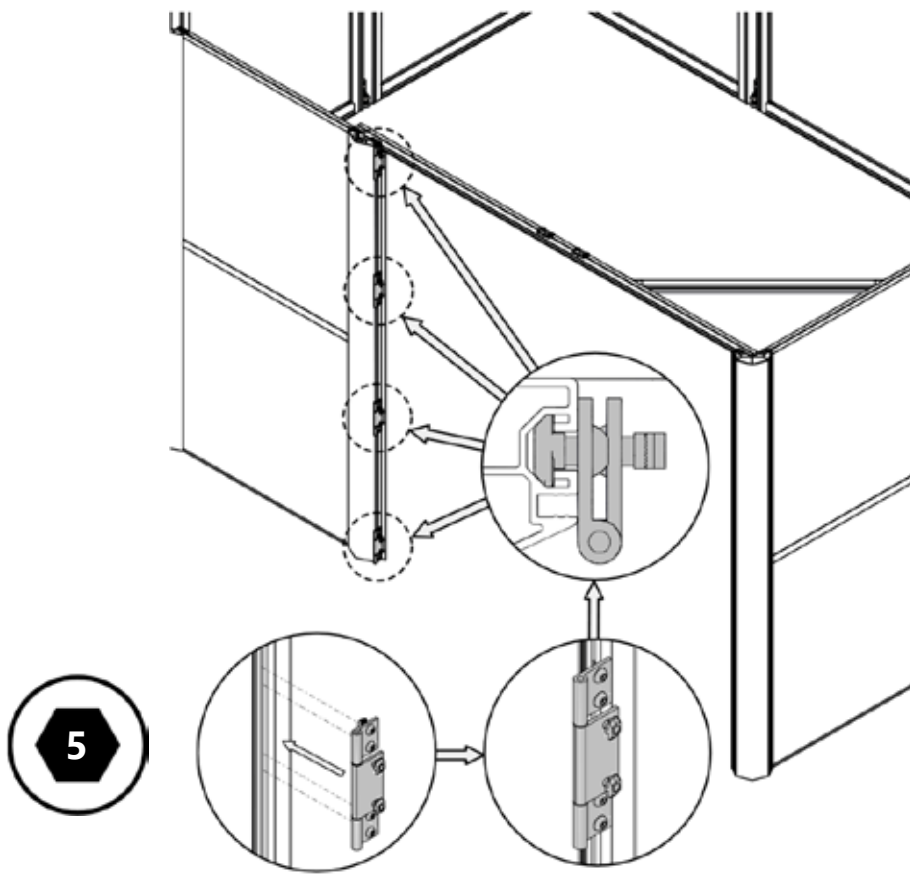

B.61

TBA.25

TBB.16

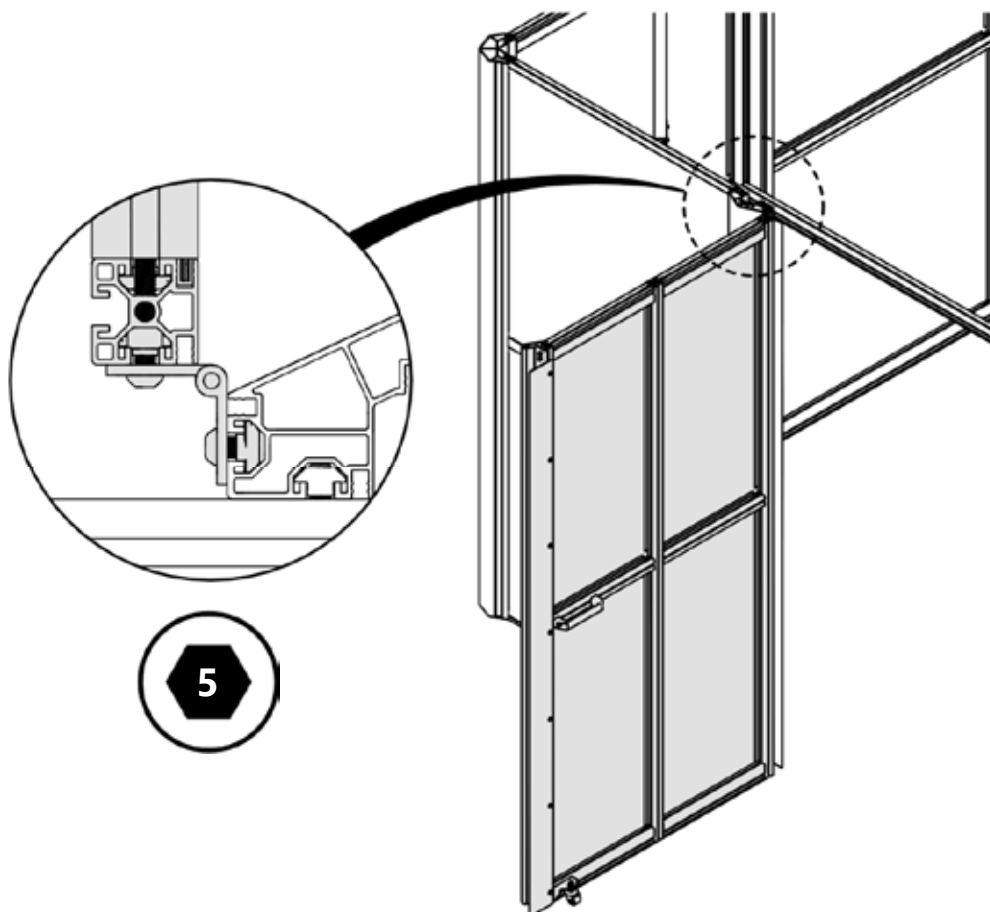
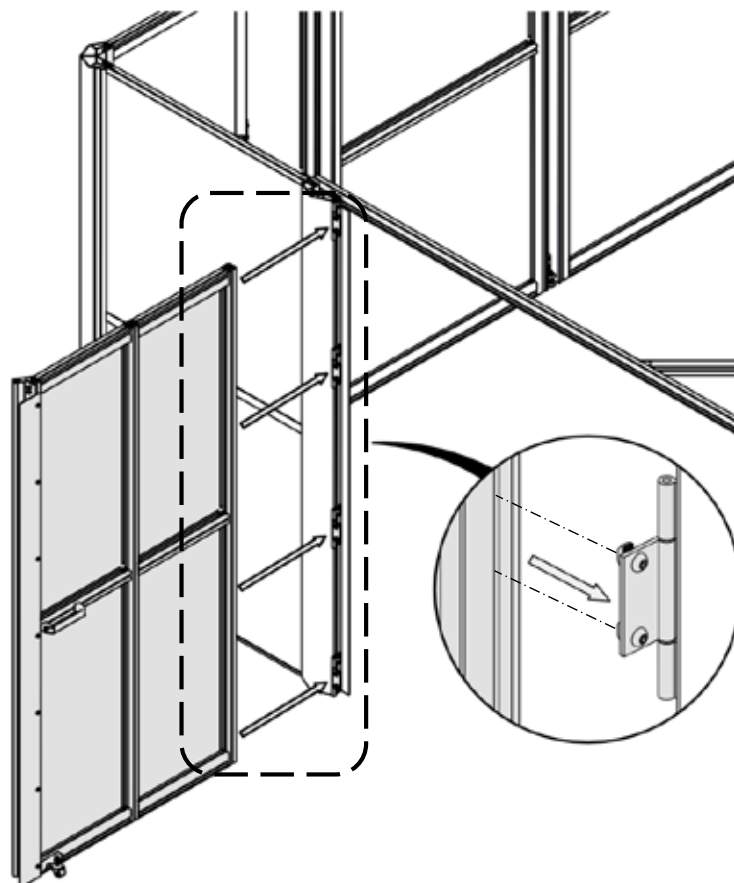

B.62
TBA.26
TBB.17

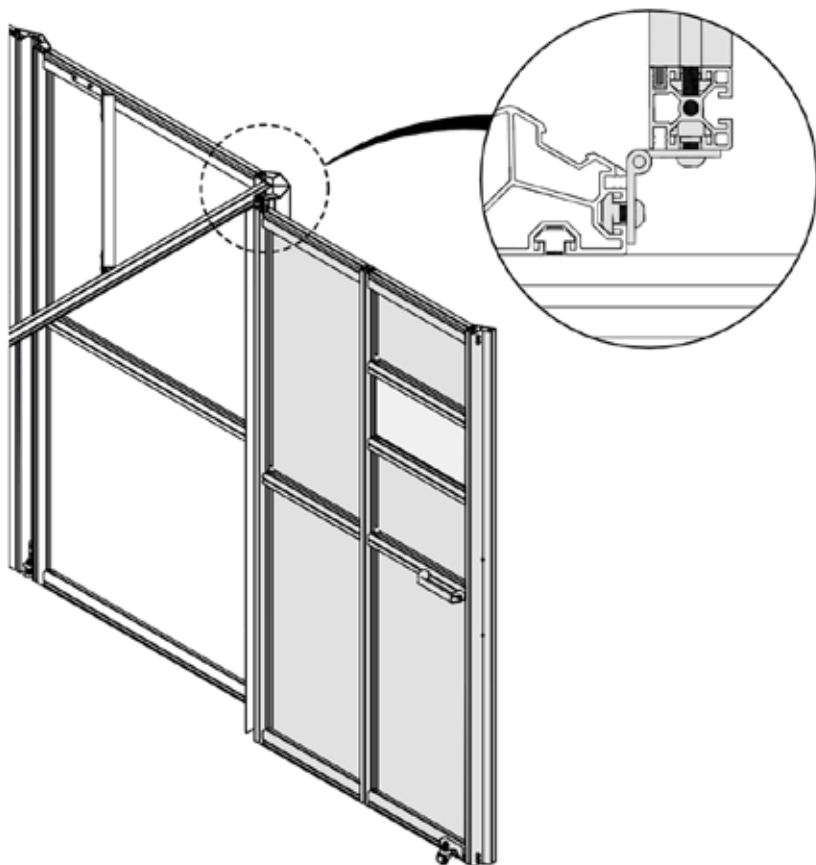
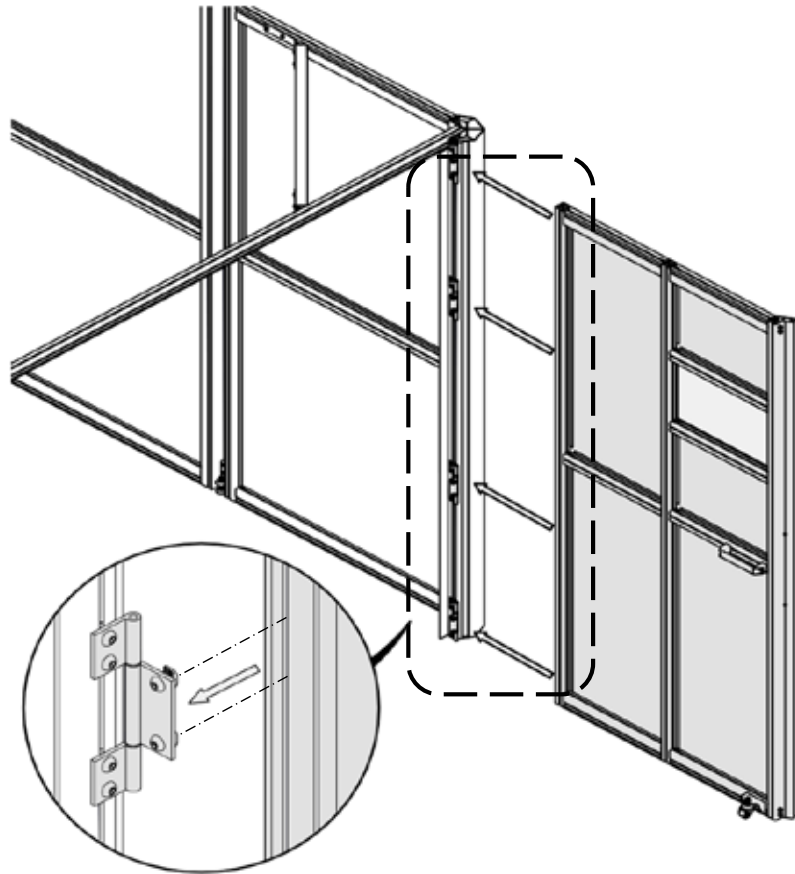

NA19.A
NB19.A

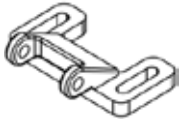

x2

NA20
NB20



x4

NA21
NB21



x4

NA22
NB22



x4



B.63
TBA.27
TBB.18

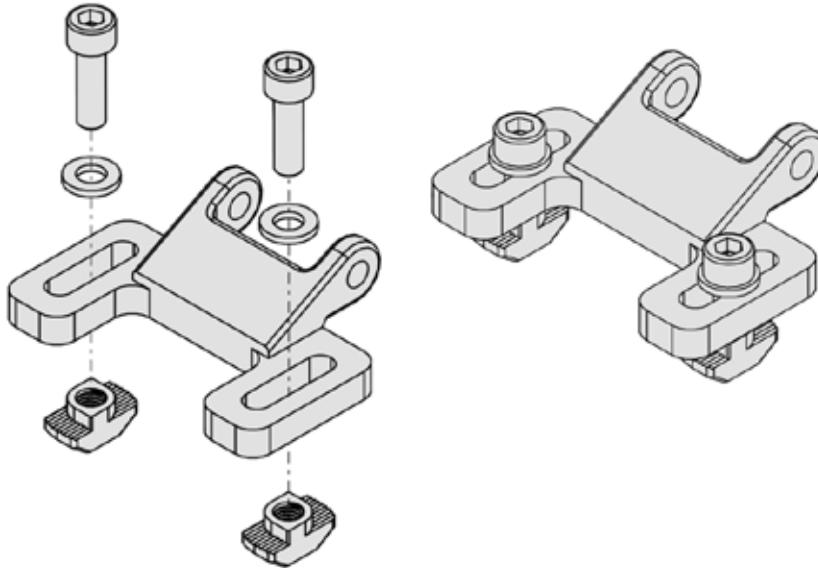

x2

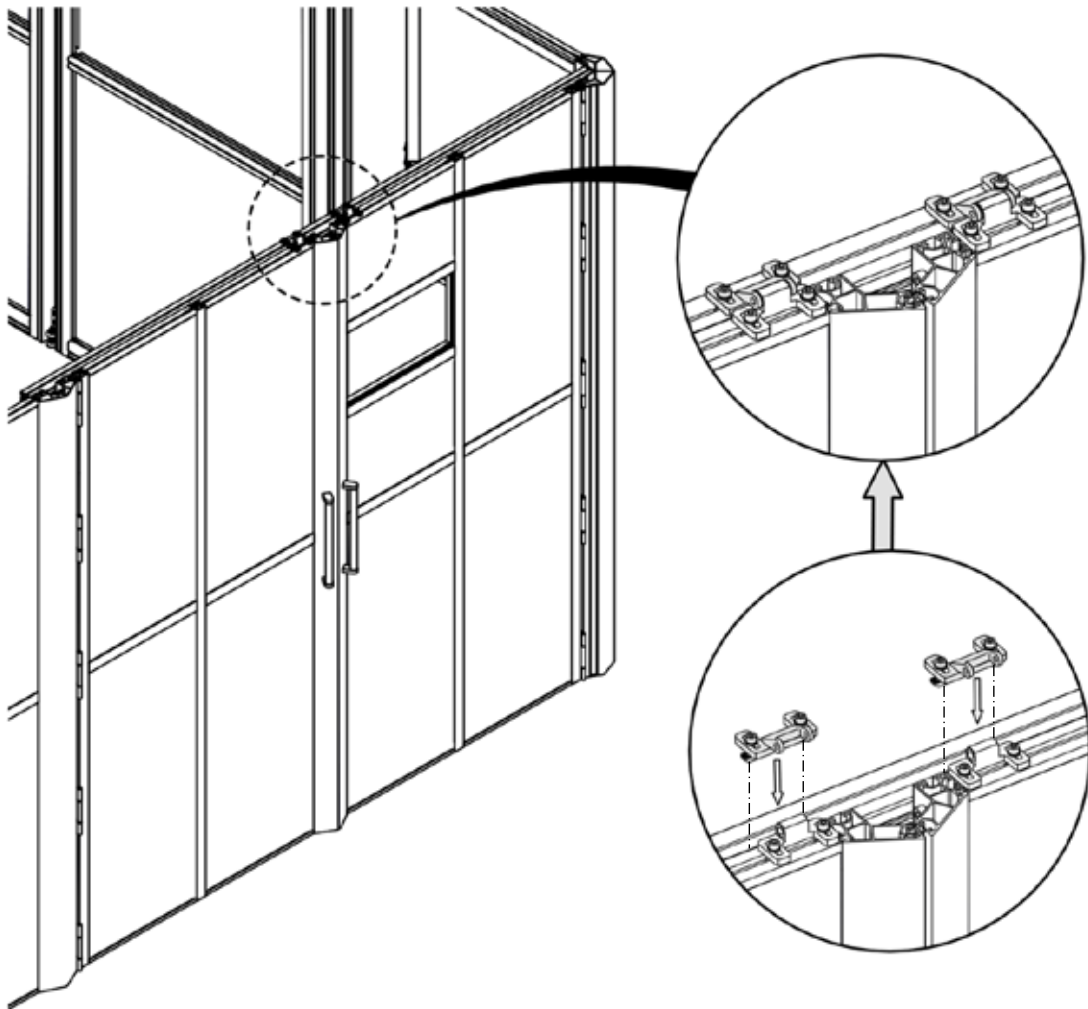



T9

B.64

LED-Beleuchtung / LED - lighting

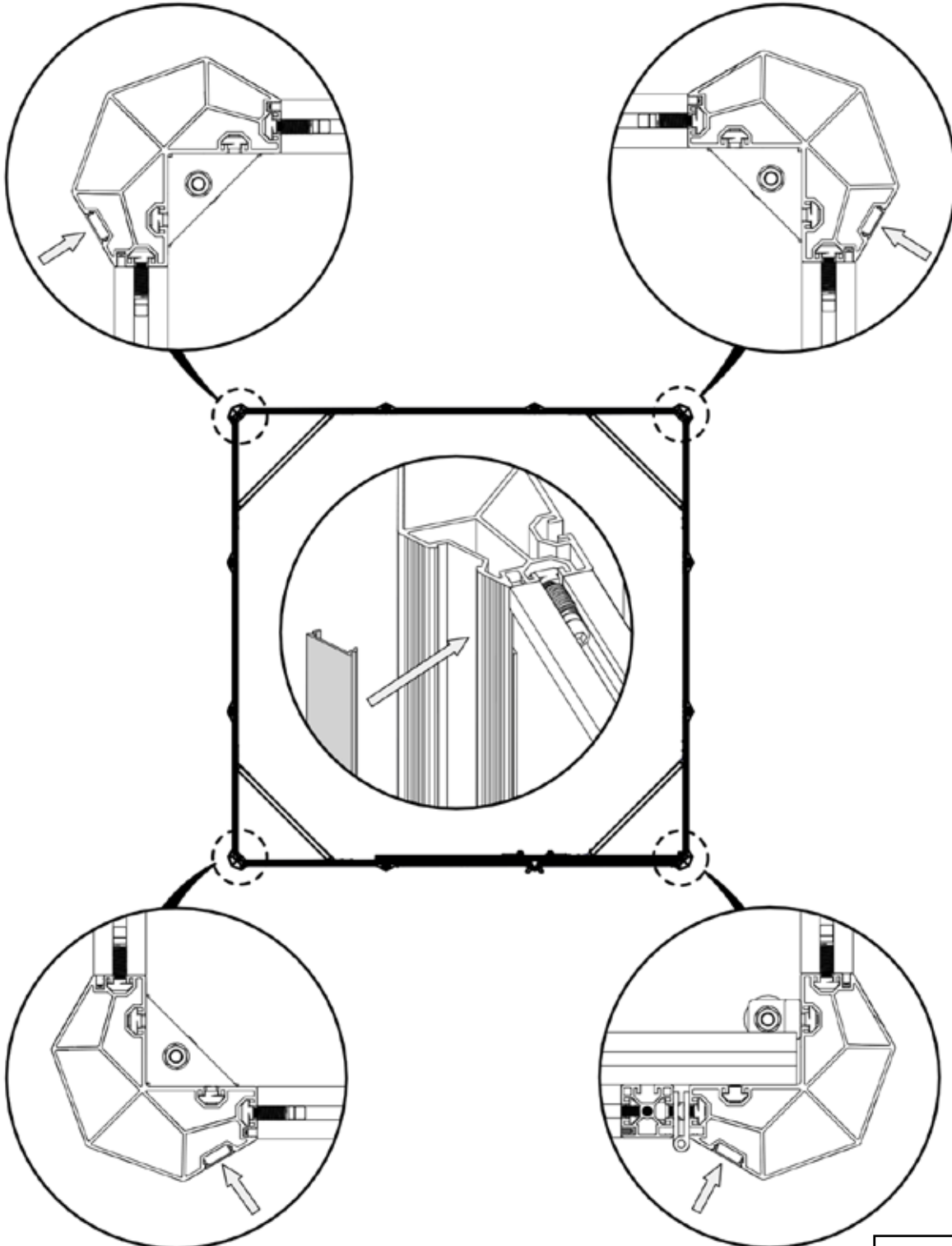

00005694 V1.4

